

**CBSE Board
Class XII Mathematics
Board Paper 2009
Delhi Set - 2**

Time: 3 hrs

Total Marks: 100

General Instructions:

1. All questions are compulsory.
2. The question paper consists of 29 questions divided into three Section A, B and C. Section A comprises of 10 questions of one mark each, Section B comprises of 12 questions of four marks each and Section C comprises of 7 questions of six marks each.
3. All questions in section A are to be answered in one word, one sentence or as per the exact requirement of the question.
4. There is no overall choice. However, internal choice has been provided in 4 questions of four marks each and 2 questions of six marks each. You have to attempt only one of the alternatives in all such questions.
5. Use of calculators is not permitted. You may ask for logarithmic tables, if required

SECTION - A

1. Using principal value, evaluate the following: $\sin^{-1}\left(\sin\frac{3\pi}{5}\right)$
2. Evaluate: $\int \sec^2(7-x) dx$
3. If $\int_0^1 (3x^2 + 2x + k) dx = 0$, find the value of k.
4. If the binary operation * on the set of integers Z, is defined by $a * b = a + 3b^2$, then find the value of $2 * 4$.
5. If A is an invertible matrix of order 3 and $|A| = 5$, then find $|\text{adj. } A|$.
6. Find the projection of \vec{a} on \vec{b} if $\vec{a} \cdot \vec{b} = 8$ and $\vec{b} = 2\hat{i} + 6\hat{j} + 3\hat{k}$
7. Write a unit vector in the direction of $\vec{b} = 2\hat{i} + \hat{j} + 2\hat{k}$.
8. Write the value of p for which $\vec{a} = 3\hat{i} + 2\hat{j} + 9\hat{k}$ and $\vec{b} = \hat{i} + p\hat{j} + 3\hat{k}$ are parallel vectors.
9. If matrix $A = (1, 2, 3)$, write AA' , where A' is the transpose of matrix A.

10. Write the value of the determinant $\begin{vmatrix} 2 & 3 & 4 \\ 5 & 6 & 8 \\ 6x & 9x & 12x \end{vmatrix}$

SECTION - B

11. Differentiate the following function w.r.t. x:

$$y = (\sin)^x + \sin^{-1}\sqrt{x}$$

12. Evaluate: $\int \frac{e^x}{\sqrt{5 - 4e^x - e^{2x}}} dx$.

OR

Evaluate: $\int \frac{(x-4)e^x}{(x-2)^3} dx$.

13. Prove that the relation R in the set $A = \{1, 2, 3, 4, 5\}$ given by $R = \{(a, b) : |a - b| \text{ is even}\}$, is an equivalence relation.

14. Find $\frac{dy}{dx}$ if $(x^2 + y^2)^2 = xy$.

OR

If $y = 3\cos(\log x) + 4\sin(\log x)$, then show that $x^2 \frac{d^2y}{dx^2} + x \frac{dy}{dx} + y = 0$

15. Find the equation of the tangent to the curve $y = \sqrt{3x-2}$ which is parallel to the line $4x - 2y + 5 = 0$

OR

Find the intervals in which the function f given by $f(x) = x^3 + \frac{1}{x^3}$, $x \neq 0$ is (i) increasing
(ii) decreasing.

16. If $\vec{a} \times \vec{b} = \vec{c} \times \vec{d}$ and $\vec{a} \times \vec{c} = \vec{b} \times \vec{d}$, show that $\vec{a} - \vec{d}$ is parallel to $\vec{b} - \vec{c}$, where $\vec{a} \neq \vec{d}$ and $\vec{b} \neq \vec{c}$

17. Prove that: $\sin^{-1}\left(\frac{4}{5}\right) + \sin^{-1}\left(\frac{5}{13}\right) + \sin^{-1}\left(\frac{16}{65}\right) = \frac{\pi}{2}$

OR

Solve for x: $\tan^{-1} 3x + \tan^{-1} 2x = \frac{\pi}{4}$

18. Find the value of λ so that the lines,

$$\frac{1-x}{3} = \frac{y-2}{2\lambda} = \frac{z-3}{2} \text{ and } \frac{x-1}{3\lambda} = \frac{y-1}{1} = \frac{6-z}{7} \text{ are perpendicular to each other.}$$

19. Solve the following differential equation:

$$(1+x^2) \frac{dy}{dx} + y = \tan^{-1} x$$

20. Find the particular solution, satisfying the given condition, for the following differential equation:

$$\frac{dy}{dx} - \frac{y}{x} + \operatorname{cosec}\left(\frac{y}{x}\right) = 0; y = 0 \text{ when } x = 1$$

21. Using properties of determinants prove the following:

$$\begin{vmatrix} a & b & c \\ a-b & b-c & c-a \\ b+c & c+a & a+b \end{vmatrix} = a^3 + b^3 + c^3 - 3abc$$

22. A die is thrown again and again until three sixes are obtained. Find the probability of obtaining the third six in the sixth throw of the die.

SECTION - C

23. Two groups are competing for the position on the Board of Directors of a corporation. The probabilities that the first and the second groups will win are 0.6 and 0.4 respectively. Further, if the first group wins, the probability of introducing a new product is 0.7 and the corresponding probability is 0.3 if the second group wins. Find the probability that the new product was introduced by the second group.

24. Using matrices, solve the following system of equations:

$$2x - 3y + 5 = 11$$

$$3x + 2y - 4z = -5$$

$$x + y - 2z = -3$$

25. Evaluate: $\int_0^{\pi} \frac{e^{\cos x}}{e^{\cos x} + e^{-\cos x}} dx$

OR

Evaluate: $\int_0^{\frac{\pi}{2}} (2 \log \sin x - \log \sin 2x) dx$

26. Prove that the curves $y^2 = 4x$ and $x^2 = 4y$ divide the area of the square bounded by $x = 0$, $x = 4$, $y = 4$, and $y = 0$ into three equal parts.
27. Find the equation of the plane passing through the point $(-1, 3, 2)$ and perpendicular to each of the planes $x + 2y + 3z = 5$ and $3x + 3y + z = 0$.
28. Find the volume of the largest cylinder that can be inscribed in a sphere of radius r .

OR

A tank with rectangular base and rectangular sides, open at the top is to be constructed so that its depth is 2 m and volume is 8 m^3 . If building of tank costs Rs. 70 per square metre for the base and Rs. 45 per square metre for sides, what is the cost of least expensive tank?

29. A diet is to contain at least 80 units of Vitamin A and 100 units of minerals. Two foods F_1 and F_2 are available. Food F_1 cost Rs. 4 per unit and F_2 costs Rs. 6 per unit. One unit of food F_1 contains 3 units of Vitamin A and 4 units of minerals. One unit of food F_2 contains 6 units of Vitamin A and 3 units of minerals. Formulate this as a linear programming problem and find graphically the minimum cost for diet that consists of mixture of these two foods and also meets the minerals nutritional requirements.

**CBSE Board
Class XII Mathematics
Board Paper 2009 Solution
Delhi Set - 2**

SECTION - A

1. As $\sin^{-1}(\sin\theta) = \theta$ so $\sin^{-1}\left(\sin\left(\frac{3\pi}{5}\right)\right) = \frac{3\pi}{5}$

But $\frac{3\pi}{5} \notin \left[-\frac{\pi}{2}, \frac{\pi}{2}\right]$

So

$$\sin^{-1}\left(\sin\left(\frac{3\pi}{5}\right)\right) = \sin^{-1}\left(\sin\left(\pi - \frac{2\pi}{5}\right)\right)$$

$$= \sin^{-1}\left(\sin\frac{2\pi}{5}\right)$$

$$= \frac{2\pi}{5} \in \left[-\frac{\pi}{2}, \frac{\pi}{2}\right]$$

\therefore Principal value is $\frac{2\pi}{5}$

2. $I = \int \sec^2(7-x).dx$

Substituting $7-x = t \Rightarrow -dx = dt$

$$\therefore I = -\int \sec^2 t .dt$$

$$= -\tan(7-x) + c$$

3. Given: $\int_0^1 (3x^2 + 2x + k)dx = 0$

$$\Rightarrow \left[\frac{3x^3}{3} + \frac{2x^2}{2} + kx \right]_0^1 = 0$$

$$\Rightarrow \left[x^3 + x^2 + kx \right]_0^1 = 0$$

$$\Rightarrow [1 + 1 + k] = 0$$

$$\Rightarrow k = -2$$

4.

$$\text{Given } a * b = a + 3b^2 \quad \forall a, b \in \mathbb{Z}$$

$$\text{Therefore, } 2 * 4 = 2 + 3 \times 4^2 = 50$$

5.

$$|\text{adj}A| = |A|^{n-1}, \text{ where } n \text{ is order of square matrix}$$

Given A is an invertible matrix of order 3

$$|\text{adj}A| = |A|^{3-1} = |A|^2$$

$$\text{Since, } |A| = 5$$

$$\therefore |\text{adj}A| = (5)^2 = 25$$

6. Projection of \vec{a} on \vec{b} is given by $\frac{\vec{a} \cdot \vec{b}}{|\vec{b}|}$ (i)

$$\text{Given } \vec{a} \cdot \vec{b} = 8 \text{ and } \vec{b} = 2\hat{i} + 6\hat{j} + 3\hat{k}$$

$$|\vec{b}| = \sqrt{4 + 36 + 9} = 7$$

Substituting value in (i) we get

$$\text{Projection of } \vec{a} \text{ on } \vec{b} = \frac{8}{7}$$

7. $\vec{b} = 2\hat{i} + \hat{j} + 2\hat{k}$

Unit vector in the direction of \vec{b} is given by $\frac{\vec{b}}{|\vec{b}|}$

$$\frac{\vec{b}}{|\vec{b}|} = \frac{2\hat{i} + \hat{j} + 2\hat{k}}{\sqrt{9}}$$

$$= \frac{1}{3} (2\hat{i} + \hat{j} + 2\hat{k})$$

8. Two vectors \vec{a} and \vec{b} are parallel

$$\vec{a} = 3\hat{i} + 2\hat{j} + 9\hat{k} \text{ and } \vec{b} = \hat{i} + p\hat{j} + 3\hat{k}$$

$$\vec{a} = \lambda\vec{b}$$

$$\text{So } 3\hat{i} + 2\hat{j} + 9\hat{k} = \lambda(\hat{i} + p\hat{j} + 3\hat{k})$$

$$\Rightarrow 3\hat{i} + 2\hat{j} + 9\hat{k} = \lambda\hat{i} + p\lambda\hat{j} + 3\lambda\hat{k}$$

$$\Rightarrow \lambda = 3, \quad p\lambda = 2 \text{ and } 9 = 3\lambda$$

$$\Rightarrow p = \frac{2}{3}$$

9. Given: $A = [1 \ 2 \ 3]$

$$\therefore A' = \begin{bmatrix} 1 \\ 2 \\ 3 \end{bmatrix}$$

$$AA' = [1 \ 2 \ 3] \begin{bmatrix} 1 \\ 2 \\ 3 \end{bmatrix} = [1 \times 1 + 2 \times 2 + 3 \times 3] \\ = [14]$$

10. $\Delta = \begin{vmatrix} 2 & 3 & 4 \\ 5 & 6 & 8 \\ 6x & 9x & 12x \end{vmatrix}$

$$R_3 \rightarrow \frac{1}{3x}R_3$$

$$\Delta = 3x \begin{vmatrix} 2 & 3 & 4 \\ 5 & 6 & 8 \\ 2 & 3 & 4 \end{vmatrix}$$

$$\text{Now, } R_1 = R_3$$

$$\therefore \Delta = 0$$

SECTION - B

11. $y = (\sin x)^x + \sin^{-1} \sqrt{x}$

Let $u = (\sin x)^x$ and $v = \sin^{-1} \sqrt{x}$

Now $y = u + v$

$$\frac{dy}{dx} = \frac{du}{dx} + \frac{dv}{dx} \text{---(i)}$$

Consider $u = (\sin x)^x$

Taking logarithms on both the sides, we have,

$$\log u = x \log(\sin x)$$

Differentiating with respect to x , we have,

$$\frac{1}{u} \cdot \frac{du}{dx} = \log(\sin x) + \frac{x}{\sin x} \cdot \cos x$$

$$\Rightarrow \frac{du}{dx} = (\sin x)^x (\log(\sin x) + x \cot x) \text{---(ii)}$$

Consider $v = \sin^{-1} \sqrt{x}$

$$\frac{dv}{dx} = \frac{1}{\sqrt{1-x}} \times \frac{1}{2\sqrt{x}} \text{---(iii)}$$

From (i), (ii) and (iii)

We get, $\frac{dy}{dx} = (\sin x)^x (\log(\sin x) + x \cot x) + \frac{1}{2\sqrt{x}\sqrt{1-x}}$

12. $I = \int \frac{e^x}{\sqrt{5-4e^x-e^{2x}}} dx$

Let $e^x = t$ $e^x dx = dt$

Now integral I becomes,

$$I = \int \frac{dt}{\sqrt{5-4t-t^2}}$$

$$\Rightarrow I = \int \frac{dt}{\sqrt{5+4-4-4t-t^2}}$$

$$\Rightarrow I = \int \frac{dt}{\sqrt{9-(4+4t+t^2)}}$$

$$\Rightarrow I = \int \frac{dt}{\sqrt{9-(t+2)^2}}$$

$$\Rightarrow I = \int \frac{dt}{\sqrt{3^2-(t+2)^2}}$$

$$\Rightarrow I = \sin^{-1} \frac{(t+2)}{3} + C$$

$$\Rightarrow I = \sin^{-1} \frac{(e^x+2)}{3} + C$$

OR

$$I = \int \frac{(x-4)e^x}{(x-2)^3} dx$$

$$I = \int e^x \left(\frac{x-2}{(x-2)^3} - \frac{2}{(x-2)^3} \right) dx$$

$$I = \int e^x \left(\frac{1}{(x-2)^2} - \frac{2}{(x-2)^3} \right) dx$$

Thus the given integral is of the form,

$$I = \int e^x |f(x) + f'(x)| dx \text{ where, } f(x) = \frac{1}{(x-2)^2}; f'(x) = \frac{-2}{(x-2)^3}$$

$$I = \int \frac{e^x}{(x-2)^2} dx - \int \frac{2e^x}{(x-2)^3} dx$$

$$= \frac{e^x}{(x-2)^2} - \int \frac{e^x(-2)}{(x-2)^3} dx - \int \frac{2e^x}{(x-2)^3} dx + C$$

$$\text{So, } I = \frac{e^x}{(x-2)^2} + C$$

13. $A = \{1, 2, 3, 4, 5\}$

$$R = \{(a, b) : |a - b| \text{ is even}\}$$

For R to be an equivalence relation it must be

(i) Reflexive, $|a - a| = 0$

$$\therefore (a, a) \in R \text{ for } \forall a \in A$$

So R is reflexive.

(ii) Symmetric,

if $(a, b) \in R \Rightarrow |a - b|$ is even

$$\Rightarrow |b - a| \text{ is also even}$$

So R is symmetric.

(iii) Transitive

If $(a, b) \in R$ $(b, c) \in R$ then $(a, c) \in R$

$(a, b) \in R \Rightarrow |a - b|$ is even

$(b, c) \in R \Rightarrow |b - c|$ is even

Sum of two even numbers is even

$$\text{So, } |a - b| + |b - c|$$

$$= |a - b + b - c| = |a - c| \text{ is even since } |a - b| \text{ and } |b - c| \text{ are even}$$

So $(a, c) \in R$

Hence, R is transitive.

Therefore, R is an equivalence relation.

14. $(x^2 + y^2)^2 = xy$ —(i)

Differentiating with respect to x, we have,

$$2(x^2 + y^2) \left(2x + 2y \cdot \frac{dy}{dx} \right) = y + \frac{xdy}{dx}$$

$$\Rightarrow 4x(x^2 + y^2) + 4y(x^2 + y^2) \cdot \frac{dy}{dx} = y + \frac{xdy}{dx}$$

$$\Rightarrow \frac{dy}{dx} (4x^2y + 4y^3 - x) = y - 4x^3 - 4xy^2$$

$$\Rightarrow \frac{dy}{dx} = \frac{y - 4x^3 - 4xy^2}{4x^2y + 4y^3 - x}$$

OR

$$y = 3\cos(\log x) + 4\sin(\log x)$$

Differentiating the above function with respect to x, we have,

$$\frac{dy}{dx} = \frac{-3\sin(\log x)}{x} + \frac{4\cos(\log x)}{x}$$

$$x \frac{dy}{dx} = -3\sin(\log x) + 4\cos(\log x)$$

Again differentiating with respect to x, we have,

$$x \frac{d^2y}{dx^2} + \frac{dy}{dx} = \frac{-3\cos(\log x)}{x} - \frac{4\sin(\log x)}{x}$$

$$\Rightarrow x^2 \frac{d^2y}{dx^2} + x \frac{dy}{dx} = -(3\cos(\log x) + 4\sin(\log x))$$

$$\Rightarrow x^2 \frac{d^2y}{dx^2} + x \frac{dy}{dx} = -y$$

$$\Rightarrow x^2 \frac{d^2y}{dx^2} + x \frac{dy}{dx} + y = 0$$

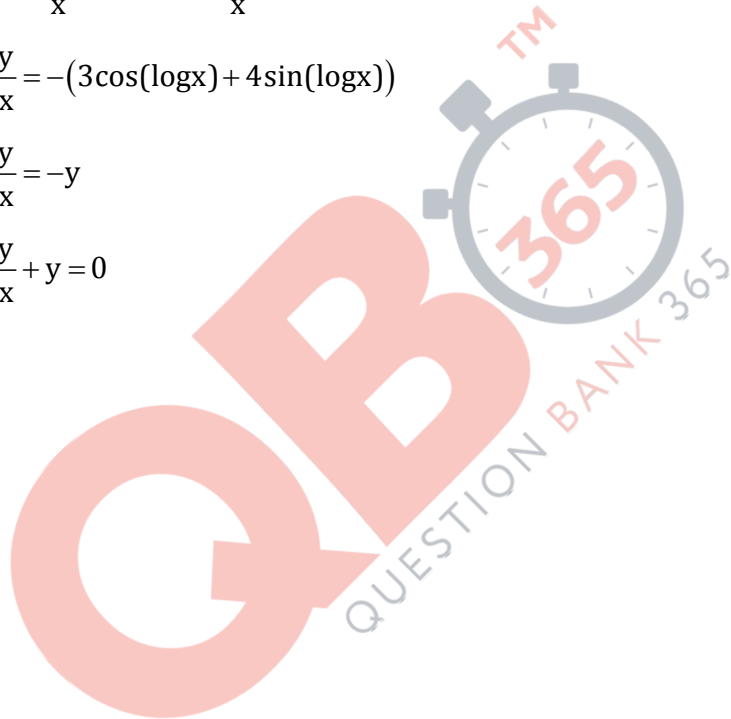

15. Curve $y = \sqrt{3x-2}$

$$\frac{dy}{dx} = \frac{1}{2}(3x-2)^{-\frac{1}{2}} \times 3$$

$$\Rightarrow \frac{dy}{dx} = \frac{3}{2\sqrt{(3x-2)}} \dots (1)$$

Since, the tangent is parallel to the line $4x - 2y = -5$
Therefore, slope of tangent can be obtained from equation

$$y = \frac{4x}{2} + \frac{5}{2}$$

Slope = 2

$$\Rightarrow \frac{dy}{dx} = 2 \dots (2)$$

Comparing equations (1) and (2), we have,

$$\frac{3}{2} \times \frac{1}{\sqrt{3x-2}} = 2$$

$$\Rightarrow \frac{1}{\sqrt{3x-2}} = \frac{4}{3}$$

$$\Rightarrow \frac{1}{3x-2} = \frac{16}{9}$$

$$\Rightarrow 9 = 48x - 32$$

$$\Rightarrow x = \frac{41}{48}$$

We have $y = \sqrt{3x-2}$

Thus, substituting the value of x in the above equation,

$$y = \sqrt{3 \times \frac{41}{48} - 2}$$

$$\Rightarrow y = \sqrt{\frac{41}{16} - 2}$$

$$\Rightarrow y = \sqrt{\frac{41-32}{16}}$$

$$\Rightarrow y = \sqrt{\frac{9}{16}}$$

$$\Rightarrow y = \frac{3}{4}$$

Equation of tangent is

$$\left(y - \frac{3}{4}\right) = 2\left(x - \frac{41}{48}\right)$$

$$\Rightarrow \left(y - \frac{3}{4}\right) = 2x - \frac{41}{24}$$

$$\Rightarrow y = 2x - \frac{41}{24} + \frac{3}{4}$$

$$\Rightarrow y = 2x - \frac{41}{24} + \frac{18}{24}$$

$$\Rightarrow y = 2x - \frac{23}{24}$$

$$\Rightarrow 24y = 48x - 23$$

$$\Rightarrow 48x - 24y - 23 = 0$$

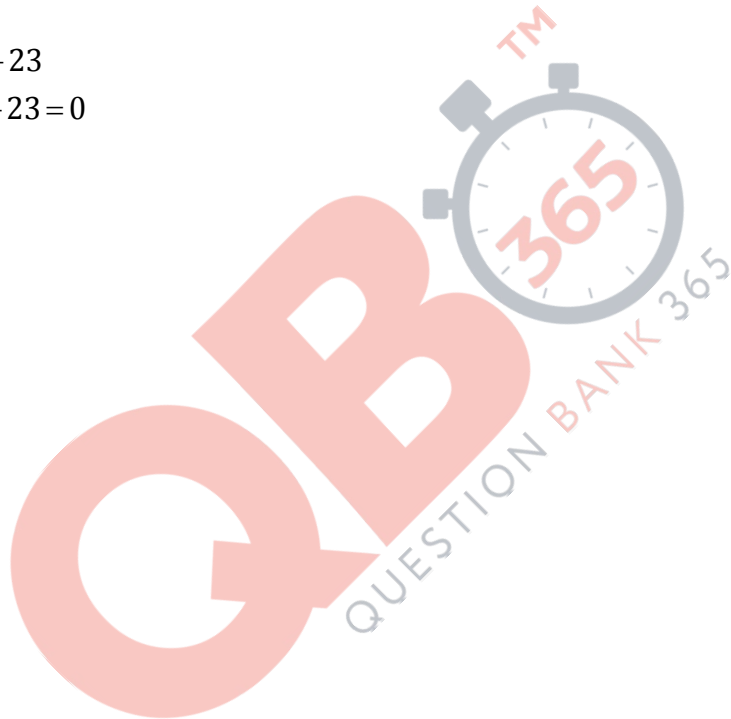

OR

$$f(x) = x^3 + \frac{1}{x^3}, x \neq 0$$

$$\Rightarrow f'(x) = 3x^2 - 3x^{-4} = 3\left(x^2 - \frac{1}{x^4}\right)$$

$$\Rightarrow f'(x) = 3x^2 - 3x^{-4} = \frac{3}{x^4}(x^6 - 1)$$

$$\Rightarrow f'(x) = \frac{3}{x^4}(x^2 - 1)(x^4 + x^2 + 1)$$

$$\Rightarrow f'(x) = 3\left(\frac{x^4 + x^2 + 1}{x^4}\right)(x^2 - 1)$$

(i) For an increasing function, we should have,

$$f'(x) > 0$$

$$\Rightarrow 3\left(\frac{x^4 + x^2 + 1}{x^4}\right)(x^2 - 1) > 0$$

$$\Rightarrow (x^2 - 1) > 0 \quad \left[\because 3\left(\frac{x^4 + x^2 + 1}{x^4}\right) > 0 \right]$$

$$\Rightarrow (x-1)(x+1) > 0$$

$$\Rightarrow x \in (-\infty, -1) \cup x \in (1, \infty)$$

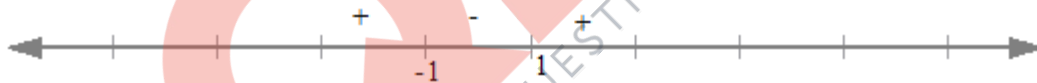

So, $f(x)$ is increasing on $(-\infty, -1) \cup (1, \infty)$

(ii) For a decreasing function, we should have $f'(x) < 0$

$$f'(x) < 0$$

$$\Rightarrow 3\left(\frac{x^4 + x^2 + 1}{x^4}\right)(x^2 - 1) < 0$$

$$\Rightarrow (x^2 - 1) < 0 \quad \left[\because 3\left(\frac{x^4 + x^2 + 1}{x^4}\right) > 0 \right]$$

$$\Rightarrow (x-1)(x+1) < 0$$

$$\Rightarrow x \in (-1, 0) \cup x \in (0, 1)$$

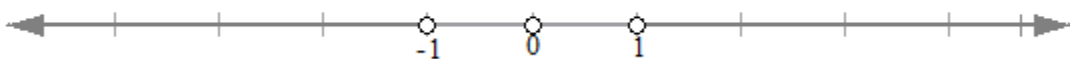

So $f(x)$ is decreasing on $(-1, 0) \cup (0, 1)$

16. Given: $\vec{a} \times \vec{b} = \vec{c} \times \vec{d}$ and $\vec{a} \times \vec{c} = \vec{b} \times \vec{d}$ (i)

To show $\vec{a} - \vec{d}$ is parallel to $\vec{b} - \vec{c}$

$$\text{i.e } (\vec{a} - \vec{d}) \times (\vec{b} - \vec{c}) = 0$$

$$\text{Consider } (\vec{a} - \vec{d}) \times (\vec{b} - \vec{c}) = \vec{a} \times (\vec{b} - \vec{c}) - \vec{d} \times (\vec{b} - \vec{c})$$

$$= \vec{a} \times \vec{b} - \vec{a} \times \vec{c} - \vec{d} \times \vec{b} + \vec{d} \times \vec{c}$$

$$= \vec{c} \times \vec{d} - \vec{b} \times \vec{d} - \vec{d} \times \vec{b} + \vec{d} \times \vec{c} \quad [\because \vec{a} \times \vec{b} = \vec{c} \times \vec{d} \text{ and } \vec{a} \times \vec{c} = \vec{b} \times \vec{d}]$$

$$= \vec{c} \times \vec{d} - \vec{b} \times \vec{d} + \vec{b} \times \vec{d} - \vec{c} \times \vec{d} \quad [\because \vec{d} \times \vec{c} = -\vec{c} \times \vec{d} \text{ and } \vec{d} \times \vec{b} = -\vec{b} \times \vec{d}]$$

$$= 0$$

Therefore $\vec{a} - \vec{d}$ is parallel to $\vec{b} - \vec{c}$.

17.

$$\text{To prove: } \sin^{-1}\left(\frac{4}{5}\right) + \sin^{-1}\left(\frac{5}{13}\right) + \sin^{-1}\left(\frac{16}{65}\right) = \frac{\pi}{2}$$

$$\text{Let } \sin^{-1}\left(\frac{4}{5}\right) = x$$

$$\Rightarrow \sin x = \frac{4}{5}$$

$$\Rightarrow \cos x = \sqrt{1 - \sin^2 x} = \frac{3}{5}$$

$$\sin^{-1}\left(\frac{5}{13}\right) = y$$

$$\Rightarrow \sin y = \frac{5}{13}$$

$$\Rightarrow \cos y = \sqrt{1 - \sin^2 y} = \frac{12}{13}$$

$$\sin^{-1}\left(\frac{16}{65}\right) = z$$

$$\Rightarrow \sin z = \frac{16}{65}$$

$$\Rightarrow \cos z = \sqrt{1 - \sin^2 z} = \frac{63}{65}$$

$$\tan x = \frac{4}{3}, \tan y = \frac{5}{12}, \tan z = \frac{16}{63}$$

$$\tan z = \frac{16}{63} \Rightarrow \cot z = \frac{63}{16} \dots (1)$$

$$\tan(x+y) = \frac{\tan(x+y)}{1 - \tan x \cdot \tan y}$$

$$\Rightarrow \tan(x+y) = \frac{\frac{4}{3} + \frac{5}{12}}{1 - \frac{20}{36}}$$

$$\Rightarrow \tan(x+y) = \frac{63}{16}$$

$$\Rightarrow \tan(x+y) = \cot z \dots [\text{from equation (1)}]$$

$$\Rightarrow \tan(x+y) = \tan\left(\frac{\pi}{2} - z\right)$$

$$\Rightarrow x+y = \frac{\pi}{2} - z$$

$$\Rightarrow x+y+z = \frac{\pi}{2}$$

$$\therefore \sin^{-1}\left(\frac{4}{5}\right) + \sin^{-1}\left(\frac{5}{13}\right) + \sin^{-1}\left(\frac{16}{65}\right) = \frac{\pi}{2}$$

OR

$$\tan^{-1} 3x + \tan^{-1} 2x = \frac{\pi}{4}$$

$$\Rightarrow \tan^{-1}\left(\frac{5x}{1-6x^2}\right) = \frac{\pi}{4}, 3x \times 2x < 1$$

$$\Rightarrow \tan\left[\tan^{-1}\left(\frac{5x}{1-6x^2}\right)\right] = \tan \frac{\pi}{4}$$

$$\Rightarrow \frac{5x}{1-6x^2} = 1$$

$$\Rightarrow 1 - 6x^2 = 5x$$

$$\Rightarrow 6x^2 + 5x - 1 = 0$$

$$\Rightarrow 6x^2 + 6x - x - 1 = 0$$

$$\Rightarrow x = -1 \text{ or } \frac{1}{6}$$

Here $(-3) \times (-2) < 1$ [$\because (-3) \times (-2) = 6 > 1$]

Therefore, $x = -1$ is not the solution.

When substituting $x = \frac{1}{6}$ in $3x \times 2x$, we have,

$$3 \times \frac{1}{6} \times 2 \times \frac{1}{6} = \frac{1}{2} \times \frac{1}{3} = \frac{1}{6} < 1.$$

Hence $x = \frac{1}{6}$ is the solution of the given equation.

18. Given lines are

$$\frac{1-x}{3} = \frac{y-2}{2\lambda} = \frac{z-3}{2}$$

and

$$\frac{x-1}{3\lambda} = \frac{y-1}{1} = \frac{6-z}{7}$$

Let us rewrite the equations of the given lines as follows:

$$\frac{-(x-1)}{3} = \frac{y-2}{2\lambda} = \frac{z-3}{2}$$

and

$$\frac{x-1}{3\lambda} = \frac{y-1}{1} = \frac{-(z-6)}{7}$$

That is we have,

$$\frac{x-1}{-3} = \frac{y-2}{2\lambda} = \frac{z-3}{2}$$

and

$$\frac{x-1}{3\lambda} = \frac{y-1}{1} = \frac{z-6}{-7}$$

The lines are perpendicular so angle between them is 90°

So, $\cos\theta=0$

Here $(a_1, b_1, c_1) = (-3, 2\lambda, 2)$ and $(a_2, b_2, c_2) = (3\lambda, 1, -7)$

For perpendicular lines

$$a_1 a_2 + b_1 b_2 + c_1 c_2 = 0$$

$$\Rightarrow -9\lambda + 2\lambda - 14 = 0$$

$$\Rightarrow -7\lambda - 14 = 0$$

$$\Rightarrow -7\lambda = 14$$

$$\Rightarrow \lambda = \frac{14}{-7}$$

$$\Rightarrow \lambda = -2$$

19.

$$(1+x^2)\frac{dy}{dx} + y = \tan^{-1} x$$

$$\frac{dy}{dx} + \frac{y}{1+x^2} = \frac{\tan^{-1} x}{1+x^2} \text{---(i)}$$

Given equation is linear with

$$\text{So, I.F} = e^{\int \frac{1}{1+x^2} dx} = e^{\tan^{-1} x}$$

Solution of (i)

$$ye^{\tan^{-1} x} = \int e^{\tan^{-1} x} \left(\frac{\tan^{-1} x}{1+x^2} \right) dx \text{(ii)}$$

$$\text{For R.H.S, let } \tan^{-1} x = t \Rightarrow \frac{1}{1+x^2} dx = dt$$

By substituting in equation(ii)

$$ye^{\tan^{-1} x} = \int e^t \cdot t dt$$

$$\Rightarrow y \cdot e^{\tan^{-1} x} = [te^t - e^t] + C$$

$$\Rightarrow ye^{\tan^{-1} x} = e^{\tan^{-1} x} (\tan^{-1} x - 1) + C$$

$$\Rightarrow y = \tan^{-1} x - 1 + Ce^{-\tan^{-1} x}$$

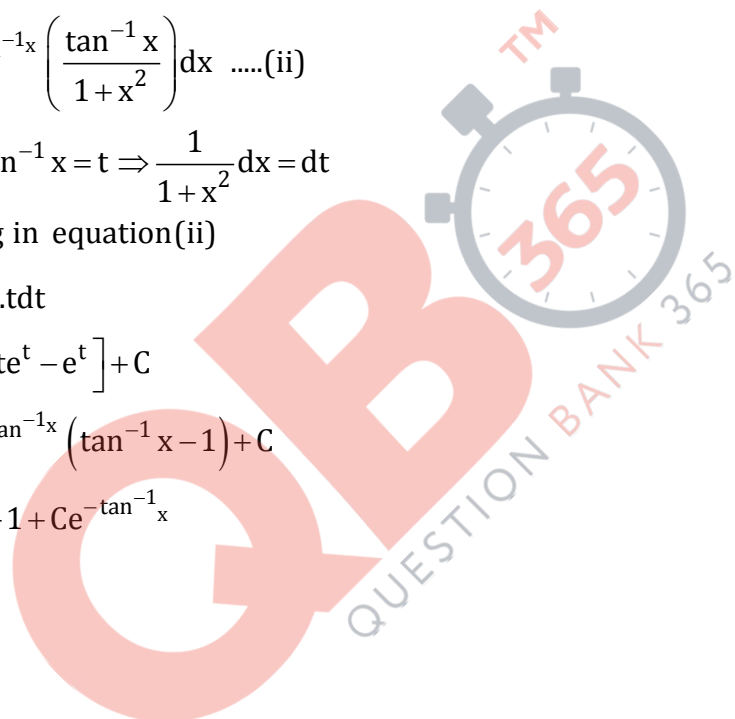

20. $\frac{dy}{dx} - \frac{y}{x} + \operatorname{cosec}\left(\frac{y}{x}\right) = 0$ (i) $y = 0$ when $x = 1$

Let $\frac{y}{x} = t \Rightarrow y = xt$

$$\Rightarrow \frac{dy}{dx} = x \frac{dt}{dx} + t$$

By substituting $\frac{dy}{dx}$ in equation (i)

$$\left(x \frac{dt}{dx} + t\right) - t + \operatorname{cosec} t = 0$$

$$\Rightarrow x \frac{dt}{dx} = -\operatorname{cosec} t$$

$$\Rightarrow \int \frac{dt}{\operatorname{cosec} t} + \int \frac{dx}{x} = 0$$

$$\Rightarrow -\cos t + \log x = C \Rightarrow -\cos\left(\frac{y}{x}\right) + \log x = C$$

using $y = 0$ when $x = 1$

$$-1 + 0 = C \Rightarrow C = -1$$

So the solution is: $\cos\left(\frac{y}{x}\right) = \log x + 1$

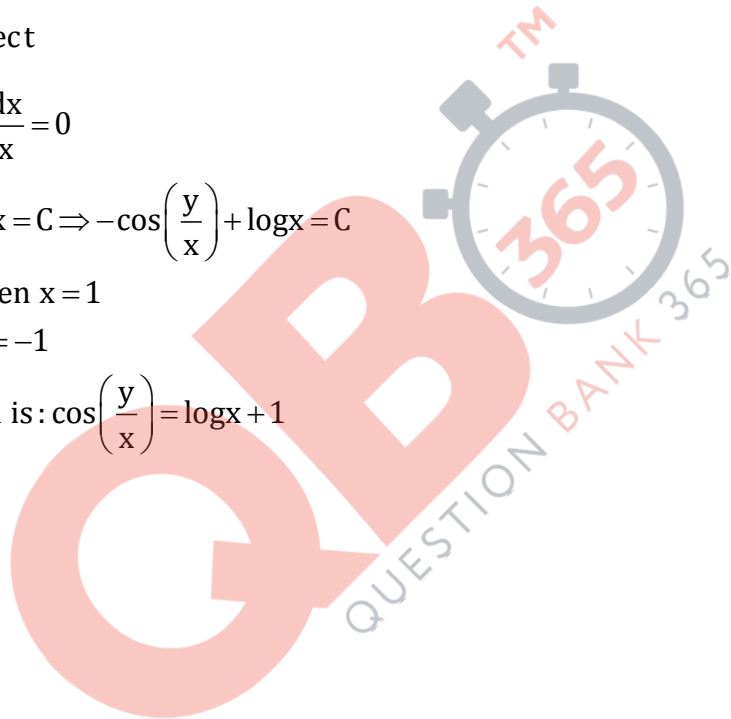

21.

$$\Delta = \begin{vmatrix} a & b & c \\ a-b & b-c & c-a \\ b+c & c+a & a+b \end{vmatrix}$$

Applying $C_1 \rightarrow C_1 + C_2 + C_3$

$$\Delta = \begin{vmatrix} a+b+c & b & c \\ 0 & b-c & c-a \\ 2(a+b+c) & c+a & a+b \end{vmatrix}$$

$$\Delta = (a+b+c) \begin{vmatrix} 1 & b & c \\ 0 & b-c & c-a \\ 2 & c+a & a+b \end{vmatrix}$$

$R_3 \rightarrow R_3 - 2R_1$

$$\Delta = (a+b+c) \begin{vmatrix} 1 & b & c \\ 0 & b-c & c-a \\ 0 & c+a-2b & a+b-2c \end{vmatrix}$$

Expanding along C_1 , we have,

$$\Delta = (a+b+c) [(b-c)(a+b-2c) - (c-a)(c+a-2b)]$$

$$\Rightarrow \Delta = (a+b+c) [(ba + b^2 - 2bc - ca - cb + 2c^2) - (c^2 + ac - 2bc - ac - a^2 + 2ab)]$$

$$\Rightarrow \Delta = (a+b+c)(a^2 + b^2 + c^2 - ca - bc - ab)$$

$$\Rightarrow \Delta = (a+b+c)(a^2 + b^2 + c^2 - ab - bc - ac)$$

$$\Rightarrow \Delta = a^3 + b^3 + c^3 - 3abc = \text{R.H.S.}$$

22. $p =$ probability of success $= \frac{1}{6}$, $q =$ probability of failure $= \frac{5}{6}$

Third six comes at the 6th throw so the remaining two sixes can appear in any of the previous 5 throws.

Probability of obtaining 2 sixes in 5 throws

$$= {}^5C_2 \times \frac{1}{6} \times \frac{1}{6} \times \frac{125}{216}$$

6th throw definitely gives six with probability $= \frac{1}{6}$

Required Probability

$$= \frac{125}{216 \times 36} \times 10 \times \frac{1}{6}$$

$$= \frac{625}{23328}$$

SECTION - C

23. Let E_1 be the event of the first group winning and E_2 be the event of the second group winning and S be the event of introducing a new product.

$$P(E_1) = 0.6 \quad P(E_2) = 0.4$$

$$P(S|E_1) = 0.7$$

$$P(S|E_2) = 0.3$$

Probability of a new product being introduced by the second group will be ,

$$P(E_2|S)$$

$$P(E_2|S) = \frac{P(E_2) \cdot P(S|E_2)}{P(E_1) \cdot P(S|E_1) + P(E_2) \cdot P(S|E_2)}$$

$$= \frac{0.4 \times 0.3}{0.4 \times 0.3 + 0.7 \times 0.6}$$

$$= \frac{0.12}{0.12 + 0.42}$$

$$P(E_2|S) = \frac{12}{54} = \frac{2}{9}$$

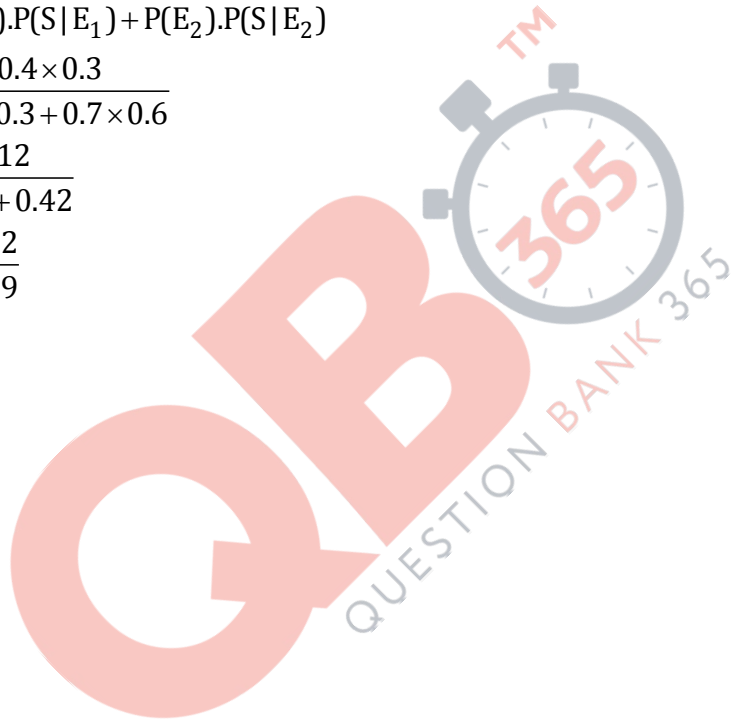

24. $2x - 3y + 5z = 11$

$$3x + 2y - 4z = -5$$

$$x + y - 2z = -3$$

System of equations can be written as $AX = B$

$$\text{Where, } A = \begin{bmatrix} 2 & -3 & 5 \\ 3 & 2 & -4 \\ 1 & 1 & -2 \end{bmatrix}$$

$$X = \begin{bmatrix} x \\ y \\ z \end{bmatrix} \quad B = \begin{bmatrix} 11 \\ -5 \\ -3 \end{bmatrix}$$

$$A = \begin{bmatrix} 2 & -3 & 5 \\ 3 & 2 & -4 \\ 1 & 1 & -2 \end{bmatrix}$$

$$|A| = 2(-4 + 4) + 3(-6 + 4) + 5(3 - 2)$$

$$|A| = -6 + 5 = -1 \neq 0$$

$\therefore A^{-1}$ exists and system of equations has a unique solution

$$A^{-1} = \frac{1}{|A|}(\text{adj}A)$$

$$\text{adj}A = \begin{bmatrix} 0 & -1 & 2 \\ 2 & -9 & 23 \\ 1 & -5 & 13 \end{bmatrix}$$

$$A^{-1} = \frac{1}{|A|} \begin{bmatrix} 0 & -1 & 2 \\ 2 & -9 & 23 \\ 1 & -5 & 13 \end{bmatrix}$$

$$= \begin{bmatrix} 0 & 1 & -2 \\ -2 & 9 & -23 \\ -1 & 5 & -13 \end{bmatrix}$$

$$X = A^{-1}B = \begin{bmatrix} 0 & 1 & -2 \\ -2 & 9 & -23 \\ -1 & 5 & -13 \end{bmatrix} \begin{bmatrix} 11 \\ -5 \\ -3 \end{bmatrix}$$

$$X = \begin{bmatrix} -5 + 6 \\ -22 - 45 + 69 \\ -11 - 25 + 39 \end{bmatrix} = \begin{bmatrix} 1 \\ 2 \\ 3 \end{bmatrix}$$

So $x = 1, y = 2, z = 3$

25.

$$\text{Let } I = \int_0^{\pi} \frac{e^{\cos x}}{e^{\cos x} + e^{-\cos x}} dx$$

$$\text{Using } \int_0^a f(x) dx = \int_0^a f(a-x) dx$$

$$I = \int_0^{\pi} \frac{e^{\cos(\pi-x)}}{e^{\cos(\pi-x)} + e^{-\cos(\pi-x)}} dx$$

$$2I = \int_0^{\pi} \frac{e^{-\cos x} + e^{\cos x}}{e^{\cos x} + e^{-\cos x}} dx$$

$$I = \frac{1}{2} \int_0^{\pi} dx = \frac{1}{2} [\pi - 0] = \frac{\pi}{2}$$

OR

$$I = \int_0^{\frac{\pi}{2}} (2 \log \sin x - \log \sin 2x) dx$$

$$I = \int_0^{\frac{\pi}{2}} \left(\log \frac{\sin^2 x}{2 \sin x \cos x} \right) dx$$

$$I = \int_0^{\frac{\pi}{2}} \log \left(\frac{\tan x}{2} \right) dx \text{---(i)}$$

$$\text{Using property } \int_0^a f(x) dx = \int_0^a f(a-x) dx$$

We get,

$$I = \int_0^{\frac{\pi}{2}} \log \left(\frac{\tan \left(\frac{\pi}{2} - x \right)}{2} \right) dx$$

$$\Rightarrow I = \int_0^{\frac{\pi}{2}} \log \left(\frac{\cot x}{2} \right) dx \text{---(ii)}$$

Adding (i) &(ii)

$$2I = \int_0^{\frac{\pi}{2}} \left[\log\left(\frac{\tan x}{2}\right) + \log\left(\frac{\cot x}{2}\right) \right] dx$$

$$\Rightarrow 2I = \int_0^{\frac{\pi}{2}} \log\left[\left(\frac{\tan x}{2}\right)\left(\frac{\cot x}{2}\right)\right] dx$$

$$\Rightarrow I = \frac{1}{2} \int_0^{\frac{\pi}{2}} \log\left(\frac{1}{4}\right) dx$$

$$\Rightarrow I = \frac{1}{2} \log\left(\frac{1}{4}\right) \times \left(\frac{\pi}{2}\right)$$

$$\Rightarrow I = \frac{1}{2} \log\left(\frac{1}{4}\right)^{\frac{1}{2}} \times \left(\frac{\pi}{2}\right)$$

$$\Rightarrow I = \log\left(\frac{1}{2}\right) \times \left(\frac{\pi}{2}\right)$$

$$\Rightarrow I = \frac{\pi}{2} \log \frac{1}{2}$$

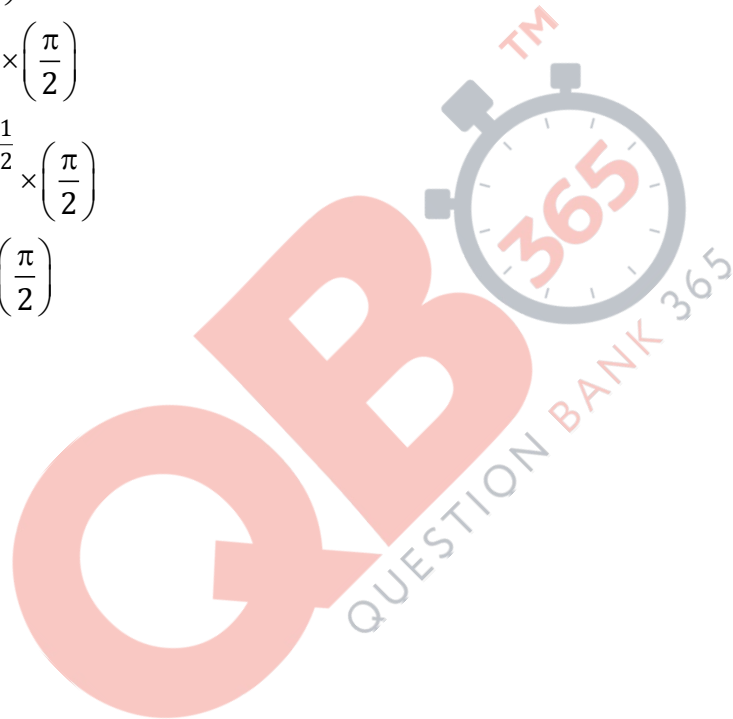

26. The point of intersection of the
Parabolas $y^2 = 4x$ and $x^2 = 4y$ are $(0, 0)$ and $(4, 4)$

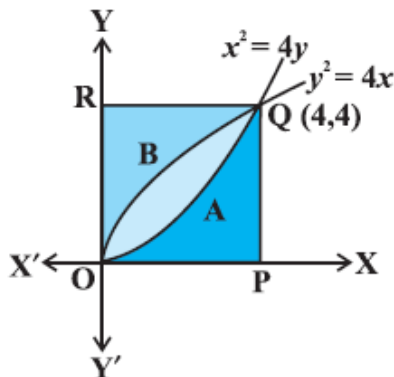

Now, the area of the region OAQBO bounded by curves $y^2 = 4x$ and $x^2 = 4y$,

$$\int_0^4 \left(2\sqrt{x} - \frac{x^2}{4} \right) dx = \left[2 \frac{x^{\frac{3}{2}}}{\frac{3}{2}} - \frac{x^3}{12} \right]_0^4 = \frac{32}{3} - \frac{16}{3} = \frac{16}{3} \text{ sq units} \dots\dots\dots(i)$$

Again, the area of the region OPQAO bounded by the curves $x^2 = 4y$, $x = 0$, $x = 4$ and the x-axis,

$$\int_0^4 \frac{x^2}{4} dx = \left[\frac{x^3}{12} \right]_0^4 = \left(\frac{64}{12} \right) = \frac{16}{3} \text{ sq units} \dots\dots\dots(ii)$$

Similarly, the area of the region OBQRO bounded by the curve $y^2 = 4x$, the y-axis, $y = 0$ and $y = 4$

$$\int_0^4 \frac{y^2}{4} dy = \left[\frac{y^3}{12} \right]_0^4 = \frac{16}{3} \text{ sq units} \quad (iii)$$

From (i), (ii), and (iii) it is concluded that the area of the region OAQBO = area of the region OPQAO = area of the region OBQRO, i.e., area bounded by parabolas $y^2 = 4x$ and $x^2 = 4y$ divides the area of the square into three equal parts.

27. Let the equation of the plane be,

$$A(x - x_1) + B(y - y_1) + C(z - z_1) = 0$$

Plane passes through the point (-1, 3, 2)

$$\therefore A(x+1) + B(y-3) + C(z-2) = 0 \text{ (i)}$$

Now applying the condition of perpendicularity to the plane (i) with planes

$x + 2y + 3z = 5$ and $3x + 3y + z = 0$, we have

$$A + 2B + 3C = 0$$

$$3A + 3B + C = 0$$

Solving we get

$$A + 2B + 3C = 0$$

$$9A + 9B + 3C = 0$$

By cross multiplication, we have,

$$\frac{A}{2 \times 3 - 9 \times 3} = \frac{B}{9 \times 3 - 1 \times 3} = \frac{C}{1 \times 9 - 2 \times 9}$$

$$\Rightarrow \frac{A}{6 - 27} = \frac{B}{27 - 3} = \frac{C}{9 - 18}$$

$$\Rightarrow \frac{A}{-21} = \frac{B}{24} = \frac{C}{-9}$$

$$\Rightarrow \frac{A}{7} = \frac{B}{-8} = \frac{C}{3}$$

$$\Rightarrow A = 7\lambda; B = -8\lambda; C = 3\lambda$$

By substituting A and C in equation (i), we get,

Substituting the values of A, B and C in equation (i), we have,

$$7\lambda(x+1) - 8\lambda(y-3) + 3\lambda(z-2) = 0$$

$$\Rightarrow 7x + 7 - 8y + 24 + 3z - 6 = 0$$

$$\Rightarrow 7x - 8y + 3z + 25 = 0$$

28. The given sphere is of radius R . Let h be the height and r be the radius of the cylinder inscribed in the sphere.

Volume of cylinder

$$V = \pi R^2 h \quad \dots(1)$$

In right angled triangle ΔOBA

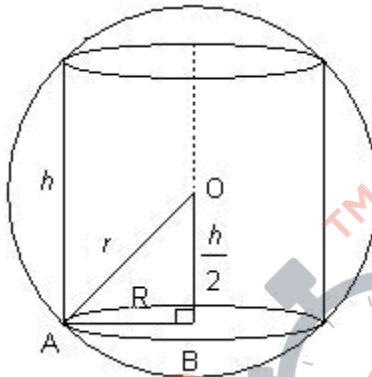

$$AB^2 + OB^2 = OA^2$$

$$R^2 + \frac{h^2}{4} = r^2$$

$$\text{So, } R^2 = r^2 - \frac{h^2}{4}$$

Putting the value of R^2 in equation (1), we get

$$V = \pi \left(r^2 - \frac{h^2}{4} \right) \cdot h$$

$$V = \pi \left(r^2 h - \frac{h^3}{4} \right) \quad \dots(3)$$

$$\therefore \frac{dV}{dh} = \pi \left(r^2 - \frac{3h^2}{4} \right) \quad \dots(4)$$

For stationary point, $\frac{dV}{dh} = 0$

$$\pi \left(r^2 - \frac{3h^2}{4} \right) = 0$$

$$r^2 = \frac{3h^2}{4} \quad \Rightarrow h^2 = \frac{4r^2}{3} \quad \Rightarrow h = \frac{2r}{\sqrt{3}}$$

$$\text{Now } \frac{d^2V}{dh^2} = \pi \left(-\frac{6}{4} h \right)$$

$$\therefore \left[\frac{d^2V}{dh^2} \right]_{\text{at } h = \frac{2r}{\sqrt{3}}} = \pi \left(-\frac{3}{2} \cdot \frac{2r}{\sqrt{3}} \right) < 0$$

∴ Volume is maximum at $h = \frac{2r}{\sqrt{3}}$

Maximum volume is

$$= \pi \left(r^2 \times \frac{2r}{\sqrt{3}} - \frac{1}{4} \times \frac{8r^3}{3\sqrt{3}} \right)$$

$$= \pi \left(\frac{2r^3}{\sqrt{3}} - \frac{2r^3}{3\sqrt{3}} \right)$$

$$= \pi \left(\frac{6r^3 - 2r^3}{3\sqrt{3}} \right)$$

$$= \frac{4\pi r^3}{3\sqrt{3}} \text{ cu. unit}$$

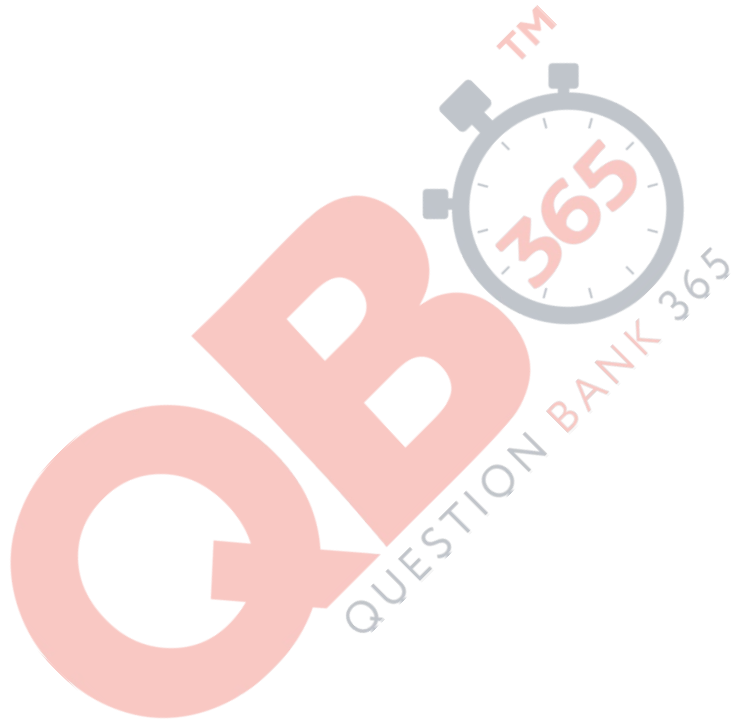

OR

Let ℓ , b , and h denote the length breadth and depth of the open rectangular tank.

Given $h = 2\text{m}$

$$V = 8\text{m}^3$$

$$\text{i.e } 2\ell b = 8$$

$$\Rightarrow \ell b = 4 \text{ or } b = \frac{4}{\ell}$$

Surface area, S , of the open rectangular tank of depth ' h ' = $\ell b + 2(\ell + b) \times h$

In this problem, $b = \frac{4}{\ell}$, $\ell b = 4$ metre, $h = 2$ metre

$$\therefore S = 4 + 2\left(\ell + \frac{4}{\ell}\right) \times 2$$

$$\Rightarrow S = 4 + 4\left(\ell + \frac{4}{\ell}\right)$$

For maxima or minima, differentiating with respect to ℓ we get,

$$\frac{dS}{d\ell} = 4\left(1 - \frac{4}{\ell^2}\right)$$

$$\frac{dS}{d\ell} = 0 \Rightarrow \ell = 2\text{m}$$

$\ell = 2\text{m}$ for minimum or maximum

$$\text{Now, } \frac{d^2S}{d\ell^2} = \frac{48}{\ell^3} > 0 \text{ for all } \ell$$

So $\ell = 2\text{m}$ is a point of minima and minimum surface area is

$$S = \ell b + 2(\ell + b) \times h$$

$$= 4 + 2 \times 8 = 4 + 16 = 20 \text{ square metres}$$

Base Area = 4 square metres; Lateral surface area = 16 square metres

$$\text{cost} = 4 \times 70 + 16 \times 45$$

$$= 280 + 720 = \text{Rs. } 1000$$

29. Let x be the number of units of food F_1 and y be the number of units of food F_2 .

LPP is,

Minimize $Z = 4x + 6y$ such that,

$$3x + 6y \geq 80$$

$$4x + 3y \geq 100$$

$$x, y \geq 0$$

Representing the LPP graphically

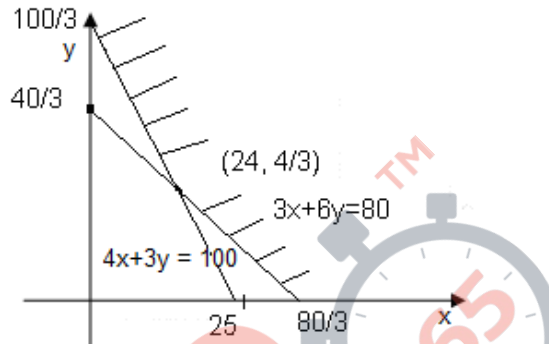

Corner points are $\left[0, \frac{100}{3}\right], \left[24, \frac{4}{3}\right], \left[\frac{80}{3}, 0\right]$

Point	Cost = $4x + 6y$
$\left(0, \frac{100}{3}\right)$	$4 \times 0 + 6 \times \frac{100}{3} = 0 + 200 = 200$
$\left(24, \frac{4}{3}\right)$	$4 \times 24 + 6 \times \frac{4}{3} = 96 + 8 = 104$
$\left(\frac{80}{3}, 0\right)$	$4 \times \frac{80}{3} + 6 \times 0 = \frac{320}{3} + 0 = 106.67$

From the table it is clear that, minimum cost is 104 and occurs at the point $\left(24, \frac{4}{3}\right)$.