

**CBSE Board
Class XII Physics – Set 1
Board Paper - 2012**

Time: 3 hours

Total Marks: 70

General Instructions:

1. All questions are compulsory.
2. There are 30 questions in total Questions 1 to 8 are very short answer type questions and carry one mark each.
3. Questions 9 to 18 carry two marks each, questions 19 to 27 carry three marks each and questions 28 to 30 carry five marks each.
4. There is no overall choice. However, an internal choice has been provided in one question of two marks, one question of three marks and all three questions of five marks each. You have to attempt only one of the given choices in such questions.
5. Use of calculators is not permitted. However, you may use log tables if necessary.
6. You may use the following values of physical constants wherever necessary.

$$c = 3 \times 10^8 \text{ ms}^{-1}$$

$$h = 6.626 \times 10^{-34} \text{ Js}$$

$$e = 1.602 \times 10^{-19} \text{ C}$$

$$\mu_0 = 4\pi \times 10^{-7} \text{ TmA}^{-1}$$

$$\frac{1}{4\pi\epsilon_0} = 9 \times 10^9 \text{ Nm}^2\text{C}^{-2}$$

$$\text{Mass of electron } m_e = 9.1 \times 10^{-31} \text{ kg}$$

$$\text{Mass of neutron } m_n \cong 1.675 \times 10^{-27} \text{ kg}$$

$$\text{Boltzmann's constant } k = 1.381 \times 10^{-23} \text{ J K}^{-1}$$

$$\text{Avogadro's number } N_A = 6.022 \times 10^{23} \text{ mol}^{-1}$$

$$\text{Radius of earth} = 6400 \text{ km}$$

1. When electrons drift in a metal from lower to higher potential, does it mean that all the free electrons of the metal are moving in the same direction?
2. The horizontal component of the earth's magnetic field at a place is B and angle of dip is 60° . What is the value of vertical component of earth's magnetic field at equator?
3. Show on a graph, the variation of resistivity with temperature for a typical semiconductor.

QB365 - Question Bank Software

4. Why should electrostatic field be zero inside a conductor?
5. Name the physical quantity which remains same for microwaves of wavelength 1 mm and UV radiations of 1600 \AA in vacuum.
6. Under what condition does a biconvex lens of glass having a certain refractive index act as a plane glass sheet when immersed in liquid?
7. Predict the directions of induced currents in metal rings 1 and 2 lying in the same plane where current I in the wire is increasing steadily.



8. State de-Broglie hypothesis.
9. A ray of light, incident on an equilateral glass prism ($\mu_g = \sqrt{3}$) moves parallel to the base line of the prism inside it. Find the angle of incidence for this ray.
10. Distinguish between 'Analog and Digital signals'.

OR

Mention the function of any two of the following used in communication system:

- (i) Transducer
- (ii) Repeater
- (iii) Transmitter
- (iv) Bandpass Filter

QB365 - Question Bank Software

11. A cell of emf E and internal resistance r is connected to two external resistances R_1 and R_2 and a perfect ammeter. The current in the circuit is measured in four different situations:

(i) Without any external resistance in the circuit

(ii) With resistance R_1 only

(iii) With R_1 and R_2 in series combination

(iv) With R_1 and R_2 in parallel combination

The currents measured in the four cases are 0.42 A, 1.05 A, 1.4 A and 4.2 A, but not necessarily in that order. Identify the current corresponding to the four cases mentioned above.

12. The susceptibility of a magnetic material is -2.6×10^{-5} . Identify the type of magnetic material and state its two properties.

13.

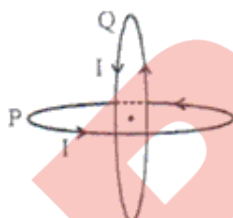

Two identical circular wires P and Q each of radius R and carrying current 'I' are kept in perpendicular planes such that they have a common centre as shown in the figure. Find the magnitude and direction of the net magnetic field at the common centre of two coils.

14. When an ideal capacitor is charged by dc battery, no current flows. However, when an ac source is used, the current flows continuously. How does one explain this, based on the concept of displacement current?

15. Draw a plot showing the variation of (i) electric field (E) and (ii) electric potential (V) with distance r due to a point charge Q .

16. Define self-inductance of a coil. Show that magnetic energy required to build up the current I in a coil of self inductance L is given by $\frac{1}{2} LI^2$.

17. The current in the forward bias is known to be more ($\sim \text{mA}$) than the current in the reverse bias ($\sim \mu\text{A}$). What is the reason, then, to operate the photodiode in reverse bias?

QB365 - Question Bank Software

18. A metallic rod of 'L' length is rotated with angular frequency of ' ω ' with one end hinged at the centre and the other end at the circumference of a circular metallic ring of radius L, about an axis passing through the centre and perpendicular to the plane of the ring. A constant and uniform magnetic field B parallel to the axis is present everywhere. Deduce the expression for the emf between the centre and the metallic ring.
19. The figure shows a series LCR circuit with $L = 5.0 \text{ H}$, $C = 80 \text{ } \mu\text{F}$, $R = 40 \text{ } \Omega$ connected to variable frequency 240 V source. Calculate

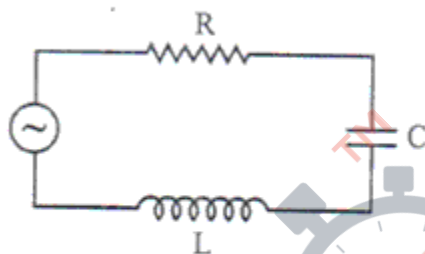

- (i) The angular frequency of the source which drives the circuit at resonance.
(ii) The current at the resonating frequency.
(iii) The rms potential drop across the capacitor at resonance.
20. A rectangular loop of wire of size $4 \text{ cm} \times 10 \text{ cm}$ carries a steady current of 2 A. A straight long wire carrying 5 A current is kept near the loop as shown. If the loop and the wire are coplanar, find

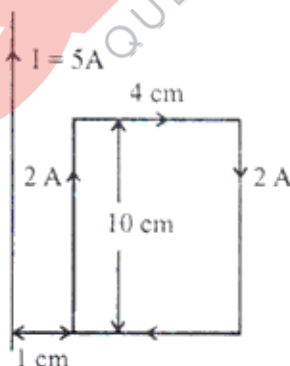

21. (a) Using Bohr's second postulate of quantization of orbital angular momentum show that the circumference of the electron in the n^{th} orbital state in hydrogen atom is n times the de Broglie wavelength associated with it.
- (b) The electron in hydrogen atom is initially in the third excited state. What is the maximum number of spectral lines which can be emitted when it finally moves to the ground state?

QB365 - Question Bank Software

22. In the figure a long uniform potentiometer wire AB is having a constant potential gradient along its length. The null points for the two primary cells of emfs ϵ_1 and ϵ_2 connected in the manner shown are obtained at a distance of 120 cm and 300 cm from the end A. Find (i) ϵ_1 / ϵ_2 and (ii) position of null point for the cell ϵ_1 . How is the sensitivity of a potentiometer increased?

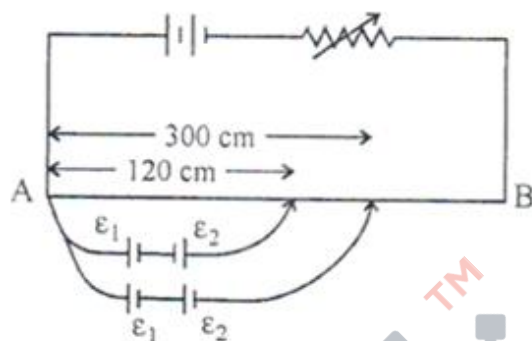

OR

Using Kirchoff's rules determine the value of unknown resistance R in the circuit so that no current flows through 4Ω resistance. Also find the potential difference between A and D.

23. (i) What characteristic property of nuclear force explains the constancy of binding energy per nucleon (BE/A) in the range of mass number 'A' lying $30 < A < 170$?
- (ii) Show that the density of nucleus over a wide range of nuclei is constant-independent of mass number A.
24. Write any two factors which justify the need for modulating a signal. Draw a diagram showing an amplitude modulated wave by superposing a modulating signal over a sinusoidal carrier wave.
25. Write Einstein's photoelectric equation. State clearly how this equation is obtained using the photon picture of electromagnetic radiation. Write the three salient features observed in photoelectric effect which can be explained using this equation.
26. (a) Why are coherent sources necessary to produce a sustained interference pattern?
- (b) In Young's double slit experiment using monochromatic light of wavelength λ , the intensity of light at a point on the screen where path difference is λ , is K units. Find out the intensity of light at a point where path difference is $\lambda/3$.
27. Use Huygens's principle to explain the formation of diffraction pattern due to a single slit illuminated by a monochromatic source of light.
- When the width of the slit is made double the original width, how would this affect the size and intensity of the central diffraction band?

QB365 - Question Bank Software

28. Explain the principle of a device that can build up high voltages of the order of few million volts.

Draw a schematic diagram and explain the working of this device.

Is there any restriction on the upper limit of the high voltages set up in this machine? Explain.

OR

(a) Define electric flux. Write its S.I units.

(b) Using Gauss's law, prove that the electric field at a point due to a uniformly charged infinite plane sheet is independent of the distance from it.

(c) How is the field directed if (i) the sheet is positively charged, (ii) negatively charged?

29. Define magnifying power of a telescope. Write its expression.

A small telescope has an objective lens of focal length 150 cm and an eye piece of focal length 5 cm. If this telescope is used to view a 100 m high tower 3 km away, find the height of the final image when it is formed 25 cm away from the eye piece.

OR

How is the working of a telescope different from that of a microscope? The focal lengths of the objective and eyepiece of microscope are 1.25 cm and 5 cm respectively. Find the position of the object relative to the objective in order to obtain an angular magnification of 30 in normal adjustment.

30. Draw a simple circuit of CE transistor amplifier. Explain its working. Show that the voltage gain, A_v , of the amplifier is given by $A_v = \frac{\beta_{ac} R_L}{r_i}$, where β_{ac} is the current gain, R_L is the load resistance and r_i is the input resistance of the transistor. What is the significance of the negative sign in the expression for the voltage gain?

OR

(a) Draw the circuit diagram of a full wave rectifier using p-n junction diode. Explain its working and show the output, input waveforms.

(b) Show the output waveforms (Y) for the following inputs A and B of

- (i) OR gate (ii) NAND gate

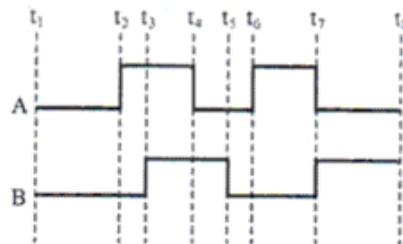

**CBSE Board
Class XII Physics – Set 1
Board Paper – 2012 (Solution)**

1. No it does not mean that all the electrons are moving in the same direction as the drift velocity means average velocity. Electrons are accelerating towards higher potential, having collisions and again accelerating towards higher potential.
2. At equator the magnetic field is horizontal so its vertical component is zero.
3. For semiconductor, the resistivity decreases with increase in temperature.



- If the electric field inside the conductor is not zero, the electrons will accelerate due to the electric field and for the electrostatic condition the net field becomes zero due to the redistribution of the charge carriers and electrons come at rest (electrostatics).
4. If the electric field inside the conductor is not zero, the electrons will accelerate due to the electric field and for the electrostatic condition the net field becomes zero due to the redistribution of the charge carriers and electrons come at rest (electrostatics).
 5. Both the microwaves and UV radiations are electromagnetic waves, and their speed is same in vacuum.
 6. If the RI of the lens and the liquid is same.
 7. In loop 1 clockwise and in loop 2 anticlockwise by applying Lenz's law.
 8. de Broglie's hypothesis states that electrons revolving in their circular orbit, as proposed by Bohr behave like wave. For an electron moving in n^{th} circular orbit of radius r_n , the total distance travelled by it in a complete time period will be: circumference of the orbit, ie,
$$2\pi r_n = n\lambda \quad \text{where, } n=1,2,3\dots$$

QB365 - Question Bank Software

9. As the light ray is parallel inside the prism, so $r_1=r_2$. I.e,

$$2r = 60^\circ \text{ as equilateral prism,}$$



$$r = 30^\circ$$

$$\sqrt{3} = \frac{\sin i}{\sin 30}$$

$$\sin i = \frac{\sqrt{3}}{2}$$

$$i = 60^\circ$$

- 10.

Analog signal	Digital signal
1. Analog signal is in the form of a continuous wave. eg, sine wave. 2. Analog signal looks like:	1. Digital signal is in the form of a pulse code ie, 0 and 1. Digital signal looks like:
	

OR

Functions of:

- (i) **Transducer:** It converts one form of energy to another. Or it converts some physical variable like: pressure, displacement etc to corresponding variation in electrical signal.
- (ii) **Repeater:** It picks up signal from transmitter and then amplifies it and further retransmits it to the receiver.
Repeaters are used to extend the range of communication.
- (iii) **Transmitter:** It makes the incoming signal suitable for transmission.

Band pass filter: It rejects ie, filters low and high frequencies and allows a band of frequencies to pass through.

11. Current in case I

(i) $i_1 = \frac{E}{r}$

- (ii) Current in case II

$$i_2 = \frac{E}{r + R_1}$$

- (iii) Current in case III

$$i_3 = \frac{E}{r + R_1 + R_2}$$

- (iv) Current in case IV

$$i_4 = \frac{E}{r + \frac{R_1 R_2}{R_1 + R_2}}$$

Logically from the above expressions,
 $i_3 < i_2 < i_4 < i_1$

So, $i_1 = 4.2 \text{ A}$ $\left(\frac{1}{2}\right)$

$$i_4 = 1.4 \text{ A} \quad \left(\frac{1}{2}\right)$$

$$i_2 = 1.05 \text{ A} \quad \left(\frac{1}{2}\right)$$

$$i_3 = 0.42 \text{ A} \quad \left(\frac{1}{2}\right)$$

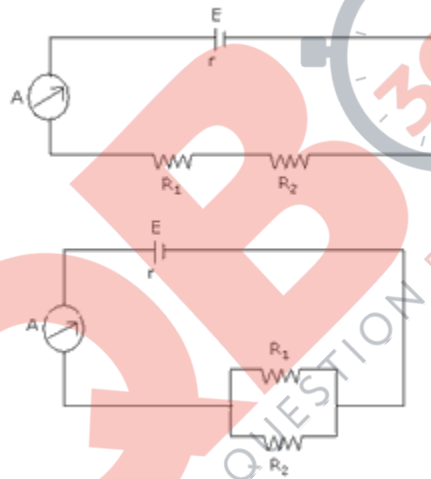

12. As the magnetic material has negative susceptibility, so it is diamagnetic material. Two properties of these types of materials are:
- (i) When these materials are kept in external magnetic field then a net magnetic moment is developed inside the material in opposite direction.
 - (ii) When diamagnetic substances are kept in nonuniform external magnetic field then they move from stronger to weaker field.

13.

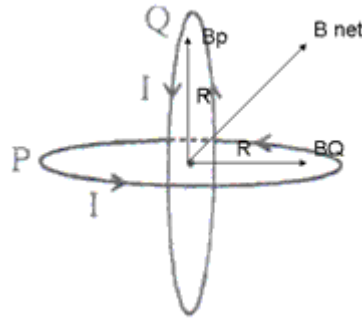

Due to Q coil direction of magnetic field is along \vec{B}_Q at centre

Due to P coil direction of magnetic field is along \vec{B}_P at centre

The net magnet field will be a \vec{B}_{net} and along the direction given in the figure.

$$|\vec{B}_{net}| = \sqrt{|\vec{B}_P|^2 + |\vec{B}_Q|^2} = \sqrt{\left(\frac{\mu_0 I}{2R}\right)^2 + \left(\frac{\mu_0 I}{2R}\right)^2} = \frac{\mu_0 I}{\sqrt{2}R}$$

14.

When the DC battery is connected the current flows for very short time until the capacitor is charged but when the AC source is connected the capacitor become charged and discharge alternatively. Displacement current is due to the variation in electric field .

In DC case if we apply Ampere's circuital law and consider surface inside or outside the capacitor there will be no current and there is no magnetic field. But in the case of AC if one apply Ampere's law there will be always a magnetic field and one can justify it by taking the surface outside or inside the capacitor plates as outside capacitor plates there is a conducting current and inside the capacitor plates there is a displacement current due to variation in electric field between the plates of the capacitor.

QB365 - Question Bank Software

15. E at a point varies inversely as the square of its distance from Q .
 V at a point varies inversely as its distance from point charge Q

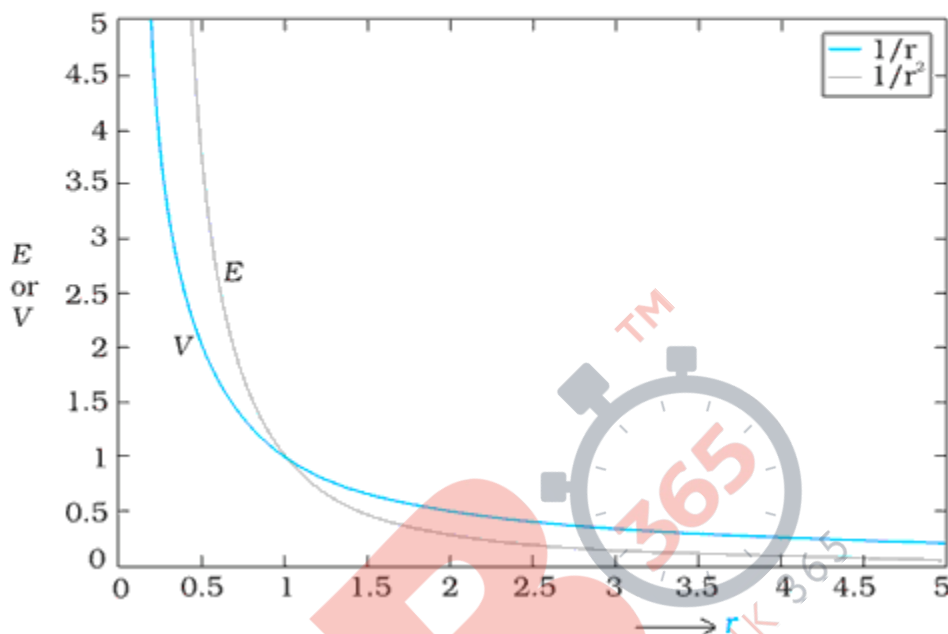

16. If a current I passes through a single coil of any shape, it will produce a magnetic field \vec{B} . This field will have a flux ϕ through the coil itself.

Since $B \propto I$, $\therefore \phi \propto I$

\therefore , If I changes,

$$\frac{d\phi}{dt} = (\text{constant}) \frac{dI}{dt}$$

This will induce an emf in itself, given by:

$$\varepsilon = -\frac{d\phi}{dt} = -L \frac{dI}{dt}$$

where L is a constant of proportionality called **self inductance**. It depends only on the shape of the coil.

Since setting up a current leads to producing a magnetic field by the coil whose flux increases as the current increases, by Lenz's law, an emf $\varepsilon = -\frac{d\phi_1}{dt}$ is induced which opposes this flow of current.

So, work has to be done against this emf by a countering emf $\varepsilon_c = -\varepsilon = \frac{L dI}{dt}$

The power used up in this process is

$$P = \frac{dW}{dt} = \varepsilon_c I = LI \frac{dI}{dt}$$

$$\therefore dW = LI dI$$

So, in setting up a current I from zero to value I , work required

$$W = L \int_0^I I dI = \frac{1}{2} LI^2$$

This work is not dissipated (unlike in a resistance due to joule losses), but is stored as magnetic energy.

QB365 - Question Bank Software

17. Photodiode is used to measure the change in the intensity of light that falls on the PN junction diode. The current changes due to the change in intensity of light that falls on.

The PN junction. In forward biasing the current is high in comparison to reverse biasing so the change in the current due to light is noticeable only in reverse biasing only, that's why we use photodiode is used in reverse biasing.

18. Method I

As the rod is rotated, free electrons in the rod move towards the outer end due to Lorentz force and get distributed over the rod. Thus, the resulting separation of charges procures an emf across the ends of the rod. At a certain value of emf, there is no more flow of electrons and a steady state is reached. Using eq., the magnitude of the emf generated across a length dr of the rod as it moves at right angles to the magnetic field is given by

$d\varepsilon = Bv \cdot dr$. Hence,

$$\varepsilon = \int d\varepsilon = Bv \cdot dr = \int_0^R B \omega r \cdot dr = \frac{B\omega R^2}{2}$$

OR

Method II

To calculate the emf, we can imagine a closed loop OPQ in which point O and P are connected with R and OQ is the rotating rod. The potential difference across the resistor is then equal to the induced emf and equals $B \times$ (rate of change of area of loop). If θ is the angle between the rod and the radius of the circle at P at time t , the area of the sector OPQ is given by

$$\pi R^2 \times \frac{\theta}{2\pi} = \frac{1}{2} R^2 \theta$$

where R is the radius of the circle. Hence, the induced emf is

$$\varepsilon = B \times \frac{d}{dt} \left[\frac{1}{2} R^2 \theta \right] = \frac{1}{2} BR^2 \frac{d\theta}{dt} = \frac{B\omega R^2}{2}$$

$$\left[\text{Note : } \frac{d\theta}{dt} = \omega = 2\pi\nu \right]$$

19. $L = 5.0$

$$\begin{aligned}C &= 80 \mu \\R &= 40 \Omega \\e &= 240 \text{ v.}\end{aligned}$$

(i) $\omega = \frac{1}{\sqrt{LC}}$ = angular frequency

$$\begin{aligned}&= \frac{1}{\sqrt{5 \times 80 \times 10^{-6}}} \\&= \frac{1}{\sqrt{4 \times 10^{-4}}} = \frac{1}{2 \times 10^{-2}} = \frac{100}{2} = 50 \text{ Hz.}\end{aligned}$$

$I = \frac{e}{R}$ as $X_L = X_C$

(ii) $= \frac{20}{4}$

$\therefore I$ at resonating frequency = 6 A

(iii) $V_{\text{rms}} = I_{\text{rms}} X_C$

$$X_C = \frac{1}{\omega C} = \frac{1}{50 \times 80 \times 10^{-6}}$$

$$\begin{aligned}\therefore V_{\text{rms}} &= \frac{6}{\frac{50 \times 80 \times 10^{-6}}{= 1500 \text{ V}}} = \frac{6}{4000 \times 10^{-6}} = \frac{6}{4} \times 10^3 \\&= 1500 \text{ V}\end{aligned}$$

20.

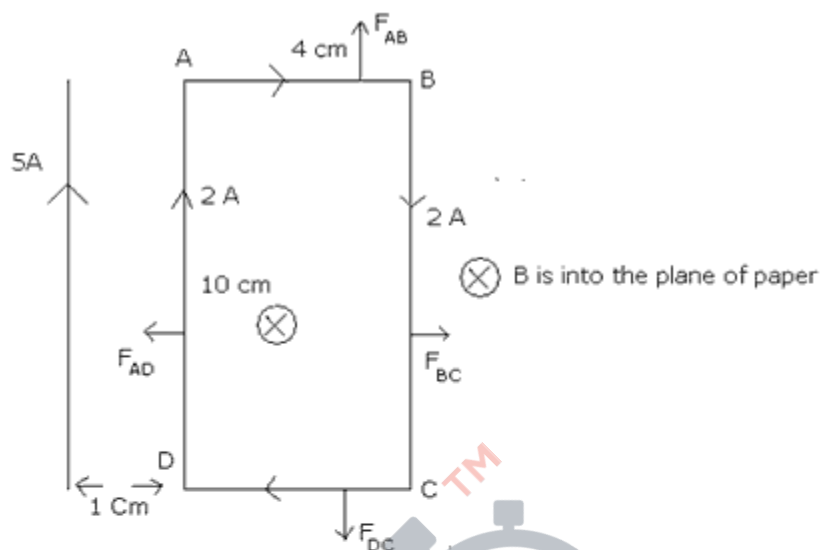

F_{AB} and F_{DC} are equal and opposite so they will cancel each other.

$$\Rightarrow F_{AD} = \frac{\mu_0 I_a I_b}{2\pi \times d} \times L = \frac{2 \times 10^{-7} \times 5 \times 2 \times (10 \times 10^{-2})}{(1 \times 10^{-2})}$$

$$\Rightarrow F_{BC} = \frac{(2 \times 10^{-7}) \times 5 \times 2 \times (10 \times 10^{-2})}{(1+4) \times 10^{-2}}$$

$$= 4 \times 10^{-6} \text{ (towards right)}$$

$$= F_{net} = (F_{AD} - F_{BC}) = 2 \times 10^{-5} - 0.4 \times 10^{-5}$$

$$= 10^{-5} (1.6) \text{ (towards right)}$$

\Rightarrow Torque will be zero as all the forces are in the plane of loop.

21. (a) Bohr's second Postulate says

$$2\pi r = \frac{nh}{mv}$$

$$2\pi r = \frac{nh}{mv}$$

Circumference of the orbit = $2\pi r$

$$\text{So } \frac{h}{mv} = \lambda = \text{wavelength}$$

\Rightarrow circumference = h (wave length)

(b)

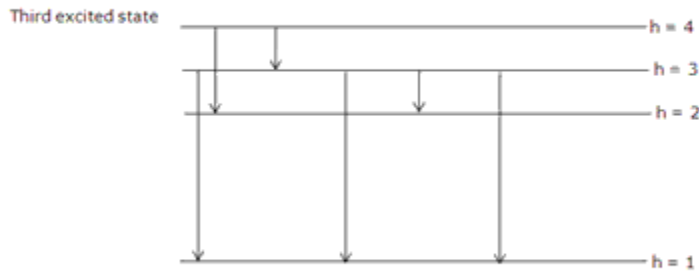

From the above diagram it is clear that there are maximum 6 spectral lines are possible

22. As $v \propto L$ in potentiometer,

$$\frac{\epsilon_1 + \epsilon_2}{\epsilon_1 - \epsilon_2} = \frac{300}{120}$$

$$\therefore \frac{\epsilon_1 + \cancel{\epsilon_2} + \epsilon_1 + \cancel{-\epsilon_2}}{\cancel{\epsilon_1} + \epsilon_2 - \cancel{\epsilon_1} + \epsilon_2} = \frac{300 + 120}{300 - 120}$$

$$\frac{2\epsilon_1}{2\epsilon_2} = \frac{420}{180}$$

$$\therefore (i) \frac{\epsilon_1}{\epsilon_2} = \frac{7}{3}$$

$$(ii) E_1 - E_2 = 120 \times K$$

$$E_1 - 3/7 E_1 = 120K$$

$$E_1 = 210K$$

$$\text{SO } L \text{ or } E_1 = 210\text{cm}$$

by increasing the length of the wire its resistance can be increased.

OR

$$\text{as } I(1 + 1 + R) = 1 - 3$$

$$\therefore I = \frac{6}{2 + R} \quad \dots(1)$$

$$\text{Now in loop I, } 9 - 6 = 2I$$

$$3 = 2I$$

$$\therefore I = \frac{3}{2} \text{ A}$$

$$\text{Put it in (i) } \therefore R = 2\Omega$$

QB365 - Question Bank Software

23. (a) The constancy of the binding energy in the range $30 < A < 170$ is a consequence of the fact that nuclear force is short ranged.

(b) the radius of nuclei = $R_0 A^{1/3} = R$

$$\text{Volume} = \frac{4}{3} \pi R^3 = \frac{4}{3} \pi R_0^3 A$$

$$\text{Density} = \frac{\text{Mass}}{\text{Volume}} = \frac{\text{mass of nucleon} \times A}{\frac{4}{3} \pi R_0^3 \times A} = \text{constant}$$

24. Two factors that justify modulation...

- (i) For the proper transmission of the signal the size of the antenna should be comparable to the wavelength of the transmitting signal ($\lambda/4$). The message signal is usually has low frequency or high wavelength. For the signal of 20 KHZ an antenna of 15 km is required, that is practically not possible. So we modulate the low frequency message signal with high frequency carrier wave.
- (ii) For effective power radiation the size of the antenna should be comparable to the wavelength of the transmitting signal.

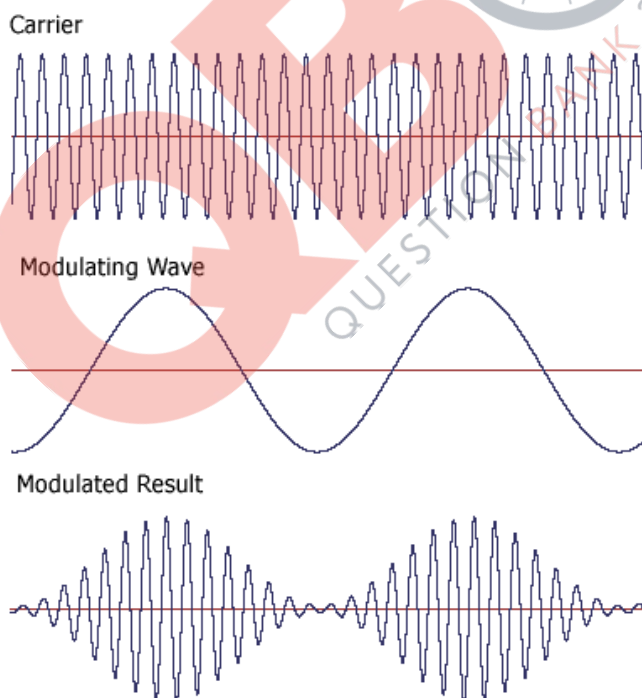

25. Photoelectric effect involves a discrete and abrupt absorption of energy depending on frequency of light rather than intensity, it was postulated by Einstein that light consists of discrete packets or 'quanta' of energy, called photons, which for light of frequency ν have energy $E = h\nu$, with h being Planck's constant, given by $h = 6.626 \times 10^{-34} \text{ Js}$. If the work required to remove an electron from an atom is ϕ , then from conservation of energy, the kinetic energy acquired by the electron on absorbing a photon of frequency ν is given by

$$K = h\nu - \phi \quad (1)$$

QB365 - Question Bank Software

So, if this work is minimum, equal to the work function ϕ_0 , the maximum photoelectron energy will be

$$K_{\max} = h\nu - \phi_0 \quad (2)$$

This is called **Einstein's photoelectric equation**.

1. K_{\max} varies linearly with frequency, and the minimum frequency required will be one at which the emitted electron is at rest, so that

$$h\nu_0 = \phi_0$$

$$\Rightarrow \nu_0 = \frac{\phi_0}{h} \quad \text{which gives the value of the threshold frequency in terms of the work}$$

function of a metal.

Since the energy per photon is fixed, a greater intensity, that is, a greater incident energy per unit area per unit time, would imply more photons, so that the photon picture relates the intensity of light to the number of photons.

2. Since more photons will imply more such discrete absorptions of energy, it is easy to see why above the threshold frequency, the intensity of light is proportionate to the photoelectric current, in turn implying that intensity is directly proportional to the number of photons.

3. It is also easy to see how the stopping potential will be related to the frequency of light

$$eV_0 = h\nu - \phi_0$$

This predicts that V_0 vs ν plot will be a straight line, with intercept $-\frac{\phi_0}{e}$ and slope $\frac{h}{e}$.

This slope was measured by Millikan, and gave the value of Planck's constant, the electron charge already known.

26. (a) If the sources are not coherent, the net intensity at every point will vary. Due to this we will get an average illumination at every point and we do not get fringes.
- (b) For path difference λ , the phase diff.

$$= \frac{2\pi}{\lambda} \times \lambda = 2\pi = 0$$

So $I = 4I_0 \cos^2(0/2)$ (I_0 = intensity of individual wave)

$$I = 4I_0 (\cos^2(\pi))$$

$$I = 4I_0 = K \text{ (as given)}$$

$$\Rightarrow \text{for path diff } \frac{\lambda}{3}, \phi = \frac{2\pi}{\lambda} \times \frac{\lambda}{3} = \frac{2\pi}{3}$$

$$I' = 4I_0 \cos^2\left(\frac{\pi}{3}\right) = K \times \frac{1}{4} = \frac{K}{4}$$

27. Geometrical optics predicts that if parallel light rays are incident on a slit of width a (in an obstruction), then beyond the obstruction, there will be illumination only in a region of width a , the rest being in a region of geometrical shadow.

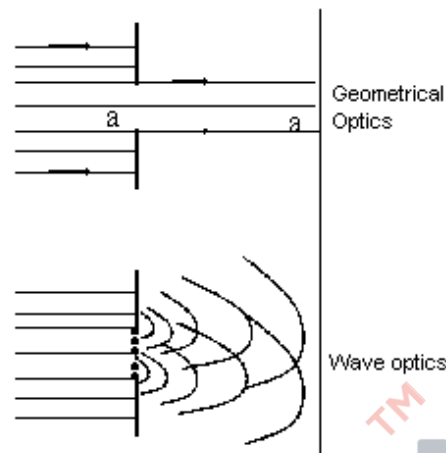

In the first illustration, the obstacle *geometrically* obstructs the light incident on it, letting only the portion, which is geometrically extended beyond it to be illuminated. On the other hand, wave optics predicts that a section of the incident wavefront of width a is allowed to expose the region to the right, and therefore forms the forward wavefront for that region. So, from Huygen's construction, each point on it acts as a source of secondary wavelets, which will interfere to produce the net intensity on the screen. One would expect that there would be a region *within* the geometrical shadow, where this superposition will be non-zero. This leaking of light intensity into the geometrical shadow is called *diffraction*, and is purely a consequence of the wave nature of light.

28. Van de graaf generator is the machine that can build up high voltages upto a few million volts and is, used to accelerate charged particles to high energies.

Working Principle:

Consider a large spherical conducting shell of radius R with uniform charge density and total charge Q .

Then, the potential

$$\phi_Q(r) = \frac{Q}{4\pi\epsilon_0 r}, \text{ for } r \geq R$$

$$\phi_Q(R) = \frac{Q}{4\pi\epsilon_0 R}, \text{ for } r \leq R$$

If a sphere of radius r_0 ($r_0 < R$) carrying total charge q is placed at the center of the larger sphere, potential due to inner sphere is

$$\phi_q(r) = \frac{q}{4\pi\epsilon_0 r} \quad r \geq r_0$$

Therefore, total potential is $\phi(r) = \phi_q(r) + \phi_Q(r)$ and

$$\phi(R) = \frac{1}{4\pi\epsilon_0} \left(\frac{Q}{R} + \frac{q}{R} \right)$$

$$\phi(r_0) = \frac{1}{4\pi\epsilon_0} \left(\frac{Q}{R} + \frac{q}{r_0} \right)$$

$$\therefore \phi(r_0) - \phi(R) = \frac{q}{4\pi\epsilon_0} \left(\frac{1}{r_0} - \frac{1}{R} \right)$$

QB365 - Question Bank Software

Therefore for positive q , whatever Q is, the small sphere is at a higher potential than the shell.

Therefore, if an electric contact is made between the inner sphere and outer shell, charge would flow from the small sphere to the shell. By repeating the process, a large amount of charge can be piled up on the shells with consequent high potential and field. This is the principle behind the working of van de graaff generator.

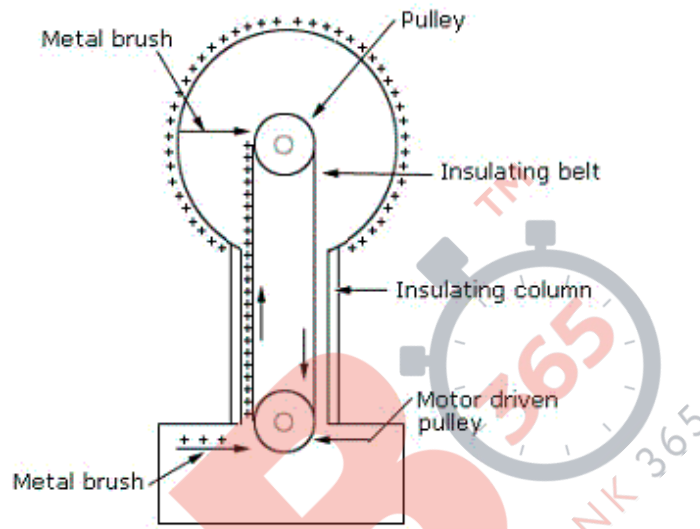

Fig. Schematic diagram of a Van de Graaff generator

Working:

Practically, an insulating column supports a large spherical conducting shell with radius of a few metres. There are two pulleys, one at the center of the shell and the other at the ground. A long narrow belt made of insulating material passes over the pulleys. Charge is sprayed on the belt at the lower pulley by means of a discharge through a metallic brush (with sharp points) connected to a high voltage surface. The belt is moved rapidly by a motor driving the lower pulley. The positive charge thus transferred continuously upward is removed from the belt, again by a metallic brush connected to the shell. In this way, the shell builds up a huge voltage.

The machine can generate high-energy beams in the range of 10 MeV or so. The highest voltage that this device can build up voltages till they match with the break down voltages of the surrounding air.

OR

a. Electric flux $\Delta\phi$ through a surface of area ΔS is defined as the scalar product of the electric field \vec{E} and the area vector $\Delta\vec{S}$.

$$\Delta\phi = \vec{E} \cdot \Delta\vec{S} = E\Delta S \cos\theta$$

where θ is the angle between the directions of \vec{E} and $\Delta\vec{S}$. The magnitude of the area vector $\Delta\vec{S}$ is the same as the area, whereas its direction is along the outer normal to the surface.

SI unit of electric flux is $NC^{-1}m^2$.

b. Electric field due infinite sheet of charge:

Consider a large plane sheet of charge with charge density σCm^{-2} . The electric field lines will emanate normally from this surface.

We want to determine the electric field at a point distant r from this surface.

Gaussian surface

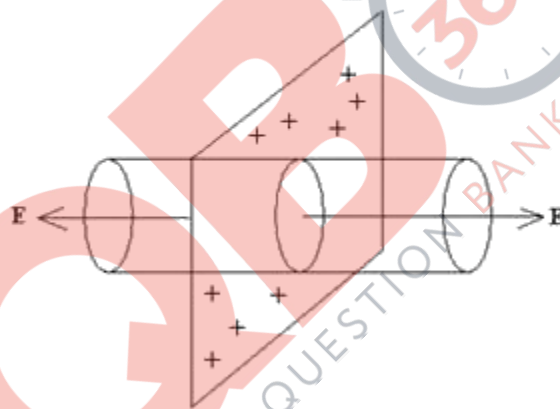

To apply Gauss's Law, Let us consider two circular planes, each of area A, equidistant from and on either sides of the sheet of charge.

Let us join these two surfaces to construct a cylinder, as show. Once again, there are three surfaces. The curved surface is of no consequence because no field lines pass through it. For each of the circular surfaces, \vec{E} is in the same direction as that of the outward normal.

$$\text{Thus, } \phi = \int \vec{E} \cdot d\vec{S} = |\vec{E}| \times A + |\vec{E}| \times A = \frac{|q|}{\epsilon_0} \text{ or, } 2(|\vec{E}| \times A) = \frac{|q|}{\epsilon_0}$$

$$|\vec{E}| = \frac{|q|}{2\epsilon_0 A}$$

But, the net charge enclosed inside the cylinder is given by $|q| = |\sigma| \times A$

$$\text{Hence, } |\vec{E}| = \frac{|q|}{2\epsilon_0 A} = \frac{|\sigma|}{2\epsilon_0}$$

Vectorially, we write $\vec{E} = \frac{\sigma}{2\epsilon_0} \hat{n}$ where \hat{n} is the unit vector in the direction of the outward normal to the sheet of charge.

c) If sheet is (i) positively charged, field will be outward from the sheet and (ii) if the sheet is negatively charged then the field will be in wards, ie directing towards the sheet.

QB365 - Question Bank Software

29. Magnifying power is the ratio of the angle subtended at the eye by the final image to the angle subtended at the eye by the object directly, when both the final image and the object lie at infinite distance from the eye.

$$m = - f_o \text{ (focal length of objective)}/f_e \text{ (focal length of eye piece)}$$

Magnifying power is the ratio of the angle subtended at the eye by the final image to the angle subtended at the eye by the object directly, when both the final image and the object lie at infinite distance from the eye.

$$m = - f_o \text{ (focal length of objective)}/f_e \text{ (focal length of eye piece)}$$

Given:

$$F_o = 150 \text{ cm} = 0.15 \text{ m}$$

$$F_e = 5 \text{ cm} = 0.05 \text{ m}$$

$$O = 100 \text{ m}$$

$$u_a = 3 \text{ km} = 3000 \text{ m}$$

$$v_e = 25 \text{ cm} = 0.25 \text{ m}$$

For Objective lens

Using lens formula

$$\frac{1}{f_o} = \frac{1}{v_o} - \frac{1}{u_o}$$

$$\frac{1}{0.15} = \frac{1}{v_o} + \frac{1}{3000} \text{ (all units in m)}$$

$$\frac{1}{v_o} = \frac{1}{0.15} - \frac{1}{3000} = \frac{20000 - 1}{3000} = \frac{20}{3}$$

$$v_o = +\frac{3}{20} \text{ m}$$

$$m = \frac{v_o}{u_o} = \frac{h'}{h}$$

Solving for h'

$$h' = \frac{1}{200} \text{ m}$$

For eye lens

$$\frac{1}{f_e} = \frac{1}{v_e} - \frac{1}{u_e}$$

$$\text{Solving for } u_e = \frac{-25}{600} \text{ m}$$

$$m = \frac{-v_e}{u_e} = \frac{-h''}{h'}$$

$$h'' = \frac{h'v_e}{u_e}$$

Solving we get

$$h'' = \frac{6}{200}m = 3\text{cm}$$

OR

1. Basically telescope resolves and microscope magnifies.
2. In telescope the objective is larger than eyepiece. Unlike microscope. In telescope the main purpose of objective is to gather more light and to increase the resolving power of telescope.
3. In microscope the objective is to magnify the image so that its magnification can be multiplied by the magnification of the eyepiece.
4. The purpose of eyepiece in both telescope and microscope is same.

$$m = \frac{L}{f_o} \times \frac{D}{f_e}$$

$$30 = \frac{L}{1.25} \times \frac{25}{5}$$

$$L = 7.5\text{Cm}$$

⇒ We know $L = v_o + v_e$

$$7.5 = v_o + v_e \text{ --- (i)}$$

⇒ for objective →

$$\frac{1}{f_o} = \frac{1}{v_o} - \frac{1}{u_o}$$

for eyepiece →

$$\frac{1}{f_e} = \frac{1}{v_e} - \frac{1}{u_e}$$

$$\frac{1}{f_e} = \frac{1}{25} - \frac{1}{v_e} \quad [v_e = D = 25\text{Cm}]$$

for objective

$$\frac{1}{1.25} = \frac{1}{v_o} - \frac{1}{u_o} \text{ --- (2)}$$

for eyepiece

$$\frac{1}{5} = \frac{1}{25} - \frac{1}{v_e} \text{ --- (3)}$$

(b) from (1), (3) become.

$$\frac{1}{5} = \frac{1}{25} - \frac{1}{(7.5 - v_o)} \text{ --- (4)}$$

Now solve (2) & (4) eliminate v_o and get v_o .

30. Diagram of CE amplifier

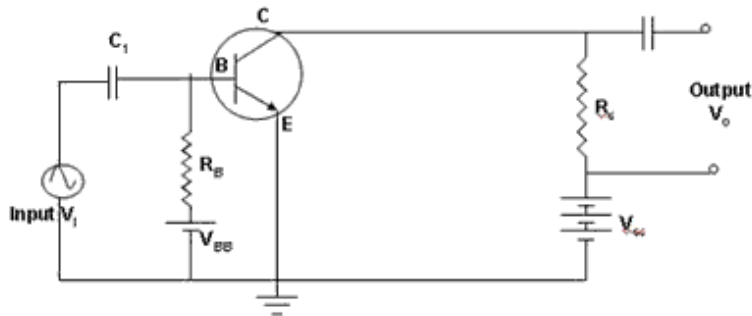

Working:

The input signal is denoted as v_i . This is connected to the input circuit through capacitor C_1 which is used to block the biasing DC voltage from going through the input signal.

The output is taken from the collector resistance R_C . The DC voltage V_{CC} in the output is blocked with the help of the capacitor C_2 . Without the signal, a DC current I_B flows through R_B while I_C is the DC collector current.

If v_i is applied to the input base-emitter side, it will change I_B to $I_B + i_B$, where i_B is due to the signal voltage v_i . The collector current changes to $I_C + i_C$, where i_C is the collector current due to the input signal. The effective input signal is $v_i' = i_B R_B$, and the output voltage is $v_o = -i_C R_C$

So, the voltage amplification is

$$A_v = \frac{v_o}{v_i'} = \frac{i_C R_C}{-i_B R_B}$$

However, since $\beta = \frac{i_C}{i_B}$, therefore

$$A_v = -\beta \frac{R_C}{R_B}$$

Here R_B is input resistance, R_C is the load resistance.

The negative sign represents that output voltage is opposite with phase with the input voltage.

OR

a. The property of a p-n diode to conduct in one direction only can be used to rectify AC voltage, that is, restrict variations to one direction only.

This circuit uses two diodes, and a center-tap transformer, whose secondary is wound into two equal parts. The voltages at any instant at S_1 and S_2 are out of phase with respect to each other. If the voltage at any instant at S_1 is positive, diode D_1 conducts and since voltage at S_2 is negative, D_2 does not conduct.

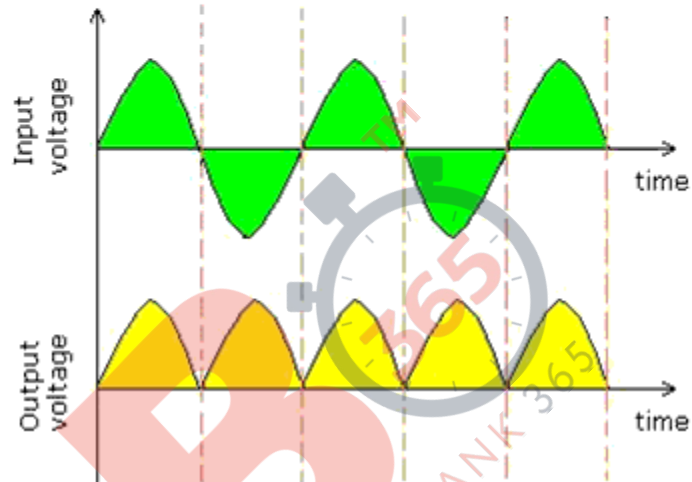
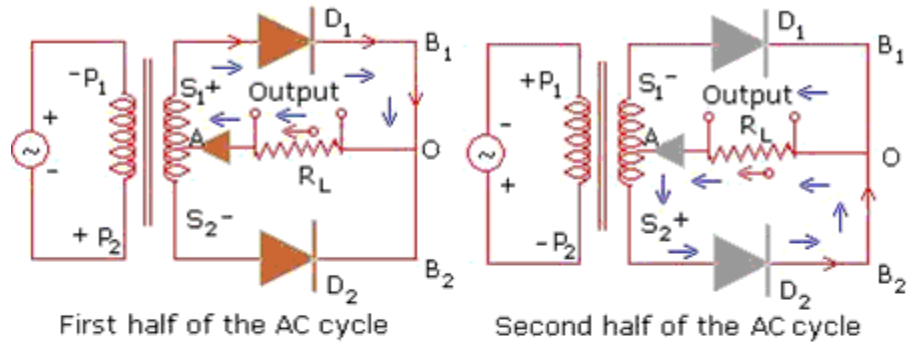

So, during this positive half-cycle, we get an output current and hence voltage across load resistance, as shown above.

If voltage at S_1 becomes negative, only D_2 conducts, and we get an output in the negative half-cycle as well, which is however identical to the output in the positive half-cycle.

b. Given input signals:

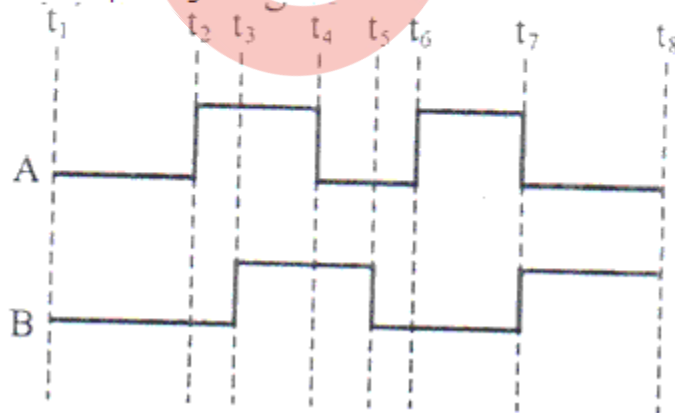

Output of an OR gate:

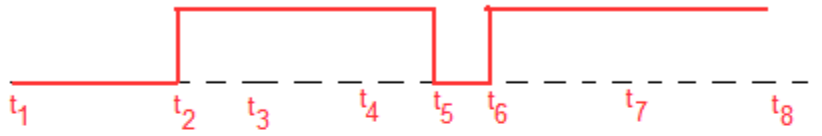

Output of an NAND gate:

