

रोल नं.

Roll No.

--	--	--	--	--	--	--	--

परीक्षार्थी कोड को उत्तर-पुस्तिका के मुख-पृष्ठ पर अवश्य लिखें ।

Candidates must write the Code on the title page of the answer-book.

- कृपया जाँच कर लें कि इस प्रश्न-पत्र में मुद्रित पृष्ठ 16 हैं ।
- प्रश्न-पत्र में दाहिने हाथ की ओर दिए गए कोड नम्बर को छात्र उत्तर-पुस्तिका के मुख-पृष्ठ पर लिखें ।
- कृपया जाँच कर लें कि इस प्रश्न-पत्र में 30 प्रश्न हैं ।
- कृपया प्रश्न का उत्तर लिखना शुरू करने से पहले, प्रश्न का क्रमांक अवश्य लिखें ।
- इस प्रश्न-पत्र को पढ़ने के लिए 15 मिनट का समय दिया गया है । प्रश्न-पत्र का वितरण पूर्वाह्न में 10.15 बजे किया जाएगा । 10.15 बजे से 10.30 बजे तक छात्र केवल प्रश्न-पत्र को पढ़ेंगे और इस अवधि के दौरान वे उत्तर-पुस्तिका पर कोई उत्तर नहीं लिखेंगे ।
- Please check that this question paper contains 16 printed pages.
- Code number given on the right hand side of the question paper should be written on the title page of the answer-book by the candidate.
- Please check that this question paper contains 30 questions.
- **Please write down the Serial Number of the question before attempting it.**
- 15 minutes time has been allotted to read this question paper. The question paper will be distributed at 10.15 a.m. From 10.15 a.m. to 10.30 a.m., the students will read the question paper only and will not write any answer on the answer-book during this period.

भौतिक विज्ञान (सैद्धान्तिक)

PHYSICS (Theory)

निर्धारित समय : 3 घण्टे

Time allowed : 3 hours

अधिकतम अंक : 70

Maximum Marks : 70

QB365 - Question Bank Software

सामान्य निर्देश :

- (i) सभी प्रश्न अनिवार्य हैं ।
- (ii) इस प्रश्न-पत्र में कुल **30** प्रश्न हैं । प्रश्न सं. **1** से **8** तक के प्रश्न अति-लघुउत्तरीय प्रश्न हैं और प्रत्येक एक अंक का है ।
- (iii) प्रश्न सं. **9** से **18** में प्रत्येक प्रश्न दो अंक का है, प्रश्न सं. **19** से **27** में प्रत्येक प्रश्न तीन अंक का है और प्रश्न सं. **28** से **30** में प्रत्येक प्रश्न पाँच अंक का है ।
- (iv) तीन अंकों वाले प्रश्नों में से एक मूल्यपरक प्रश्न है ।
- (v) प्रश्न-पत्र में समग्र पर कोई विकल्प नहीं है । तथापि, दो अंकों वाले एक प्रश्न में, तीन अंकों वाले एक प्रश्न में और पाँच अंकों वाले तीनों प्रश्नों में आन्तरिक चयन प्रदान किया गया है । ऐसे प्रश्नों में आपको दिए गए चयन में से केवल एक प्रश्न ही करना है ।
- (vi) कैलकुलेटर के उपयोग की अनुमति **नहीं** है । तथापि यदि आवश्यक हो तो आप लघुगणकीय सारणियों का प्रयोग कर सकते हैं ।
- (vii) जहाँ आवश्यक हो आप निम्नलिखित भौतिक नियतांकों के मानों का उपयोग कर सकते हैं :

$$c = 3 \times 10^8 \text{ m/s}$$

$$h = 6.63 \times 10^{-34} \text{ Js}$$

$$e = 1.6 \times 10^{-19} \text{ C}$$

$$\mu_0 = 4\pi \times 10^{-7} \text{ T mA}^{-1}$$

$$\frac{1}{4\pi\epsilon_0} = 9 \times 10^9 \text{ N m}^2 \text{ C}^{-2}$$

$$m_e = 9.1 \times 10^{-31} \text{ kg}$$

General Instructions :

- (i) *All questions are compulsory.*
- (ii) *There are **30** questions in total. Questions No. **1** to **8** are very short answer type questions and carry **one** mark each.*
- (iii) *Questions No. **9** to **18** carry **two** marks each, questions no. **19** to **27** carry **three** marks each and questions no. **28** to **30** carry **five** marks each.*
- (iv) *One of the questions carrying three marks weightage is value based question.*

QB365 - Question Bank Software

- (v) *There is no overall choice. However, an internal choice has been provided in one question of two marks, one question of three marks and all three questions of five marks each weightage. You have to attempt only one of the choices in such questions.*
- (vi) *Use of calculators is **not** permitted. However, you may use log tables if necessary.*
- (vii) *You may use the following values of physical constants wherever necessary :*

$$c = 3 \times 10^8 \text{ m/s}$$

$$h = 6.63 \times 10^{-34} \text{ Js}$$

$$e = 1.6 \times 10^{-19} \text{ C}$$

$$\mu_0 = 4\pi \times 10^{-7} \text{ T mA}^{-1}$$

$$\frac{1}{4\pi\epsilon_0} = 9 \times 10^9 \text{ N m}^2 \text{ C}^{-2}$$

$$m_e = 9.1 \times 10^{-31} \text{ kg}$$

1. पाठक से दूर लूप (पाश) के तल के अभिलम्बवत निर्दिष्ट चुम्बकीय क्षेत्र में चित्र में दर्शाए अनुसार लचीले तार की अनियमित आकृति, abcd को रखने पर वह वृत्तीय आकार में बदल जाती है। तार में उत्पन्न प्रेरित धारा की दिशा का अनुमान लगाइए।

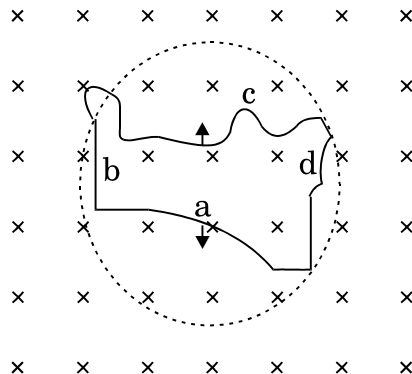

QB365 - Question Bank Software

A flexible wire of irregular shape, abcd, as shown in the figure, turns into a circular shape when placed in a region of magnetic field which is directed normal to the plane of the loop away from the reader. Predict the direction of the induced current in the wire.

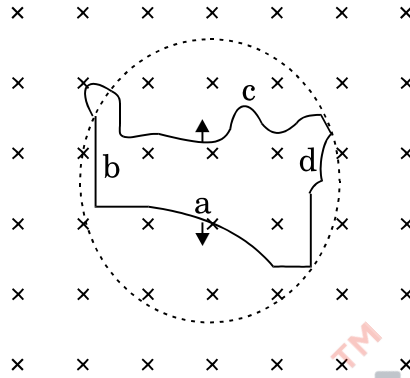

2. किसी आवेशित चालक के पृष्ठ के प्रत्येक बिन्दु पर स्थिर-वैद्युत क्षेत्र को पृष्ठ के अभिलम्बवत क्यों होना चाहिए ? कारण दीजिए । 1

Why must electrostatic field at the surface of a charged conductor be normal to the surface at every point ? Give reason.

3. एक टेसला की परिभाषा, किसी चुम्बकीय क्षेत्र \vec{B} में \vec{v} वेग से गतिमान आवेश 'q' के कण पर कार्यरत चुम्बकीय बल के लिए व्यंजक का उपयोग करते हुए, कीजिए । 1

Define one tesla using the expression for the magnetic force acting on a particle of charge 'q' moving with velocity \vec{v} in a magnetic field \vec{B} .

4. β^- क्षय तथा β^+ क्षय दोनों ही प्रक्रियाओं में, नाभिक की द्रव्यमान संख्या समान रहती है जबकि β^- क्षय में परमाणु संख्या Z में एक की वृद्धि तथा β^+ क्षय में एक की कमी हो जाती है । कारण सहित व्याख्या कीजिए । 1

In both β^- and β^+ decay processes, the mass number of a nucleus remains same whereas the atomic number Z increases by one in β^- decay and decreases by one in β^+ decay. Explain, giving reason.

5. निम्नलिखित विद्युत्-चुम्बकीय तरंगों को उनकी आवृत्तियों के बढ़ते क्रम में व्यवस्थित कीजिए : 1
 γ -किरणें, सूक्ष्म तरंगें, अवरक्त किरणें और पराबैंगनी किरणें ।

Arrange the following electromagnetic waves in order of increasing frequency :

γ -rays, microwaves, infrared rays and ultraviolet rays.

6. आरेख में किसी धनावेश पर क्षेत्र रेखाएँ दर्शायी गयी हैं। किसी लघु धनावेश को Q से P तक गति कराने में क्षेत्र द्वारा किया गया कार्य धनात्मक है अथवा ऋणात्मक ? कारण दीजिए।

1

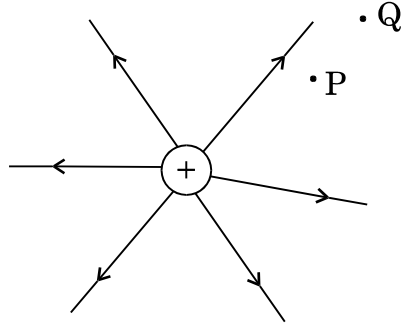
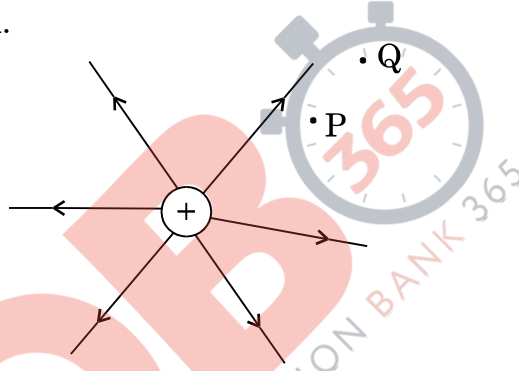

Figure shows the field lines on a positive charge. Is the work done by the field in moving a small positive charge from Q to P positive or negative ? Give reason.



7. प्रकाश-विद्युत् प्रभाव में, किसी प्रकाश-सुग्राही पृष्ठ पर आपतित एकवर्णी विकिरण की तीव्रता में वृद्धि होने पर प्रकाश-विद्युत् धारा में वृद्धि क्यों होनी चाहिए ? व्याख्या कीजिए।

1

In photoelectric effect, why should the photoelectric current increase as the intensity of monochromatic radiation incident on a photosensitive surface is increased ? Explain.

8. चित्र में दर्शाए अनुसार किसी पारदर्शी गोले, जिसका केन्द्र C है, पर कोई प्रकाश किरण आपतित है। गोले से निर्गत किरण रेखा AB के समान्तर है। यदि गोले के पदार्थ का अपवर्तनांक $\sqrt{3}$ है, तो बिन्दु A पर अपवर्तन कोण ज्ञात कीजिए।

1

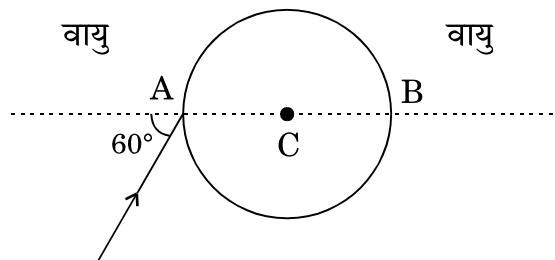

QB365 - Question Bank Software

A ray of light falls on a transparent sphere with centre C as shown in the figure. The ray emerges from the sphere parallel to the line AB . Find the angle of refraction at A if refractive index of the material of the sphere is $\sqrt{3}$.

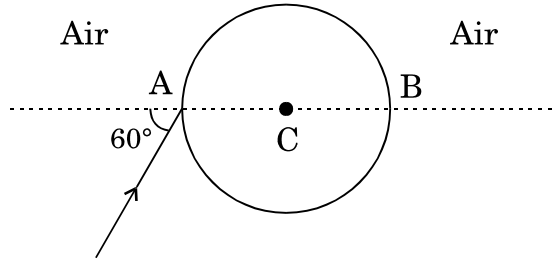

9. दो अति लघु सर्वसम वृत्तीय लूप (पाश), (1) और (2), जिनसे समान धाराएँ I प्रवाहित हो रही हैं, चित्र में दर्शाए अनुसार एक-दूसरे के ज्यामितीय अक्षों को लम्बवत् रखते हुए ऊर्ध्वाधर (कागज़ के तल के सापेक्ष) रखे गए हैं। बिन्दु O पर उत्पन्न नेट चुम्बकीय क्षेत्र का परिमाण और दिशा ज्ञात कीजिए।

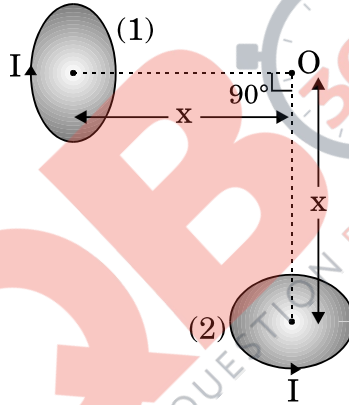

Two very small identical circular loops, (1) and (2), carrying equal currents I are placed vertically (with respect to the plane of the paper) with their geometrical axes perpendicular to each other as shown in the figure. Find the magnitude and direction of the net magnetic field produced at the point O .

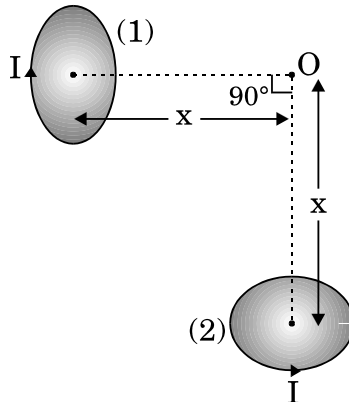

10. आदर्श संधारित्र के प्रत्यावर्ती धारा (ac) परिपथ के लिए यह दर्शाइए कि परिपथ में प्रवाहित धारा कला में वोल्टता से $\pi/2$ आगे रहती है । 2

Show that the current leads the voltage in phase by $\pi/2$ in an ac circuit containing an ideal capacitor.

11. अनुचुम्बकीय पदार्थ और प्रतिचुम्बकीय पदार्थ के बीच विभेदन करने वाले दो बिन्दु लिखिए । 2

Give two points to distinguish between a paramagnetic and a diamagnetic substance.

12. दर्शाए गए परिपथ में संधारित्र पर आवेश ज्ञात कीजिए । 2

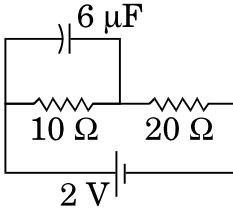

Find the charge on the capacitor as shown in the circuit.

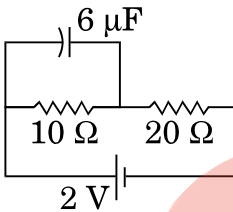

13. चित्र में दर्शाए गए परिपथ द्वारा निरूपित तुल्य गेट को पहचानिए । इसका तर्क प्रतीक खींचिए और सत्यमान सारणी लिखिए । 2

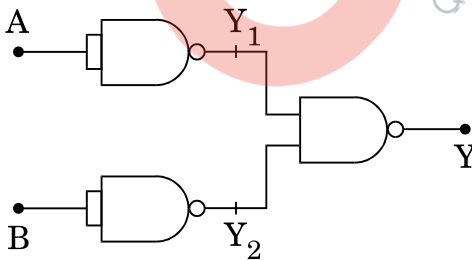

Identify the equivalent gate represented by the circuit shown in the figure. Draw its logic symbol and write the truth table.

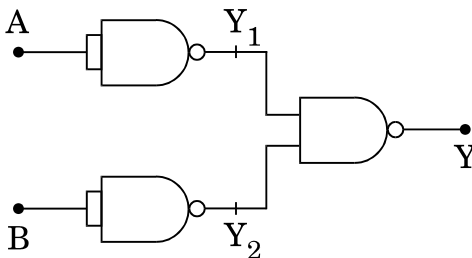

14. आरेख में प्रिज्म से किसी प्रकार की किरण को गुजरते हुए दर्शाया गया है। यदि अपवर्तित किरण QR आधार BC के समान्तर है, तो यह दर्शाइए कि (i) $r_1 = r_2 = A/2$, (ii) न्यूनतम विचलन कोण, $D_m = 2i - A$.

2

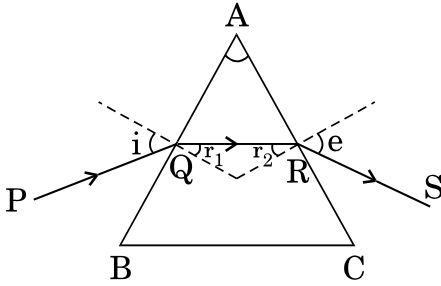
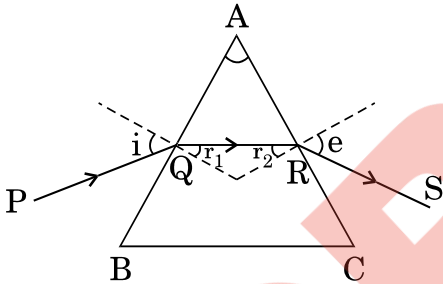

Figure shows a ray of light passing through a prism. If the refracted ray QR is parallel to the base BC, show that (i) $r_1 = r_2 = A/2$, (ii) angle of minimum deviation, $D_m = 2i - A$.



15. माडुलन पद की परिभाषा लिखिए। AM सिग्नल प्राप्त करने के लिए सरल माडुलक का ब्लॉक आरेख खींचिए।

2

Define the term modulation. Draw a block diagram of a simple modulator for obtaining AM signal.

16. (a) दोलनी आवेश किस प्रकार विद्युत्-चुम्बकीय तरंगों उत्पन्न करता है ?
 (b) + z-दिशा के अनुदिश संचरित किसी विद्युत्-चुम्बकीय तरंग के दोलीय विद्युत् और चुम्बकीय क्षेत्रों को दर्शाने वाला व्यवस्था आरेख खींचिए।

2

- (a) How does oscillating charge produce electromagnetic waves ?
 (b) Sketch a schematic diagram depicting oscillating electric and magnetic fields of an em wave propagating along + z-direction.

17. p-प्रकार के अर्धचालक और n-प्रकार के अर्धचालक के ताप $T > 0$ K पर ऊर्जा बैंड आरेख खींचिए। इन आरेखों पर, दाता और ग्राही ऊर्जा स्तरों को उनकी ऊर्जाओं सहित अंकित कीजिए।

2

अथवा

ऊर्जा बैंड आरेखों के आधार पर किसी धातु और किसी विद्युत्रोधी के बीच विभेदन कीजिए।

2

QB365 - Question Bank Software

Draw energy band diagrams of an n-type and p-type semiconductor at temperature $T > 0$ K. Mark the donor and acceptor energy levels with their energies.

OR

Distinguish between a metal and an insulator on the basis of energy band diagrams.

18. किसी श्रेणीबद्ध LCR परिपथ में, वह स्थितियाँ प्राप्त कीजिए जिनमें (i) परिपथ की प्रतिबाधा न्यूनतम होती है, और (ii) परिपथ में वाटहीन धारा प्रवाहित होती है । 2

In a series LCR circuit, obtain the conditions under which (i) the impedance of the circuit is minimum, and (ii) wattless current flows in the circuit.

19. दो कुण्डलियों, जिनके स्वप्रेरकत्व $L_1 = 16$ mH और $L_2 = 12$ mH हैं, से प्रवाहित विद्युत् धाराओं में समान दर से वृद्धि हो रही है । यदि दोनों कुण्डलियों को प्रदान की जाने वाली शक्ति समान है, तो किसी दिए गए क्षण पर इन दोनों कुण्डलियों में (i) प्रेरित वोल्टताओं, (ii) धाराओं और (iii) संचित ऊर्जाओं का अनुपात ज्ञात कीजिए । 3

The currents flowing in the two coils of self-inductance $L_1 = 16$ mH and $L_2 = 12$ mH are increasing at the same rate. If the power supplied to the two coils are equal, find the ratio of (i) induced voltages, (ii) the currents and (iii) the energies stored in the two coils at a given instant.

20. (a) कोई बिन्दुकित आवेश (+Q) किसी अनावेशित धातु की चादर के समीप स्थित है । आवेश और धातु की चादर के बीच विद्युत्-क्षेत्र रेखाएँ खींचिए ।
(b) दो पतले समान्तर अनन्त तल शीट जिनके आवेश घनत्व σ_1 तथा σ_2 ($\sigma_1 > \sigma_2$) हैं, चित्र में दर्शाए गए हैं । II और III द्वारा अंकित क्षेत्रों में नेट विद्युत्-क्षेत्रों के परिमाण और दिशाएँ लिखिए । 3

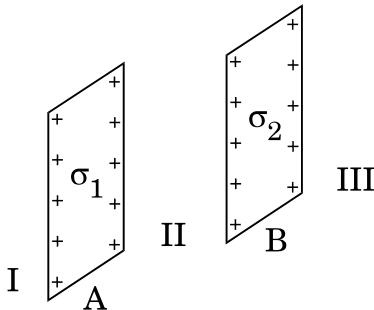

QB365 - Question Bank Software

- (a) A point charge (+Q) is kept in the vicinity of uncharged conducting plate. Sketch electric field lines between the charge and the plate.
- (b) Two infinitely large plane thin parallel sheets having surface charge densities σ_1 and σ_2 ($\sigma_1 > \sigma_2$) are shown in the figure. Write the magnitudes and directions of the net fields in the regions marked I and III.

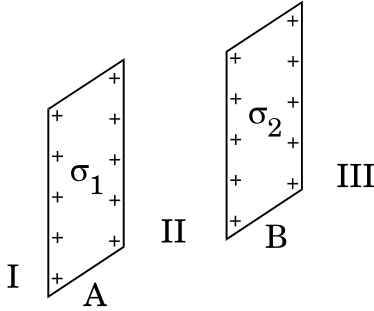

21. (a) दो लम्बे सीधे समान्तर चालकों 'a' और 'b', जिनमें स्थायी धाराएँ I_a और I_b प्रवाहित हो रही हैं, के बीच पृथक्कन दूरी d है। चालक 'a' द्वारा चालक 'b' के अनुदिश बिन्दुओं पर उत्पन्न चुम्बकीय क्षेत्र का परिमाण और दिशा लिखिए। यदि इन चालकों में प्रवाहित धाराओं की दिशा समान है, तो दोनों चालकों के बीच बल का परिमाण और प्रकृति क्या है ?
- (b) आरेख की सहायता से दर्शाइए कि जब इन चालकों से धाराएँ विपरीत दिशाओं में प्रवाहित होती हैं, तो दोनों चालकों के बीच बल में किस प्रकार परिवर्तन होगा।
- (a) Two long straight parallel conductors 'a' and 'b', carrying steady currents I_a and I_b are separated by a distance d . Write the magnitude and direction of the magnetic field produced by the conductor 'a' at the points along the conductor 'b'. If the currents are flowing in the same direction, what is the nature and magnitude of the force between the two conductors ?
- (b) Show with the help of a diagram how the force between the two conductors would change when the currents in them flow in the opposite directions.

22. उचित आरेखों की सहायता से संचरण की (i) आकाश तरंग और (ii) व्योम तरंग विधियों का संक्षेप में वर्णन कीजिए। संचरण की इन विधियों में प्रयुक्त तरंगों की आवृत्तियों के परिसर का उल्लेख भी कीजिए।

Describe briefly, by drawing suitable diagrams, the (i) sky wave and (ii) space wave modes of propagation. Mention the frequency range of the waves in these modes of propagation.

23. (a) संक्षेप में वर्णन कीजिए कि किस प्रकार डैविसन तथा जर्मेर प्रयोग द्वारा इलेक्ट्रॉनों की तरंग प्रकृति का निर्दर्शन किया गया ।
- (b) किसी इलेक्ट्रॉन को उसकी विरामावस्था से किसी विभव V द्वारा त्वरित किया जाता है । इससे सम्बद्ध दे-ब्रॉग्ली तरंगदैर्घ्य के लिए व्यंजक प्राप्त कीजिए ।
- (a) Describe briefly how Davisson – Germer experiment demonstrated the wave nature of electrons.
- (b) An electron is accelerated from rest through a potential V . Obtain the expression for the de-Broglie wavelength associated with it.

3

24. कक्षा X की छात्रा पूजा ने अपनी माताजी को खुले में कपड़े धोते समय, साबुन के रंगीन बुलबुले देखे और उसे यह जानने की जिज्ञासा हुई कि साबुन के बुलबुले रंगीन क्यों प्रतीत होते हैं । सायंकाल जब उसके पिताजी, जो पेशे से इंजीनियर हैं, घर आए तो उसने इसी विषय में उनसे प्रश्न पूछा । उसके पिताजी ने उसे भौतिकी की उस मूल परिघटना से अवगत कराया जिसके कारण साबुन के बुलबुले रंगीन दिखाई देते हैं ।

(a) आपके विचार से पूजा और उसके पिताजी किन मूल्यों को दर्शाते हैं ?

(b) साबुन के रंगीन बुलबुले बनने में सम्मिलित प्रकाशिक परिघटना का उल्लेख कीजिए ।

3

When Puja, a student of 10th class, watched her mother washing clothes in the open, she observed coloured soap bubbles and was curious to know why the soap bubbles appear coloured. In the evening when her father, an engineer by profession, came home, she asked him this question. Her father explained to her the basic phenomenon of physics due to which the soap bubbles appear coloured.

(a) What according to you are the values displayed by Puja and her father ?

(b) State the phenomenon of light involved in the formation of coloured soap bubbles.

25. (a) ज़ेनर डायोड का संविरचन (निर्माण) संधि के p- तथा n- दोनों फलकों को अत्यधिक अपमिश्रित करके क्यों किया जाता है ?
- (b) वोल्टता नियंत्रक के रूप में ज़ेनर डायोड के उपयोग को दर्शाने के लिए परिपथ आरेख खींचकर संक्षेप में इसकी कार्यविधि की व्याख्या कीजिए ।

3

अथवा

(a) फ़ोटोडायोड का निर्माण किस प्रकार किया जाता है ?

(b) इसकी कार्यविधि का संक्षेप में वर्णन कीजिए । दो विभिन्न प्रदीपन-तीव्रताओं के लिए इसके $V - I$ अभिलाक्षणिक खींचिए ।

3

QB365 - Question Bank Software

- (a) Why is zener diode fabricated by heavily doping both p- and n-sides of the junction ?
- (b) Draw the circuit diagram of zener diode as a voltage regulator and briefly explain its working.

OR

- (a) How is a photodiode fabricated ?
- (b) Briefly explain its working. Draw its V – I characteristics for two different intensities of illumination.

- 26.**
- (i) अध्रुवित प्रकाश और रैखिकतः ध्रुवित प्रकाश के बीच विभेदन कीजिए ।
 - (ii) पोलैरोइड किस प्रकार बनाया जाता है ? यह रैखिकतः ध्रुवित प्रकाश किस प्रकार उत्पन्न करता है ?
 - (iii) संक्षेप में व्याख्या कीजिए कि वायुमण्डलीय कणों से प्रकीर्णित होकर सूर्य का प्रकाश किस प्रकार ध्रुवित हो जाता है ।
- (i) Distinguish between unpolarised and linearly polarised light.
 - (ii) What does a polaroid consist of ? How does it produce a linearly polarised light ?
 - (iii) Explain briefly how sunlight is polarised by scattering through atmospheric particles.

3

- 27.** किसी समान्तर पट्टिका संधारित्र में, जिसकी पट्टिकाओं के बीच वायु है, की प्रत्येक पट्टिका का क्षेत्रफल $6 \times 10^{-3} \text{ m}^2$ और पट्टिकाओं के बीच पृथक्कन 3 mm है ।
- (i) इस संधारित्र की धारिता परिकल्पित कीजिए ।
 - (ii) यदि इस संधारित्र को 100 V आपूर्ति से संयोजित किया जाए, तो प्रत्येक पट्टिका पर कितना आवेश होगा ?
 - (iii) यदि वोल्टता आपूर्ति को संयोजित रखते हुए संधारित्र की पट्टिकाओं के बीच $K = 6$ की अभ्रक की 3 mm मोटी चादर रख दी जाए, तो पट्टिकाओं पर आवेश किस प्रकार प्रभावित होगा ?

3

In a parallel plate capacitor with air between the plates, each plate has an area of $6 \times 10^{-3} \text{ m}^2$ and the separation between the plates is 3 mm.

- (i) Calculate the capacitance of the capacitor.
- (ii) If this capacitor is connected to 100 V supply, what would be the charge on each plate ?
- (iii) How would charge on the plates be affected, if a 3 mm thick mica sheet of $K = 6$ is inserted between the plates while the voltage supply remains connected ?

QB365 - Question Bank Software

28. (a) बोर के अभिगृहीतों का उपयोग करके, हाइड्रोजन परमाणु की स्थिर अवस्थाओं में इलेक्ट्रॉन की कुल ऊर्जा के लिए व्यंजक व्युत्पन्न कीजिए ।
- (b) रिडबर्ग सूत्र का उपयोग करके, लाइमेन श्रेणी और बामर श्रेणी के पहले सदस्य की स्पेक्ट्रमी रेखाओं की तरंगदैर्घ्यों को परिकलित कीजिए ।

5

अथवा

- (a) (i) अर्ध-आयु ($T_{1/2}$) और (ii) औसत आयु (τ) पदों की परिभाषा लिखिए । इनके क्षय स्थिरांक (λ) से संबंध ज्ञात कीजिए ।

- (b) किसी रेडियोएक्टिव नाभिक का क्षय स्थिरांक $\lambda = 0.3465$ (दिन) $^{-1}$ है । आरम्भिक मात्रा से 75% तक क्षयित होने में इसके नाभिक को कितना समय लगेगा ?

5

- (a) Using Bohr's postulates, derive the expression for the total energy of the electron in the stationary states of the hydrogen atom.
- (b) Using Rydberg formula, calculate the wavelengths of the spectral lines of the first member of the Lyman series and of the Balmer series.

OR

- (a) Define the terms (i) half-life ($T_{1/2}$) and (ii) average life (τ). Find out their relationships with the decay constant (λ).

- (b) A radioactive nucleus has a decay constant $\lambda = 0.3465$ (day) $^{-1}$. How long would it take the nucleus to decay to 75% of its initial amount ?

29. (a) विभवमापी का सिद्धान्त लिखिए । विभव प्रवणता की परिभाषा लिखिए । विभवमापी तार की प्रतिरोधकता के पदों में विभव प्रवणता के लिए व्यंजक प्राप्त कीजिए ।

QB365 - Question Bank Software

- (b) चित्र में नियत विभव प्रवणता का कोई लम्बा विभवमापी तार AB दर्शाया गया है। ϵ_1 तथा ϵ_2 विद्युत्-वाहक बलों के दो प्राथमिक सेलों, जिन्हें दर्शाए अनुसार संयोजित किया गया है, के लिए शून्य विक्षेप स्थितियाँ, सिरे A से दूरियों $l_1 = 120 \text{ cm}$ तथा $l_2 = 300 \text{ cm}$ पर प्राप्त होती हैं। (i) ϵ_1/ϵ_2 और (ii) केवल ϵ_1 सेल के लिए शून्य विक्षेप स्थिति ज्ञात कीजिए।

5

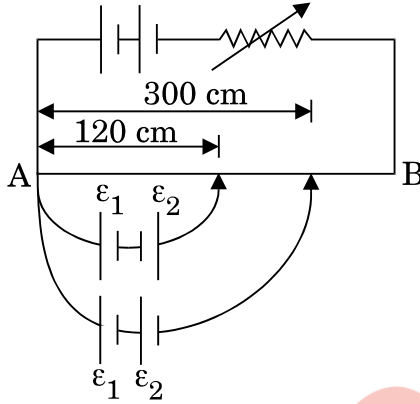

अथवा

- (a) किसी चालक में आवेश वाहकों के 'अपवाह वेग' पद की परिभाषा लिखिए। विश्रांति काल के पदों में धारा घनत्व के लिए व्यंजक प्राप्त कीजिए।
- (b) 100 V की कोई बैटरी दर्शाए गए विद्युत् नेटवर्क में संयोजित है। यदि 2Ω प्रतिरोधक में उपभुक्त शक्ति 200 W है, तो 5Ω प्रतिरोधक में शक्ति-क्षय निर्धारित कीजिए।

5

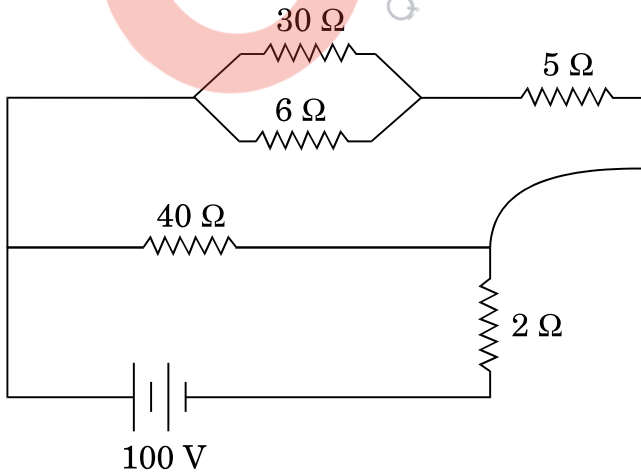

- (a) State the principle of a potentiometer. Define potential gradient. Obtain an expression for potential gradient in terms of resistivity of the potentiometer wire.

QB365 - Question Bank Software

- (b) Figure shows a long potentiometer wire AB having a constant potential gradient. The null points for the two primary cells of emfs ε_1 and ε_2 connected in the manner shown are obtained at a distance of $l_1 = 120$ cm and $l_2 = 300$ cm from the end A. Determine (i) $\varepsilon_1/\varepsilon_2$ and (ii) position of null point for the cell ε_1 only.

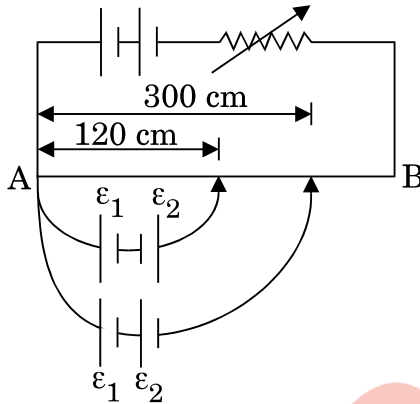

OR

- (a) Define the term 'drift velocity' of charge carriers in a conductor. Obtain the expression for the current density in terms of relaxation time.
- (b) A 100 V battery is connected to the electric network as shown. If the power consumed in the 2Ω resistor is 200 W, determine the power dissipated in the 5Ω resistor.

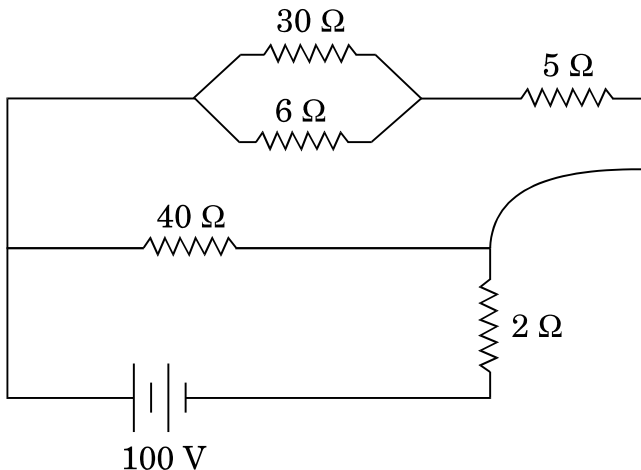

30. (a) किसी दूरस्थ बिम्ब का प्रतिबिम्ब बनाने के लिए खगोलीय दूरदर्शक का नामांकित किरण आरेख खींचिए। किसी दूरदर्शक की उच्च आवर्धन क्षमता और उच्च विभेदन क्षमता के लिए अभिदृश्यक तथा नेत्रिका लेंसों का चयन करते समय आवश्यक ध्यान देने योग्य प्रमुख विचारों का उल्लेख कीजिए।
- (b) किसी संयुक्त सूक्ष्मदर्शी के अभिदृश्यक की फोकस दूरी 1.25 cm और नेत्रिका की फोकस दूरी 5 cm है। कोई लघु बिम्ब इसके अभिदृश्यक से 2.5 cm दूरी पर रखा गया है। यदि अन्तिम प्रतिबिम्ब अनन्त पर बनता है, तो अभिदृश्यक और नेत्रिका के बीच की दूरी ज्ञात कीजिए।

5

अथवा

- (a) यंग के द्वि-झिरी प्रयोग में प्राप्त व्यतिकरण फ्रिन्जों और पतली एकल झिरी के कारण प्राप्त विवर्तन पैटर्न के बीच विभेदन करने योग्य तीन अभिलाक्षणिक विशेषताएँ लिखिए।
- (b) 500 nm तरंगदैर्घ्य का कोई समान्तर प्रकाश पुन्ज किसी पतली झिरी पर आपतन करता है और परिणामी विवर्तन पैटर्न 1 m दूरी पर स्थित पर्दे पर दिखाई देता है। प्रेक्षण करने पर यह पाया जाता है कि प्रथम निम्निष्ठ केन्द्र से 2.5 mm की दूरी पर है। झिरी की चौड़ाई ज्ञात कीजिए।
- (a) Draw a labelled ray diagram of an astronomical telescope to show the image formation of a distant object. Write the main considerations required in selecting the objective and eyepiece lenses in order to have large magnifying power and high resolution of the telescope.
- (b) A compound microscope has an objective of focal length 1.25 cm and eyepiece of focal length 5 cm. A small object is kept at 2.5 cm from the objective. If the final image formed is at infinity, find the distance between the objective and the eyepiece.

5

OR

- (a) Write three characteristic features to distinguish between the interference fringes in Young's double slit experiment and the diffraction pattern obtained due to a narrow single slit.
- (b) A parallel beam of light of wavelength 500 nm falls on a narrow slit and the resulting diffraction pattern is observed on a screen 1 m away. It is observed that the first minimum is a distance of 2.5 mm away from the centre. Find the width of the slit.

**MARKING SCHEME
SET 55/2/1**

Q. No.	Expected Answer / Value Points	Marks	Total Marks				
1.	Anticlockwise / a d c b a	1	1				
2.	It is an equipotential surface, [alternatively if the electric field were not normal to the surface, then it would have a component along the surface which would cause work to be done in moving a charge on an equipotential surface.]	1	1				
3.	When a charge of 1C, moving with velocity 1 m/s, normal to the magnetic field, experiences a force of 1N, magnetic field is said to be one tesla.	1	1				
4.	It is due to conversion of neutron to proton or proton to neutron inside the nucleus. Alternatively:- ${}^A_ZX \rightarrow \beta^- + {}^A_{Z+1}Y + \bar{\nu}$ ${}^A_ZX \rightarrow \beta^+ + {}^A_{Z-1}Y + \bar{\nu}$	1	1				
5.	Microwave < Infrared < Ultraviolet < γ - rays	1	1				
6.	Negative; As charge is displaced against the force exerted by the field.	$\frac{1}{2}$ $\frac{1}{2}$	1				
7.	Increase in intensity of the incident radiation corresponds to an increase in the number of incidents photons, resulting in the an increase in the number of photo electrons emitted.	$\frac{1}{2}$ $\frac{1}{2}$	1				
8.	$\frac{\sin i}{\sin r} = \mu$ $\frac{\sin 60^\circ}{\sin r} = \sqrt{3}$ gives $r = 30^\circ$ (Note: if a student just gives the answer 30°, award this 1 mark.)	$\frac{1}{2}$ $\frac{1}{2}$	1				
9.	<table border="1" style="width: 100%; border-collapse: collapse;"> <tr> <td>Calculation of resultant magnetic field</td> <td align="right">1 $\frac{1}{2}$</td> </tr> <tr> <td>Direction</td> <td align="right">$\frac{1}{2}$</td> </tr> </table> $B = \frac{\mu_0 I r^2}{2(r^2 + x^2)^{3/2}}$ Net field at O, $B_0 = \sqrt{2}B = \frac{\sqrt{2}\mu_0 I r^2}{2(r^2 + x^2)^{3/2}}$	Calculation of resultant magnetic field	1 $\frac{1}{2}$	Direction	$\frac{1}{2}$	 $\frac{1}{2}$ $\frac{1}{2}$	
Calculation of resultant magnetic field	1 $\frac{1}{2}$						
Direction	$\frac{1}{2}$						

QB365 - Question Bank Software

	<p>For <u>small</u> loop ($r \ll x$), $B_0 = \frac{\sqrt{2}\mu_0 I}{2x^3}$</p> <p>Direction of B_0 is at 45° with the axis of any of the two loops.</p>	<p>$\frac{1}{2}$</p> <p>$\frac{1}{2}$</p>	<p>2</p>														
10.	<div style="border: 1px solid black; padding: 5px; margin-bottom: 10px;"> <p>Derivation of current flowing through capacitor 1 $\frac{1}{2}$ To show current leads voltage $\frac{1}{2}$</p> </div> <p>If $V = V_0 \sin \omega t$ $q = CV = CV_0 \sin \omega t$</p> <p>$I = \frac{dq}{dt} = \omega CV_0 \cos \omega t$</p> <p>Or $I = \omega CV_0 \sin(\omega t + \frac{\pi}{2})$ So, the current leads the applied voltage, in phase by $\frac{\pi}{2}$.</p>	<p>$\frac{1}{2}$</p> <p>$\frac{1}{2}$</p> <p>$\frac{1}{2}$</p> <p>$\frac{1}{2}$</p>	2														
11.	<div style="border: 1px solid black; padding: 5px; margin-bottom: 10px;"> <p>Two points of difference 1 + 1</p> </div> <table border="1" style="width: 100%; border-collapse: collapse; margin-bottom: 10px;"> <thead> <tr> <th style="width: 50%; text-align: center;">Diamagnetic</th> <th style="width: 50%; text-align: center;">Paramagnetic</th> </tr> </thead> <tbody> <tr> <td>1. Weakly repelled by external magnetic field.</td> <td>1. Weakly attracted by magnetic field.</td> </tr> <tr> <td>2. Align perpendicular to the field</td> <td>2. Align parallel to the field.</td> </tr> <tr> <td>3. Move from stronger to weaker region.</td> <td>3. Move from weaker to stronger region.</td> </tr> <tr> <td>4. Not affected by temperature</td> <td>4. Affected by temperature.</td> </tr> <tr> <td>5. Susceptibility < 0</td> <td>5. Susceptibility > 0</td> </tr> <tr> <td>6. Permeability $\mu_r < 1$</td> <td>6. Permeability $\mu_r > 1$</td> </tr> </tbody> </table> <p>(Any two points of difference)</p>	Diamagnetic	Paramagnetic	1. Weakly repelled by external magnetic field.	1. Weakly attracted by magnetic field.	2. Align perpendicular to the field	2. Align parallel to the field.	3. Move from stronger to weaker region.	3. Move from weaker to stronger region.	4. Not affected by temperature	4. Affected by temperature.	5. Susceptibility < 0	5. Susceptibility > 0	6. Permeability $\mu_r < 1$	6. Permeability $\mu_r > 1$	1+1	2
Diamagnetic	Paramagnetic																
1. Weakly repelled by external magnetic field.	1. Weakly attracted by magnetic field.																
2. Align perpendicular to the field	2. Align parallel to the field.																
3. Move from stronger to weaker region.	3. Move from weaker to stronger region.																
4. Not affected by temperature	4. Affected by temperature.																
5. Susceptibility < 0	5. Susceptibility > 0																
6. Permeability $\mu_r < 1$	6. Permeability $\mu_r > 1$																
12.	<div style="border: 1px solid black; padding: 5px; margin-bottom: 10px;"> <p>Calculation of charge 2</p> </div> <p>$I = \frac{2V}{30\Omega} = \frac{1}{15} \text{ A}$</p> <p>$V = IR = \frac{2}{3} \text{ V}$</p> <p>$q = CV = 4\mu\text{C}$</p>	<p>$\frac{1}{2}$</p> <p>$\frac{1}{2}$</p>	<p>$\frac{1}{2} + \frac{1}{2}$</p> <p>2</p>														

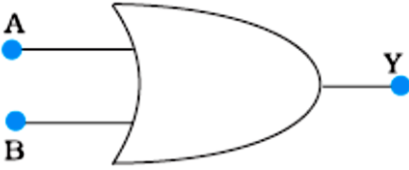
13.	<div style="border: 1px solid black; padding: 5px; margin-bottom: 10px;"> <table style="width: 100%; border-collapse: collapse;"> <tr> <td style="padding: 2px;">Identification of equivalent gate</td> <td style="text-align: right; padding: 2px;">1</td> </tr> <tr> <td style="padding: 2px;">Logic symbol</td> <td style="text-align: right; padding: 2px;">$\frac{1}{2}$</td> </tr> <tr> <td style="padding: 2px;">Truth table</td> <td style="text-align: right; padding: 2px;">$\frac{1}{2}$</td> </tr> </table> </div> <p>OR gate</p> <p>Logic symbol of OR gate</p> <div style="text-align: center; margin: 10px 0;">  </div> <p>Truth table of OR gate</p> <table border="1" style="margin: 10px auto; border-collapse: collapse; text-align: center;"> <thead> <tr style="background-color: #0056b3; color: white;"> <th colspan="2">Input</th> <th>Output</th> </tr> <tr style="background-color: #0056b3; color: white;"> <th>A</th> <th>B</th> <th>Y</th> </tr> </thead> <tbody> <tr> <td>0</td> <td>0</td> <td>0</td> </tr> <tr> <td>0</td> <td>1</td> <td>1</td> </tr> <tr> <td>1</td> <td>0</td> <td>1</td> </tr> <tr> <td>1</td> <td>1</td> <td>1</td> </tr> </tbody> </table>	Identification of equivalent gate	1	Logic symbol	$\frac{1}{2}$	Truth table	$\frac{1}{2}$	Input		Output	A	B	Y	0	0	0	0	1	1	1	0	1	1	1	1	1	
Identification of equivalent gate	1																										
Logic symbol	$\frac{1}{2}$																										
Truth table	$\frac{1}{2}$																										
Input		Output																									
A	B	Y																									
0	0	0																									
0	1	1																									
1	0	1																									
1	1	1																									
14.	<div style="border: 1px solid black; padding: 5px; margin-bottom: 10px;"> <table style="width: 100%; border-collapse: collapse;"> <tr> <td style="padding: 2px;">(i) To show $r_1 = r_2 = \frac{A}{2}$</td> <td style="text-align: right; padding: 2px;">1</td> </tr> <tr> <td style="padding: 2px;">(ii) To show $D_m = 2i - A$</td> <td style="text-align: right; padding: 2px;">1</td> </tr> </table> </div> <p>(i) From given figure, $A = r_1 + r_2$ As ray QR is parallel to the base BC, then $r_1 = r_2$, and $i = e$ Therefore, $2r_1$ (or $2r_2$) = A $\Rightarrow r_1 = r_2 = A/2$</p> <p>(ii) $D = (i - r_1) + (e - r_2)$ $D = (i + e) - (r_1 + r_2)$ or $D = 2i - A$</p>	(i) To show $r_1 = r_2 = \frac{A}{2}$	1	(ii) To show $D_m = 2i - A$	1	<p>$\frac{1}{2}$</p> <p>$\frac{1}{2}$</p> <p>$\frac{1}{2}$</p> <p>$\frac{1}{2}$</p>	2																				
(i) To show $r_1 = r_2 = \frac{A}{2}$	1																										
(ii) To show $D_m = 2i - A$	1																										

15.	<div style="border: 1px solid black; padding: 5px; margin-bottom: 10px;"> <table style="width: 100%; border-collapse: collapse;"> <tr> <td style="width: 70%;">Definition</td> <td style="text-align: right;">1</td> </tr> <tr> <td>Block Diagram of modulator</td> <td style="text-align: right;">1</td> </tr> </table> </div> <p>Process of (appropriate) superimposition of low frequency message signal, over a high frequency carrier wave, is called a Modulation.</p> <div style="text-align: center; margin: 10px 0;"> </div> <p>(Note: Award this 1 mark if the student just draws the boxes and writes their functions without writing any mathematical expressions.)</p>	Definition	1	Block Diagram of modulator	1	1	
Definition	1						
Block Diagram of modulator	1						
16.	<div style="border: 1px solid black; padding: 5px; margin-bottom: 10px;"> <table style="width: 100%; border-collapse: collapse;"> <tr> <td style="width: 70%;">a) Explanation</td> <td style="text-align: right;">1</td> </tr> <tr> <td>b) Schematic Diagram</td> <td style="text-align: right;">1</td> </tr> </table> </div> <p>a) An oscillating charge produces an oscillating electric field in space, which produces an oscillating magnetic field. The oscillating electric and magnetic fields regenerate each other, and this results in the production of e-m waves in space.</p> <p>b)</p> <div style="text-align: center; margin: 10px 0;"> </div>	a) Explanation	1	b) Schematic Diagram	1	1	2
a) Explanation	1						
b) Schematic Diagram	1						
17.	<div style="border: 1px solid black; padding: 5px; margin-bottom: 10px;"> <table style="width: 100%; border-collapse: collapse;"> <tr> <td style="width: 70%;">Energy level diagrams for n & p type</td> <td style="text-align: right;">½ + ½</td> </tr> <tr> <td>Marking of donor & acceptor level</td> <td style="text-align: right;">½ + ½</td> </tr> </table> </div> <p>Energy bands of n-type at $T > 0$ Energy bands of p type at $T > 0$</p>	Energy level diagrams for n & p type	½ + ½	Marking of donor & acceptor level	½ + ½		
Energy level diagrams for n & p type	½ + ½						
Marking of donor & acceptor level	½ + ½						

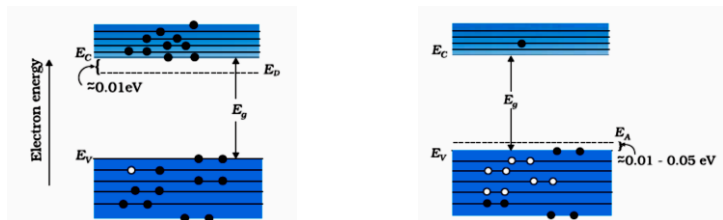

1/2 + 1/2

1/2 + 1/2

[Note: Deduct only 1/2 mark in total, if a student does not write the energy values corresponding to the donor and acceptor energy levels.]

OR

Energy Band diagrams	1
Distinction between metal and insulator	1

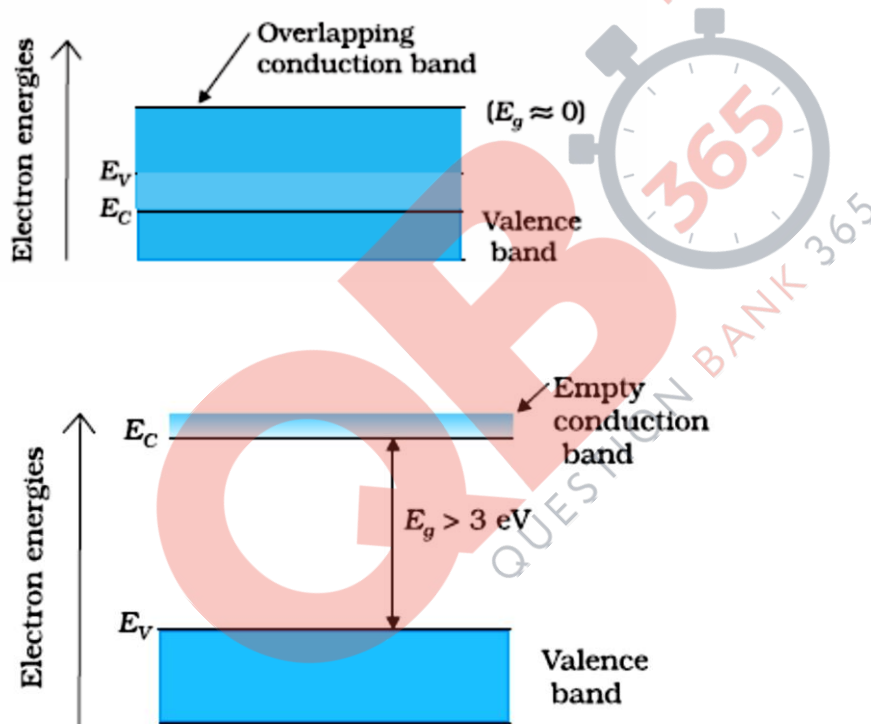

1

Metal	Insulators
1. Conduction band and valence band overlap on each other.	1. There is large energy gap between conduction band and valence band.
2. Conduction band is partially filled and valence band is partially empty.	2. Conduction band is empty as no electrons can be excited to it from valence band

1

(Award 1 1/2 marks for writing two relevant differences even when the diagrams have not been drawn.)

2

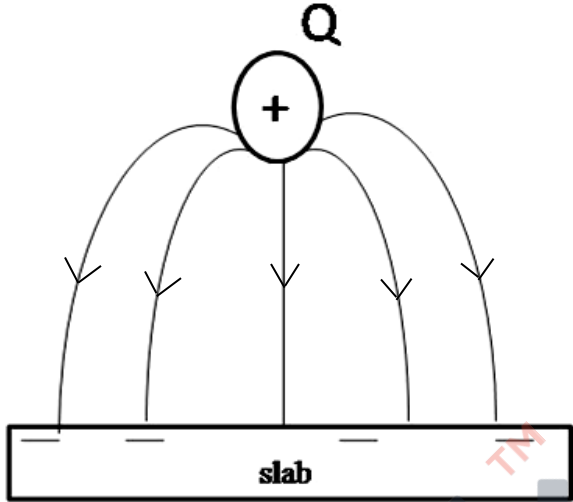
(a)		1							
b) (i)	For region II, $E_{II} = \frac{1}{2\epsilon_0}(\sigma_1 - \sigma_2)$ towards right side / from Sheet A to Sheet B	½							
(ii)	For region III, $E_{III} = \frac{1}{2\epsilon_0}(\sigma_1 + \sigma_2)$ towards right side /away from two sheets.	½							
21.	<table border="1" style="width: 100%; border-collapse: collapse;"> <tbody> <tr> <td style="padding: 5px;">a) Magnitude and direction of magnetic field at 'b'</td> <td style="text-align: right; padding: 5px;">½ + ½</td> </tr> <tr> <td style="padding: 5px;">Magnitude and nature of force</td> <td style="text-align: right; padding: 5px;">½ + ½</td> </tr> <tr> <td style="padding: 5px;">b) Diagram showing magnetic field and force</td> <td style="text-align: right; padding: 5px;">1</td> </tr> </tbody> </table>	a) Magnitude and direction of magnetic field at 'b'	½ + ½	Magnitude and nature of force	½ + ½	b) Diagram showing magnetic field and force	1		3
a) Magnitude and direction of magnetic field at 'b'	½ + ½								
Magnitude and nature of force	½ + ½								
b) Diagram showing magnetic field and force	1								
a)	The magnitude of magnetic field produced by conductor 'a', at a point on the conductor b: $B = \frac{\mu_0 I_a}{2\pi d}$	½							
	Direction of magnetic field will be inward / outward perpendicular to the plane of two conductors, depending on the direction of flow of current in conductor 'a'.	½							

	<p>Force per unit length = $\frac{\mu_0 I_a I_b}{2\pi d}$, Nature: attractive</p> <p>(b)</p> <p>(Any one of the diagrams)</p>	<p>1/2 1/2 1</p>	<p>3</p>
<p>22.</p>	<div style="border: 1px solid black; padding: 5px; margin-bottom: 10px;"> <p>Diagram of sky wave and space wave modes of propagation 1/2 + 1/2 Description of sky and space wave propagation 1/2 + 1/2 Frequency range of sky and space wave 1/2 + 1/2</p> </div> <p>(i) Sky wave and space wave propagation</p>		

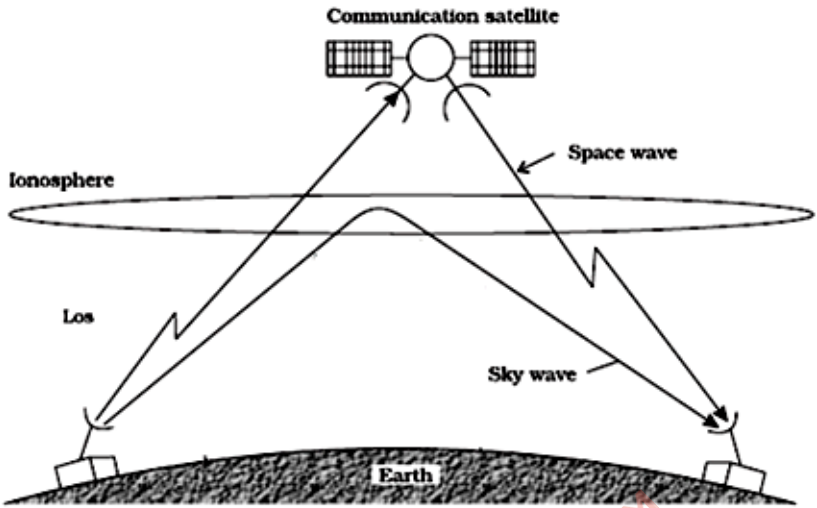
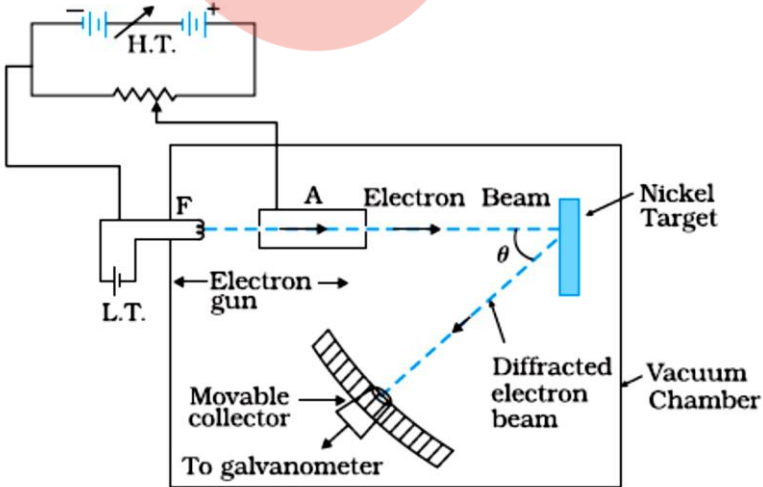
	 <p>Communication satellite</p> <p>Ionosphere</p> <p>Space wave</p> <p>Sky wave</p> <p>Earth</p> <p>Los</p> <ul style="list-style-type: none"> - Sky wave propagation is due to ionospheric reflection of radio waves back to the earth. - Space wave propagation is by line of sight propagation, directly between transmitter to receiver / or by satellite. - Frequency Range of sky wave – few MHz to 40 MHz - Frequency Range of space wave – above 40 MHz 	<p>$\frac{1}{2} + \frac{1}{2}$</p> <p>$\frac{1}{2}$</p> <p>$\frac{1}{2}$</p> <p>$\frac{1}{2}$</p> <p>$\frac{1}{2}$</p>	<p>3</p>
<p>23.</p>	<div style="border: 1px solid black; padding: 5px; margin-bottom: 10px;"> <p>a) Description with the help of diagram $1\frac{1}{2}$</p> <p>b) Derivation of expression $1\frac{1}{2}$</p> </div> <p>(a) Diagram</p>  <p>H.T.</p> <p>L.T.</p> <p>F</p> <p>A</p> <p>Electron Beam</p> <p>Nickel Target</p> <p>Electron gun</p> <p>Diffracted electron beam</p> <p>Vacuum Chamber</p> <p>Movable collector</p> <p>To galvanometer</p> <p>θ</p> <p>This experiment confirms the wave nature of electron.</p>	<p>1</p> <p>$\frac{1}{2}$</p>	

QB365 - Question Bank Software

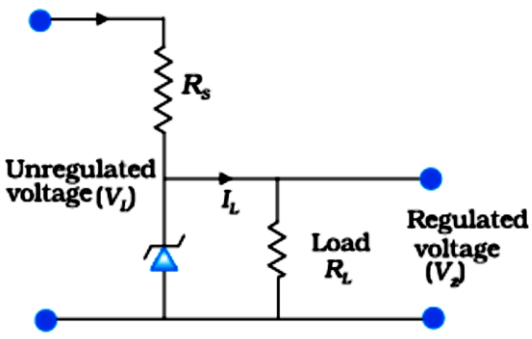
	<p>(b) $\lambda = \frac{h}{p} = \frac{h}{\sqrt{2mK}}$</p> <p>$\therefore$ But $K = \text{K.E.} = eV$</p> <p>$\therefore \lambda = \frac{h}{\sqrt{2meV}}$</p>	1/2	
		1/2	
		1/2	3
24.	<p>a) Two values displayed by Puja and her father 1+1</p> <p>b) Stating the phenomenon 1</p>		
	<p>(a) Any one of the values displayed by Puja – curiosity / observation etc. Any one of the values displayed by father – concern / knowledge / sense of duty etc.</p> <p>(b) Interference of sunlight due to the soap bubble.</p>	1 1 1	3
25.	<p>a) Reason of heavily doping of p and n sides 1</p> <p>b) Circuit diagram 1</p> <p style="padding-left: 20px;">Working 1</p>		
	<p>(a) Due to heavy doping, the depletion layer become very thin and electric field, across the junction, becomes very high even for a small reverse bias voltage.</p> <p>(b) Circuit diagram</p>	1	
		1	
	Any increase/ decrease in the input voltage results in increase/ decrease of the	1	

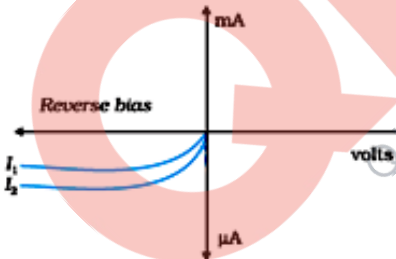
	<p>voltage drop across R_s, without any change in the voltage across the Zener diode.</p> <p style="text-align: center;">OR</p> <div style="border: 1px solid black; padding: 10px; margin: 10px auto; width: fit-content;"> <p>a) Fabrication of photodiode 1</p> <p>b) (i) Working of photo diode 1</p> <p style="padding-left: 20px;">(ii) V – I characteristics 1</p> </div> <p>(a) Photo diode is fabricated with a transparent window to allow light to fall on the diode. 1</p> <p>(b) (i) Working:- When reversed biased photo diode is illuminated with light of energy greater than the forbidden energy gap (E_g), electron hole pairs are generated in, or near, the depletion region. Due to junction field, electrons are collected on the n-side and holes on p-side, giving rise to a potential difference. 1</p> <p>(b)(ii)</p> <div style="text-align: center;">  <p style="margin-top: 10px;">$I_2 > I_1$</p> </div> <p style="text-align: right; margin-top: 20px;">3</p>		
26.	<div style="border: 1px solid black; padding: 10px; margin: 10px auto; width: fit-content;"> <p>i) Distinction 1</p> <p>ii) Polaroid & its working $\frac{1}{2} + \frac{1}{2}$</p> <p>iii) Polarization of sunlight – explanation 1</p> </div>		

QB365 - Question Bank Software

	<p>i) In a beam of Unpolarized light, the vibrations of light vectors are in all directions in a plane perpendicular to direction of propagation. In polarized light, these vibrations are only along one direction.</p> <p>ii) Polaroids consist of long chain of molecules aligned in a particular direction. It polarizes light as it allows only one component of light (electric vectors parallel to the pass axis) to pass through it while the other component is absorbed.</p> <p>iii) The observer receives scattered light corresponding to only one of the two sets of accelerated charges i.e. electrons oscillating perpendicular to the direction of propagation.</p>	<p align="center">1</p> <p align="center">$\frac{1}{2} + \frac{1}{2}$</p> <p align="center">1</p>	<p align="center">3</p>
<p>27.</p>	<div style="border: 1px solid black; padding: 5px; margin-bottom: 10px;"> <p>i. Calculation of capacitance 1</p> <p>ii. Calculation of charge 1</p> <p>iii. Effect on the charge on the plate 1</p> </div> <p>i. $C = \frac{\epsilon_0 A}{d}$</p> $= \frac{8.85 \times 10^{-12} \times 6 \times 10^{-3}}{3 \times 10^{-3}} \text{ F}$ $= 17.7 \times 10^{-12} \text{ F} = (17.7 \text{ pf})$ <p>ii. $Q = CV$</p> $= 17.7 \times 10^{-12} \times 100 \text{ C}$ $= 17.7 \times 10^{-10} \text{ C} = (1.77 \text{ nC})$ <p>iii. $Q' = KQ$</p> $= 6 \times 17.7 \times 10^{-10} \text{ C}$ $= 106.2 \times 10^{-10} \text{ C} = (10.62 \times 10^{-9} \text{ C})$ $= 10.62 \text{ nC}$	<p align="center">$\frac{1}{2}$</p> <p align="center">$\frac{1}{2}$</p> <p align="center">$\frac{1}{2}$</p> <p align="center">$\frac{1}{2}$</p> <p align="center">$\frac{1}{2}$</p> <p align="center">$\frac{1}{2}$</p>	<p align="center">3</p>

28.	<div style="border: 1px solid black; padding: 5px; margin-bottom: 10px;"> <p>a) Expression for total energy of electron 3</p> <p>b) Calculation of wavelengths 1+1</p> </div> <p>a) $mvr = \frac{nh}{2\pi}$</p> <p>$\frac{mv^2}{r} = \frac{1}{4\pi\epsilon_0} \frac{e^2}{r^2}$</p> <p>$r = \frac{e^2}{4\pi\epsilon_0 mv^2}$</p> <p>$r = \frac{ze^2}{4\pi\epsilon_0 m \left(\frac{nh}{2\pi mr}\right)^2}$</p> <p>$\Rightarrow r = \frac{\epsilon_0 n^2 h^2}{\pi m e^2}$</p> <p>Potential energy $U = -\frac{1}{4\pi\epsilon_0} \cdot \frac{e^2}{r}$</p> <p style="margin-left: 100px;">$= -\frac{me^4}{4\epsilon_0 n^2 h^2}$</p> <p>$KE = \frac{1}{2} mv^2 = \frac{1}{2} m \left(\frac{nh}{2\pi mr}\right)^2$</p> <p style="margin-left: 100px;">$= \frac{n^2 h^2 \pi^2 m^2 e^4}{8\pi^2 m \epsilon_0^2 n^4 h^4}$</p> <p>$KE = \frac{me^4}{8\epsilon_0^2 n^2 h^2}$</p> <p>$TE = KE + PE$</p> <p style="margin-left: 100px;">$= -\frac{me^4}{8\epsilon_0^2 n^2 h^2}$</p> <p>(Note: If a candidate does not use Bohr's postulates and writes the final expression for the energy in terms of r award 1 mark.)</p> <p>b) Rydberg formula :For first member of Lyman series</p> <p style="margin-left: 40px;">$\frac{1}{\lambda} = R \left(\frac{1}{1^2} - \frac{1}{2^2}\right)$</p> <p style="margin-left: 40px;">$\lambda = \frac{4}{3R}$</p> <p>For first member of Balmer Series</p> <p style="margin-left: 40px;">$\frac{1}{\lambda} = R \left(\frac{1}{2^2} - \frac{1}{3^2}\right)$</p>	<p>$\frac{1}{2}$</p> <p>$\frac{1}{2}$</p> <p>$\frac{1}{2}$</p> <p>$\frac{1}{2}$</p> <p>$\frac{1}{2}$</p> <p>$\frac{1}{2}$</p> <p>$\frac{1}{2}$</p> <p>$\frac{1}{2}$</p> <p>$\frac{1}{2}$</p> <p>$\frac{1}{2}$</p> <p>$\frac{1}{2}$</p> <p>$\frac{1}{2}$</p>	
-----	---	---	--

$\lambda = \frac{36}{5R}$ <p>(Note: Award full marks if the student calculates the value of λ in the two cases by taking the value of $R = 1.097 \times 10^7 \text{ m}^{-1}$)</p> <p style="text-align: center;">OR</p> <table border="1" style="width: 100%; margin: 10px auto;"> <tbody> <tr> <td style="width: 70%;">a) Definition of (i) half life</td> <td style="width: 30%; text-align: right;">1</td> </tr> <tr> <td style="padding-left: 40px;">(ii) average life</td> <td style="text-align: right;">1</td> </tr> <tr> <td style="padding-left: 40px;">Relationship of half life & average life with decay constant</td> <td style="text-align: right;">$\frac{1}{2} + \frac{1}{2}$</td> </tr> <tr> <td>b) Calculation of time taken</td> <td style="text-align: right;">2</td> </tr> </tbody> </table> <p>(a) Definition:</p> <p>(i) Half life: Time taken by a radioactive nuclei to reduce to half of the initial number of radio nuclei. 1</p> <p>(ii) Average life – Ratio of total life time of all radioactive nuclei, to the total number of nuclei in the sample. 1</p> <p>Relation between half life and decay constant:</p> $T_{1/2} = \frac{0.693}{\lambda} \quad \text{1/2}$ <p>Relation between average life and decay constant $\tau = \frac{1}{\lambda}$ 1/2</p> <p>(b)</p> $N = N_0 e^{-\lambda t}$ $\frac{3}{4} N_0 = N_0 e^{-(0.3465)t}$ $e^{(0.3465)t} = \frac{4}{3}$ $0.3465 \times t = \log_e\left(\frac{4}{3}\right)$ $= 2.303[\log 4 - \log 3]$ $= 2.303[0.6020 - 0.4771]$ $= 2.303 \times 0.1249$ $t = \frac{2.303 \times 0.1249}{0.3465}$ <p>$\therefore t = 0.83 \text{ days or } 19.92 \text{ hours}$ 1/2</p>	a) Definition of (i) half life	1	(ii) average life	1	Relationship of half life & average life with decay constant	$\frac{1}{2} + \frac{1}{2}$	b) Calculation of time taken	2	<p>1/2</p>
a) Definition of (i) half life	1								
(ii) average life	1								
Relationship of half life & average life with decay constant	$\frac{1}{2} + \frac{1}{2}$								
b) Calculation of time taken	2								

	<p><u>Alternatively:</u> Also accept if the student takes $N=25\%$ $N_0 = \frac{1}{4} N_0$ and does the calculations as follows.</p> $T_{\frac{1}{2}} = \frac{0.693}{\lambda} = \frac{0.693}{0.3465} = 2 \text{ days}$ <p style="text-align: center;"> $N = \frac{N_0}{2^n}$ Time taken to reduce to 50% = 2days (one half) </p> <p>or $\frac{25}{100} = \frac{1}{2^n}$</p> <p>$\Rightarrow n = 2$</p> <p>But $\frac{t}{T_{\frac{1}{2}}} = n,$ $\Rightarrow t = 4 \text{ days}$</p> <p style="text-align: center;"> Additional time taken to reduce to (one fourth) 25% = 2days \therefore Total time taken to reduce to one fourth (25%) = 2+2days = 4days </p>	<p>$\frac{1}{2}$</p> <p>$\frac{1}{2}$</p> <p>$\frac{1}{2}$</p> <p>$\frac{1}{2}$</p>	<p>5</p>												
29.	<table style="width: 100%; border-collapse: collapse;"> <tr> <td style="width: 60%;">(a) Principle of potentiometer</td> <td style="text-align: right;">$\frac{1}{2}$</td> </tr> <tr> <td> Definition of potential gradient</td> <td style="text-align: right;">$\frac{1}{2}$</td> </tr> <tr> <td> Expression for potential gradient</td> <td style="text-align: right;">1</td> </tr> <tr> <td>(b) Determination of</td> <td></td> </tr> <tr> <td> i. $\frac{e_1}{e_2}$</td> <td style="text-align: right;">$1\frac{1}{2}$</td> </tr> <tr> <td> ii. Position of null point for cell E_1 only</td> <td style="text-align: right;">$1\frac{1}{2}$</td> </tr> </table>	(a) Principle of potentiometer	$\frac{1}{2}$	Definition of potential gradient	$\frac{1}{2}$	Expression for potential gradient	1	(b) Determination of		i. $\frac{e_1}{e_2}$	$1\frac{1}{2}$	ii. Position of null point for cell E_1 only	$1\frac{1}{2}$	<p>$\frac{1}{2}$</p> <p>$\frac{1}{2}$</p> <p>$\frac{1}{2}$</p>	
(a) Principle of potentiometer	$\frac{1}{2}$														
Definition of potential gradient	$\frac{1}{2}$														
Expression for potential gradient	1														
(b) Determination of															
i. $\frac{e_1}{e_2}$	$1\frac{1}{2}$														
ii. Position of null point for cell E_1 only	$1\frac{1}{2}$														

	$K = \frac{I\rho \frac{l}{A}}{l}$ $K = \frac{I\rho}{A}$	1/2	
	<p>(b) (i) $\frac{e_1 - e_2}{e_1 + e_2} = \frac{120}{300} = \frac{2}{5}$</p> $\frac{e_1}{e_2} = \frac{7}{3}$	1	
	<p>(ii) $\frac{e_1 + e_2}{e_1} = \frac{300}{x}$</p>	1/2	
	<p>$\Rightarrow x = 210\text{cm}$ (where x is the position of null point with cell e_1 only.)</p>	1	
	OR		
	<p>(a) Definition of drift velocity 1 mark Expression for current density 1 mark</p> <p>(b) Calculation of power 3 marks</p>		
	<p>(a) Drift velocity – The average velocity gained by free electrons, when a unit electric field is applied across the conductor.</p>	1	
	$I = neAv_d$ $= neA \frac{eE}{m} \tau$	1/2	
	<p>\therefore current density $J = \frac{I}{A} = \frac{ne^2 E \tau}{m}$</p>	1/2	
	<p>(b) $P = I^2 R$ Current flowing through the resistance 2Ω</p> $I = \sqrt{\frac{200}{2}} = 10\text{A}$	1/2	
	<p>\therefore Potential drop across the 2Ω resistor = 20V Therefore Potential across parallel combination of 40Ω and $10\Omega = 80\text{V}$</p>	1/2	
	<p>Current through 5Ω; $I = \frac{80}{10} \text{A} = 8\text{A}$</p>	1	
	<p>\therefore Power dissipated in the 5Ω resistor = $(8)^2 \times 5\text{W} = 320\text{W}$</p>	1/2	
			5

30.

- | | |
|---|-----|
| (a) Labelled ray diagram | 2 |
| Considerations required in selection of lenses | |
| (i) for large magnifying power | 1/2 |
| (ii) high Resolution | 1/2 |
| (b) Calculation of the distance between objective and eye piece | 2 |

(a)

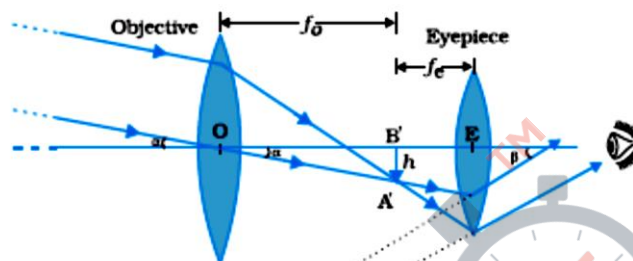

2

Alternatively

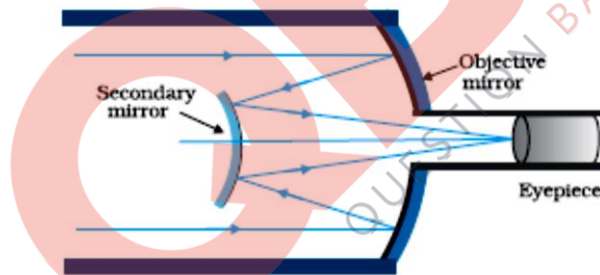

(Note : deduct 1 mark for not labelling of the diagram)

For large magnifying power f_o should be large and f_e should be small.

1/2

For higher resolution diameter of the objective should be large.

1/2

(b)
$$\frac{1}{v_o} - \frac{1}{u_o} = \frac{1}{f_o}$$

$$\frac{1}{v_o} = \frac{1}{f_o} + \frac{1}{u_o} = \frac{1}{1.25} - \frac{1}{2.5} = \frac{1}{2.5}$$

$$v_o = 2.5 \text{ cm}$$

$$L = |f_o| + |f_e| \quad (\because v_o = f_o)$$

$$= (2.5 + 5.0) \text{ cm} = 7.5 \text{ cm}$$

1/2

1/2

1/2

1/2

OR			
(a) Three distinctive features between the patterns of interference and diffraction fringes. 3			
(b) Calculation of width of slit. 2			
Interference	Diffraction		
1. Width of central maxima is same as that of the other fringes.	1. Width of central maxima is more than of the other fringes.	1	
2. All bright fringes are of equal intensity.	2. Intensity of secondary maxima keeps on decreasing.	1	
3. Large number of fringes.	3. Only a small number of fringes.	1	
(or any other relevant difference)			
(b) $y_n = \frac{n\lambda D}{d}$ $d = \frac{n\lambda D}{y_n}$ $= \frac{1 \times 500 \times 10^{-9} \times 1}{2.5 \times 10^{-3}} \text{ m}$ $= 2 \times 10^{-4} \text{ m} \quad (=0.2\text{mm})$		½	
		½	
		1	
			5