

Series ONS

SET-3

कोड नं.
Code No. **55/3/C**

रोल नं.
Roll No.

परीक्षार्थी कोड को उत्तर-पुस्तिका के मुख-पृष्ठ पर अवश्य लिखें।

Candidates must write the Code on the title page of the answer-book.

- कृपया जाँच कर लें कि इस प्रश्न-पत्र में मुद्रित पृष्ठ **16** हैं।
- प्रश्न-पत्र में दाहिने हाथ की ओर दिए गए कोड नम्बर को छात्र उत्तर-पुस्तिका के मुख-पृष्ठ पर लिखें।
- कृपया जाँच कर लें कि इस प्रश्न-पत्र में **26** प्रश्न हैं।
- कृपया प्रश्न का उत्तर लिखना शुरू करने से पहले, प्रश्न का क्रमांक अवश्य लिखें।
- इस प्रश्न-पत्र को पढ़ने के लिए 15 मिनट का समय दिया गया है। प्रश्न-पत्र का वितरण पूर्वाह्न में 10.15 बजे किया जाएगा। 10.15 बजे से 10.30 बजे तक छात्र केवल प्रश्न-पत्र को पढ़ेंगे और इस अवधि के दौरान वे उत्तर-पुस्तिका पर कोई उत्तर नहीं लिखेंगे।
- Please check that this question paper contains **16** printed pages.
- Code number given on the right hand side of the question paper should be written on the title page of the answer-book by the candidate.
- Please check that this question paper contains **26** questions.
- **Please write down the Serial Number of the question before attempting it.**
- 15 minute time has been allotted to read this question paper. The question paper will be distributed at 10.15 a.m. From 10.15 a.m. to 10.30 a.m., the students will read the question paper only and will not write any answer on the answer-book during this period.

भौतिक विज्ञान (सैद्धान्तिक)

PHYSICS (Theory)

निर्धारित समय : 3 घण्टे

अधिकतम अंक : 70

Time allowed : 3 hours

Maximum Marks : 70

55/3/C

1

P.T.O.

सामान्य निर्देश :

- (i) सभी प्रश्न अनिवार्य हैं। इस प्रश्न-पत्र में कुल 26 प्रश्न हैं।
- (ii) इस प्रश्न-पत्र के 5 भाग हैं : खण्ड अ, खण्ड ब, खण्ड स, खण्ड द और खण्ड य।
- (iii) खण्ड अ में 5 प्रश्न हैं, प्रत्येक का 1 अंक है। खण्ड ब में 5 प्रश्न हैं, प्रत्येक के 2 अंक हैं। खण्ड स में 12 प्रश्न हैं, प्रत्येक के 3 अंक हैं। खण्ड द में 4 अंक का एक मूल्याधारित प्रश्न है और खण्ड य में 3 प्रश्न हैं, प्रत्येक के 5 अंक हैं।
- (iv) प्रश्न-पत्र में समग्र पर कोई विकल्प नहीं है। तथापि, दो अंकों वाले एक प्रश्न में, तीन अंकों वाले एक प्रश्न में और पाँच अंकों वाले तीनों प्रश्नों में आन्तरिक चयन प्रदान किया गया है। ऐसे प्रश्नों में आपको दिए गए चयन में से केवल एक प्रश्न ही करना है।
- (v) जहाँ आवश्यक हो आप निम्नलिखित भौतिक नियतांकों के मानों का उपयोग कर सकते हैं :

$$c = 3 \times 10^8 \text{ m/s}$$

$$h = 6.63 \times 10^{-34} \text{ Js}$$

$$e = 1.6 \times 10^{-19} \text{ C}$$

$$\mu_0 = 4\pi \times 10^{-7} \text{ T m A}^{-1}$$

$$\epsilon_0 = 8.854 \times 10^{-12} \text{ C}^2 \text{ N}^{-1} \text{ m}^{-2}$$

$$\frac{1}{4\pi\epsilon_0} = 9 \times 10^9 \text{ N m}^2 \text{ C}^{-2}$$

$$\text{इलेक्ट्रॉन का द्रव्यमान} = 9.1 \times 10^{-31} \text{ kg}$$

$$\text{न्यूट्रॉन का द्रव्यमान} = 1.675 \times 10^{-27} \text{ kg}$$

$$\text{प्रोटॉन का द्रव्यमान} = 1.673 \times 10^{-27} \text{ kg}$$

$$\text{आवोगाद्रो संख्या} = 6.023 \times 10^{23} \text{ प्रति ग्राम मोल}$$

$$\text{बोल्ट्ज़मान नियतांक} = 1.38 \times 10^{-23} \text{ JK}^{-1}$$

General Instructions :

- (i) *All questions are **compulsory**. There are **26** questions in all.*
- (ii) *This question paper has **five** sections : Section A, Section B, Section C, Section D and Section E.*
- (iii) *Section A contains **five** questions of **one** mark each, Section B contains **five** questions of **two** marks each, Section C contains **twelve** questions of **three** marks each, Section D contains **one** value based question of **four** marks and Section E contains **three** questions of **five** marks each.*
- (iv) *There is no overall choice. However, an internal choice has been provided in **one** question of **two** marks, **one** question of **three** marks and all the **three** questions of **five** marks weightage. You have to attempt only **one** of the choices in such questions.*
- (v) *You may use the following values of physical constants wherever necessary :*

$$c = 3 \times 10^8 \text{ m/s}$$

$$h = 6.63 \times 10^{-34} \text{ Js}$$

$$e = 1.6 \times 10^{-19} \text{ C}$$

$$\mu_0 = 4\pi \times 10^{-7} \text{ T m A}^{-1}$$

$$\epsilon_0 = 8.854 \times 10^{-12} \text{ C}^2 \text{ N}^{-1} \text{ m}^{-2}$$

$$\frac{1}{4\pi\epsilon_0} = 9 \times 10^9 \text{ N m}^2 \text{ C}^{-2}$$

$$\text{Mass of electron} = 9.1 \times 10^{-31} \text{ kg}$$

$$\text{Mass of neutron} = 1.675 \times 10^{-27} \text{ kg}$$

$$\text{Mass of proton} = 1.673 \times 10^{-27} \text{ kg}$$

$$\text{Avogadro's number} = 6.023 \times 10^{23} \text{ per gram mole}$$

$$\text{Boltzmann constant} = 1.38 \times 10^{-23} \text{ JK}^{-1}$$

खण्ड - अ
SECTION - A

1. सूर्योदय और सूर्यास्त के समय सूर्य लाल क्यों प्रतीत होता है? 1
Why does sun appear red at sunrise and sunset ?
2. संचार व्यवस्था के आवश्यक अवयवों के नाम लिखिए। 1
Name the essential components of a communication system.
3. किसी बाह्य चुम्बकीय क्षेत्र में रखने पर प्रतिचुम्बकीय पदार्थों का व्यवहार अनुचुम्बकीय पदार्थों से किस प्रकार भिन्न होता है? 1
In what way is the behaviour of a diamagnetic material different from that of a paramagnetic, when kept in an external magnetic field ?
4. तीन सर्वसम सेलों के श्रेणी संयोजन के सिरों पर वोल्टता और धारा के बीच विचरण का ग्राफ नीचे दिया गया है। प्रत्येक सेल का emf और आन्तरिक प्रतिरोध कितना है? 1

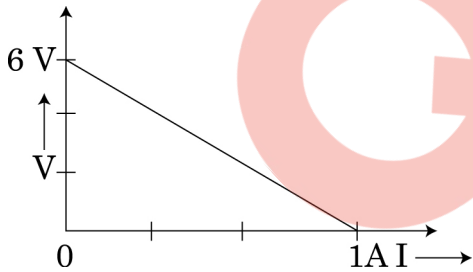

The plot of the variation of potential difference across a combination of three identical cells in series, versus current is shown below. What is the emf and internal resistance of each cell ?

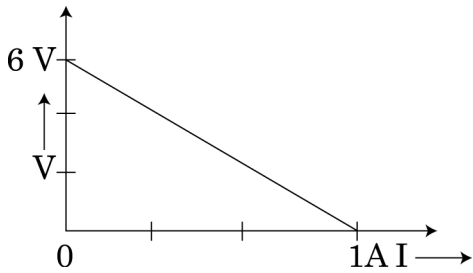

5. किसी आवेश 'q' को द्विध्रुव आघूर्ण 'p' के किसी द्विध्रुव के ऊपर स्थित किसी बिन्दु A से द्विध्रुव के नीचे स्थित किसी बिन्दु B तक विषुवतीय तल में बिना किसी त्वरण के ले जाया जाता है। इस प्रक्रिया में किया गया कार्य ज्ञात कीजिए। 1

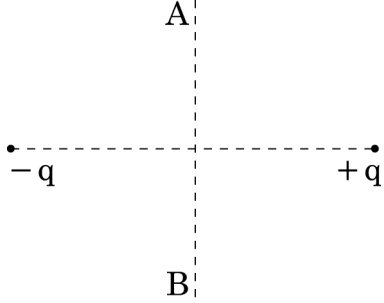

A charge 'q' is moved from a point A above a dipole of dipole moment 'p' to a point B below the dipole in equatorial plane without acceleration. Find the work done in the process.

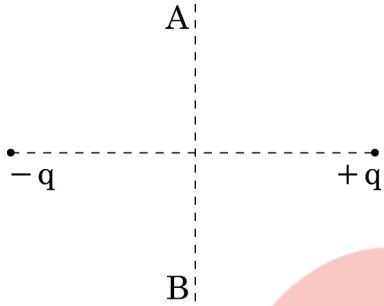

खण्ड - ब
SECTION - B

6. अपवर्तनांक 1.5 के पदार्थ के बने किसी प्रिज्म BAC के फलक BA पर कोई किरण PQ अभिलम्बवत् आपतन करती हुई अपवर्तित होती है। प्रिज्म में इस किरण का पथ आरेखित कीजिए। प्रिज्म के किस फलक से यह किरण निर्गत होगी? अपने उत्तर की पुष्टि कीजिए। 2

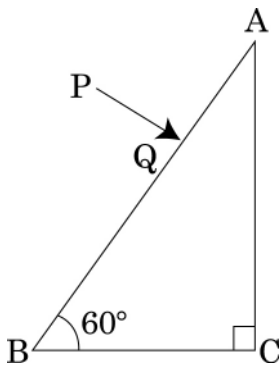

A ray PQ incident normally on the refracting face BA is refracted in the prism BAC made of material of refractive index 1.5. Complete the path of ray through the prism. From which face will the ray emerge? Justify your answer.

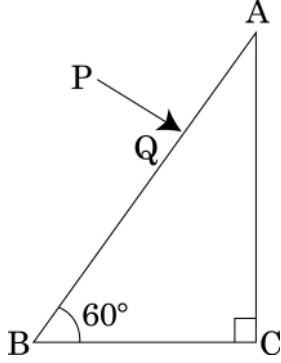

7. हाइड्रोजन परमाणु की $n=2$ अवस्था में चक्कर लगाने वाले इलेक्ट्रॉन की दे ब्राग्ली तरंगदैर्घ्य परिकलित कीजिए।
Calculate the de-Broglie wavelength of the electron orbiting in the $n=2$ state of hydrogen atom. 2
8. माडुलन सूचकांक की परिभाषा लिखिए। इसे निम्न क्यों रखा जाता है? बैंडपास फ़िल्टर की भूमिका क्या है?
Define modulation index. Why is it kept low? What is the role of a bandpass filter? 2
9. आरेख में दर्शाए अनुसार $12V$ emf और $2\ \Omega$ आन्तरिक प्रतिरोध की कोई बैटरी $4\ \Omega$ प्रतिरोधक से संयोजित है।
(a) यह दर्शाइए कि किसी वोल्टमीटर को बारी-बारी से बैटरी के सिरों से संयोजित करने तथा प्रतिरोधक के सिरों से संयोजित करने पर समान पाठ्यांक प्राप्त होते हैं।
(b) परिपथ में वोल्टता और धारा मापने के लिए वोल्टमीटर को पार्श्व तथा ऐमीटर को श्रेणी क्रम में क्यों संयोजित किया जाता है? 2

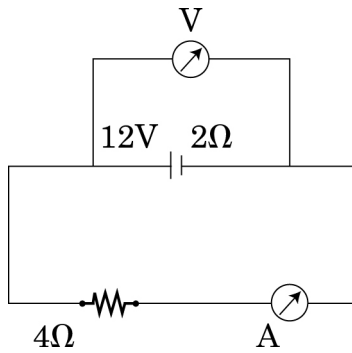

A battery of emf 12V and internal resistance $2\ \Omega$ is connected to a $4\ \Omega$ resistor as shown in the figure.

- (a) Show that a voltmeter when placed across the cell and across the resistor, in turn, gives the same reading.
- (b) To record the voltage and the current in the circuit, why is voltmeter placed in parallel and ammeter in series in the circuit ?

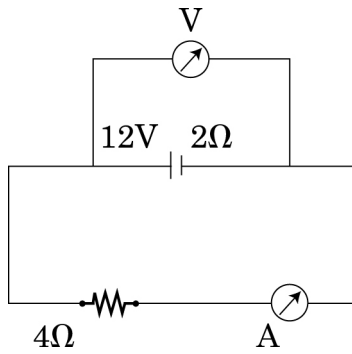

10. आयनन ऊर्जा की परिभाषा लिखिए।

2

यदि हाइड्रोजन परमाणु के इलेक्ट्रॉन को इससे 200 गुने द्रव्यमान के किसी कण, जिस पर आवेश की मात्रा समान है, से प्रतिस्थापित कर दिया जाए, तो आयनन ऊर्जा में क्या परिवर्तन होगा ?

अथवा

बामर श्रेणी में उत्सर्जित स्पेक्ट्रमी रेखाओं की लघुतम तरंगदैर्घ्य परिकलित कीजिए।

[दिया है, रिडबर्ग नियतांक, $R = 10^7\ \text{m}^{-1}$]

Define ionization energy.

How would the ionization energy change when electron in hydrogen atom is replaced by a particle of mass 200 times that of the electron but having the same charge ?

OR

Calculate the shortest wavelength of the spectral lines emitted in Balmer series.

[Given Rydberg constant, $R = 10^7\ \text{m}^{-1}$]

खण्ड - स

SECTION - C

11. किसी CE-ट्रान्जिस्टर प्रवर्धक के लिए $2\text{ k}\Omega$ संग्राहक प्रतिरोध के सिरों पर शून्य सिग्नल 3
वोल्टता 2 V है। मान लीजिए ट्रान्जिस्टर का धारा प्रवर्धन गुणांक 100 है, यदि आधार प्रतिरोध
 $1\text{ k}\Omega$ है, तो निवेशी सिग्नल वोल्टता और आधार धारा ज्ञात कीजिए।

For a CE-transistor amplifier, the audio signal voltage across the collector resistance of $2\text{ k}\Omega$ is 2 V . Suppose the current amplification factor of the transistor is 100, find the input signal voltage and base current, if the base resistance is $1\text{ k}\Omega$.

12. (i) मेलस का नियम लिखिए। 3

(ii) ध्रुवक और विश्लेषक के बीच कोण (θ) के साथ विश्लेषक से पारगमित प्रकाश की तीव्रता (I) का विचरण दर्शाने के लिए ग्राफ खींचिए।

(iii) ध्रुवण-कोण 60° के किसी माध्यम का अपवर्तनांक कितना होता है ?

(i) State law of Malus.

(ii) Draw a graph showing the variation of intensity (I) of polarised light transmitted by an analyser with angle (θ) between polariser and analyser.

(iii) What is the value of refractive index of a medium of polarising angle 60° ?

13. (i) कुछ MHz से 30 MHz आवृत्ति परिसर की लघु तरंग प्रसारण सेवाएं संचार की किस 3
विधा का उपयोग करती हैं? आरेख द्वारा व्याख्या कीजिए कि इस विधा द्वारा लम्बी दूरियों के संचार को किस प्रकार संपादित किया जाता है ?

(ii) इस विधा में उपयोग होने वाली तरंगों की आवृत्ति की उपरि सीमा क्यों होती है ?

(i) Which mode of propagation is used by shortwave broadcast services having frequency range from a few MHz upto 30 MHz ? Explain diagrammatically how long distance communication can be achieved by this mode.

(ii) Why is there an upper limit to frequency of waves used in this mode ?

14. देहली आवृत्तियों $\nu_A > \nu_B$ के दो प्रकाश सुग्राही पदार्थों A और B के आपतित विकिरणों की तीव्रता के साथ निरोधी विभव के विचरण को दर्शाने के लिए ग्राफ खींचिए। 3
- (i) किस प्रकरण में निरोधी विभव अधिक है और क्यों ?
- (ii) क्या ग्राफ की प्रवणता उपयोग किए गए पदार्थ की प्रकृति पर निर्भर करती है? व्याख्या कीजिए।

Sketch the graphs showing variation of stopping potential with frequency of incident radiations for two photosensitive materials A and B having threshold frequencies $\nu_A > \nu_B$.

- (i) In which case is the stopping potential more and why ?
- (ii) Does the slope of the graph depend on the nature of the material used ? Explain.
15. (i) जब किसी आदर्श प्रेरक को किसी AC स्रोत से संयोजित किया जाता है, तो यह दर्शाइए कि स्रोत द्वारा पूरे चक्र में प्रदान की गयी औसत शक्ति शून्य होती है। 3
- (ii) कोई लैम्प किसी परिवर्ती प्रेरक तथा AC स्रोत के साथ श्रेणी में संयोजित है। यदि कुन्जी को बन्द करके प्रेरक की गुहिका में कोई लोहे की छड़ धंसा दी जाए, तो लैम्प की चमक का क्या होगा? व्याख्या कीजिए।

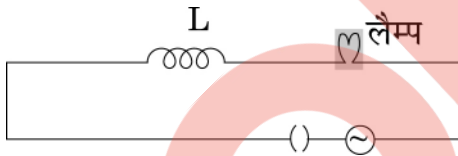

- (i) When an AC source is connected to an ideal inductor show that the average power supplied by the source over a complete cycle is zero.
- (ii) A lamp is connected in series with an inductor and an AC source. What happens to the brightness of the lamp when the key is plugged in and an iron rod is inserted inside the inductor ? Explain.

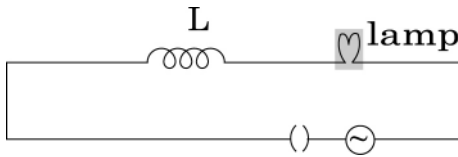

16. (i) आरेख की सहायता से किसी pn संधि में ह्रासी क्षेत्र और रोधिका विभव विकसित होने की व्याख्या कीजिए। 3
- (ii) अर्ध तरंग दिष्टकारी का परिपथ खींचकर इसकी क्रिया विधि की व्याख्या कीजिए।
- (i) Explain with the help of a diagram the formation of depletion region and barrier potential in a pn junction.
- (ii) Draw the circuit diagram of a half wave rectifier and explain its working.

17. (i) वैद्युत चुम्बकीय स्पेक्ट्रम के उस भाग को पहचानिए : 3
- (a) जो वायुयान चालन में रेडार प्रणाली के लिए उपयुक्त होता है।
(b) उच्च चाल के इलेक्ट्रॉनों द्वारा किसी धातु के लक्ष्य पर बमबारी द्वारा उत्पन्न होता है।
- (ii) किसी संधारित्र को आवेशित अथवा अनावेशित करते समय गैल्वेनोमीटर क्षणिक विक्षेप क्यों दर्शाता है? इस प्रेक्षण की व्याख्या के लिए आवश्यक व्यंजक लिखिए।
- (i) Identify the part of the electromagnetic spectrum which is :
(a) suitable for radar system used in aircraft navigation,
(b) produced by bombarding a metal target by high speed electrons.
- (ii) Why does a galvanometer show a momentary deflection at the time of charging or discharging a capacitor ? Write the necessary expression to explain this observation.

18. तरंगाग्र शब्द की परिभाषा और हाइगेन्स सिद्धान्त लिखिए। 3
- किसी पतले उत्तल लेंस पर आपतित समतल तरंगाग्र पर विचार कीजिए। निर्गत तरंगाग्र की आवृत्ति दर्शाते हुए यह दर्शाने के लिए उपयुक्त आरेख खींचिए कि यह आपतित तरंगाग्र किस प्रकार लेंस में गमन करता है और अपवर्तन के पश्चात लेंस के फोकस बिन्दु पर फोकसित हो जाता है?

अथवा

कारण देते हुए निम्नलिखित की व्याख्या कीजिए :

- (i) जब एकवर्णी प्रकाश दो माध्यमों को पृथक करने वाले किसी पृष्ठ पर आपतन करता है, तो परावर्तित और अपवर्तित दोनों ही प्रकाशों की आवृत्ति आपतित प्रकाश की आवृत्ति के बराबर होती है।
- (ii) जब प्रकाश किसी विरल माध्यम से किसी सघन माध्यम में गमन करता है, तो प्रकाश की चाल घट जाती है। क्या चाल में कमी का यह अर्थ है कि तरंग द्वारा वहन की जाने वाली ऊर्जा घट गयी है?
- (iii) प्रकाश के तरंग चित्रण में प्रकाश की तीव्रता तरंग के आयाम के वर्ग द्वारा निर्धारित होती है। प्रकाश के फोटॉन चित्रण में तीव्रता कौन निर्धारित करता है?

Define the term wave front. State Huygen's principle.

Consider a plane wave front incident on a thin convex lens. Draw a proper diagram to show how the incident wave front traverses through the lens and after refraction focusses on the focal point of the lens, giving the shape of the emergent wave front.

OR

Explain the following, giving reasons :

- (i) When monochromatic light is incident on a surface separating two media, the reflected and refracted light both have the same frequency as the incident frequency.
- (ii) When light travels from a rarer to a denser medium, the speed decreases. Does this decrease in speed imply a reduction in the energy carried by the wave ?
- (iii) In the wave picture of light, intensity of light is determined by the square of the amplitude of the wave. What determines the intensity in the photon picture of light ?

19. (a) किसी रेडियोएक्टिव नाभिक द्वारा β^+ उत्सर्जन में सम्मिलित नाभिकीय मूल प्रक्रिया को प्रतीकात्मक रूप में लिखिए। 3

(b) नीचे दी गयी अभिक्रियाओं में

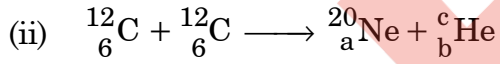
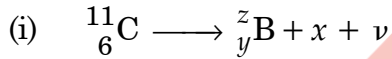

$x, y,$ और z तथा a, b और c के मान ज्ञात कीजिए।

(a) Write the basic nuclear process involved in the emission of β^+ in a symbolic form, by a radioactive nucleus.

(b) In the reactions given below :

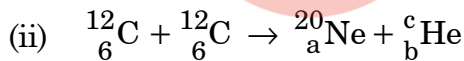

Find the values of $x, y,$ and z and a, b and c .

20. बायो-सावर्ट नियम का उपयोग करके R त्रिज्या के धारावाही पाश के अक्ष पर चुम्बकीय क्षेत्र के लिए व्यंजक व्युत्पन्न कीजिए। किसी वृत्ताकार तार, जिससे धारा I प्रवाहित हो रही है, के कारण चुम्बकीय क्षेत्र रेखाएं खींचिए। 3

Use Biot-Savart law to derive the expression for the magnetic field on the axis of a current carrying circular loop of radius R.

Draw the magnetic field lines due to a circular wire carrying current I.

21. (i) मुक्त इलेक्ट्रॉनों के अपवाह वेग के लिए व्यंजक व्युत्पन्न कीजिए। 3
(ii) किसी धात्विक चालक में इलेक्ट्रॉनों का अपवाह वेग ताप में वृद्धि के साथ किस प्रकार परिवर्तित होता है? व्याख्या कीजिए।
(i) Derive an expression for drift velocity of free electrons.
(ii) How does drift velocity of electrons in a metallic conductor vary with increase in temperature? Explain.
22. समविभव पृष्ठ की परिभाषा लिखिए। समविभव पृष्ठ के आरेख खींचिए : 3
(i) एकल बिन्दु आवेश, तथा
(ii) Z-दिशा में नियत विद्युत क्षेत्र के प्रकरणों के लिए समविभव पृष्ठ खींचिए। एकल आवेश के परितः समविभव पृष्ठ समदूरस्थ क्यों नहीं हैं?
(iii) क्या किसी समविभव पृष्ठ के स्पर्शरेखीय कोई विद्युत क्षेत्र हो सकता है? कारण दीजिए।
Define an equipotential surface. Draw equipotential surfaces :
(i) in the case of a single point charge and
(ii) in a constant electric field in Z-direction.
Why the equipotential surfaces about a single charge are not equidistant?
(iii) Can electric field exist tangential to an equipotential surface? Give reason.

खण्ड - द

SECTION - D

23. राम अपने गाँव के निकट के एक स्कूल में कक्षा X का छात्र है। उसके चाचा जी ने उसे एक साइकिल उपहार में दी जिसमें डायनमो लगा था। वह इस साइकिल को पाकर अत्यन्त उत्तेजित था। रात्रि के समय साइकिल चलाते समय वह बल्ब जलाकर सड़क की वस्तुओं को देख सकता था। परन्तु उसे इस युक्ति की क्रियाविधि का ज्ञान नहीं था। उसने इस बारे में अपने शिक्षक महोदय से पूछा। शिक्षक महोदय ने इसे डायनमो की क्रियाविधि को समस्त कक्षा को समझाने का एक अच्छा अवसर माना।
नीचे दिए गए प्रश्नों का उत्तर दीजिए :
(a) डायनमो की क्रियाविधि का सिद्धान्त लिखिए।
(b) राम और उसके शिक्षक महोदय द्वारा दर्शाए गए प्रत्येक के दो-दो मूल्यों का उल्लेख कीजिए। 4

Ram is a student of class X in a village school. His uncle gifted him a bicycle with a dynamo fitted in it. He was very excited to get it. While cycling during night, he could light the bulb and see the objects on the road. He, however, did not know how this device works. He asked this question to his teacher. The teacher considered it an opportunity to explain the working to the whole class.

Answer the following questions :

- State the principle and working of a dynamo.
- Write two values each displayed by Ram and his school teacher.

खण्ड - य

SECTION - E

24. (i) गाउस के नियम का उपयोग करके एकसमान आवेशित अनन्त समतल चादर के कारण विद्युत क्षेत्र ज्ञात कीजिए। धनात्मक और ऋणात्मक आवेश घनत्वों के लिए क्षेत्र की दिशा क्या होती है? 5
- (ii) दो संधारित्रों C_1 और C_2 , जिनकी धारिताओं का अनुपात 1 : 2 है, के श्रेणी और पार्श्व संयोजनों पर अनुप्रयुक्त विभवान्तर का वह अनुपात ज्ञात कीजिए जिसके द्वारा दोनों प्रकरणों में संचित ऊर्जा समान हो।
- अथवा**
- (i) यदि दो समान बड़ी पट्टिकाएं, जिनके क्षेत्रफल A तथा पृष्ठीय आवेश घनत्व $+\sigma$ और $-\sigma$ हैं, वायु में एक दूसरे से d दूरी पर हैं, तो निम्नलिखित के लिए व्यंजक प्राप्त कीजिए :
- पट्टिकाओं के बीच के किसी बिन्दु पर तथा पट्टिकाओं से बाहर किसी बिन्दु पर विद्युत क्षेत्र। प्रत्येक प्रकरण में क्षेत्र की दिशा का वर्णन भी कीजिए।
 - पट्टिकाओं के बीच विभवान्तर
 - इस प्रकार निर्मित संधारित्र की धारिता ज्ञात कीजिए।
- (ii) R और 2R त्रिज्याओं के दो धातुई गोलों को इस प्रकार आवेशित किया गया है, कि दोनों का पृष्ठीय आवेश घनत्व σ है। यदि दोनों को किसी चालक तार से संयोजित कर दिया जाए, तो आवेश किस दिशा में प्रवाहित होगा और क्यों?

- (i) Use Gauss's law to find the electric field due to a uniformly charged infinite plane sheet. What is the direction of field for positive and negative charge densities ?
- (ii) Find the ratio of the potential differences that must be applied across the parallel and series combination of two capacitors C_1 and C_2 with their capacitances in the ratio 1 : 2 so that the energy stored in the two cases becomes the same.

OR

- (i) If two similar large plates, each of area A having surface charge densities $+\sigma$ and $-\sigma$ are separated by a distance d in air, find the expressions for
- (a) field at points between the two plates and on outer side of the plates. Specify the direction of the field in each case.
- (b) the potential difference between the plates.
- (c) the capacitance of the capacitor so formed.
- (ii) Two metallic spheres of radii R and $2R$ are charged so that both of these have same surface charge density σ . If they are connected to each other with a conducting wire, in which direction will the charge flow and why ?

25. (i) अपचायी ट्रांसफॉर्मर का नामांकित आरेख खींचिए। इसकी क्रिया विधि के सिद्धान्त का उल्लेख कीजिए। 5
- (ii) वोल्टताओं को फेरा-अनुपात में व्यक्त कीजिए।
- (iii) किसी आदर्श ट्रांसफॉर्मर के लिए फेरा-अनुपात के पदों में प्राथमिक और द्वितीयक धाराओं का अनुपात ज्ञात कीजिए।
- (iv) 220 V आपूर्ति से किसी ट्रांसफॉर्मर की प्राथमिक कुण्डली द्वारा उस समय कितनी धारा ली जाती है, जब यह 110 V – 550 W के किसी रेफ्रिजरेटर को शक्ति प्रदान करता है ?

अथवा

- (a) एक दूसरे के निकट स्थित दो सोलेनॉयडों के अन्योन्य प्रेरकत्व से क्या तात्पर्य है ? इसकी व्याख्या कीजिए। r_1 तथा r_2 ($r_1 < r_2$) त्रिज्याओं की दो सकेन्द्री वृत्ताकार कुण्डलियों पर विचार कीजिए जो समाक्ष स्थित हैं तथा जिनके केन्द्र संपाती हैं। इस व्यवस्था के लिए अन्योन्य प्रेरकत्व के लिए व्यंजक प्राप्त कीजिए।
- (b) क्षेत्रफल A और फेरों की संख्या N की कोई आयताकार कुण्डली किसी एकसमान चुम्बकीय क्षेत्र B , जो कुण्डली के अभिलम्बवत है, में ' f ' चक्कर प्रति सेकण्ड से घूर्णन करायी जाती है। यह सिद्ध कीजिए कि कुण्डली में प्रेरित अधिकतम emf का मान $2 \pi f NBA$ है।

- (i) Draw a labelled diagram of a step-down transformer. State the principle of its working.
- (ii) Express the turn ratio in terms of voltages.
- (iii) Find the ratio of primary and secondary currents in terms of turn ratio in an ideal transformer.
- (iv) How much current is drawn by the primary of a transformer connected to 220 V supply when it delivers power to a 110 V – 550 W refrigerator ?

OR

- (a) Explain the meaning of the term mutual inductance. Consider two concentric circular coils, one of radius r_1 and the other of radius r_2 ($r_1 < r_2$) placed coaxially with centres coinciding with each other. Obtain the expression for the mutual inductance of the arrangement.
- (b) A rectangular coil of area A, having number of turns N is rotated at 'f' revolutions per second in a uniform magnetic field B, the field being perpendicular to the coil. Prove that the maximum emf induced in the coil is $2 \pi f NBA$.

26. (i) उत्तल गोलीय पृष्ठ पर अपवर्तन के लिए n_1 तथा n_2 के अपवर्तनांक तथा R वक्रता त्रिज्या के गोलीय पृष्ठ के बीच सम्बन्ध के लिए सूत्र व्युत्पन्न कीजिए। यह मानते हुए कि बिम्ब बिन्दुकित है और n_1 अपवर्तनांक के विरल माध्यम में मुख्य अक्ष पर स्थित है तथा वास्तविक प्रतिबिम्ब n_2 अपवर्तनांक के सघन माध्यम में बनता है, लेंस मेकर सूत्र व्युत्पन्न कीजिए। 5
- (ii) वायु में स्थित किसी बिन्दुकित बिम्ब से प्रकाश 20 cm वक्रता त्रिज्या और 1.5 अपवर्तनांक के किसी उत्तल गोलीय लेंस पर आपतन करता है। कांच के पृष्ठ से प्रकाश स्रोत की दूरी 100 cm है। प्रतिबिम्ब की स्थिति ज्ञात कीजिए।

अथवा

- (a) सामान्य समायोजन में किसी खगोलीय दूरदर्शक द्वारा वास्तविक प्रतिबिम्ब प्राप्त करने के लिए नामांकित किरण आरेख खींचिए। इसकी आवर्धन क्षमता की परिभाषा लिखिए।
- (b) आपको 0.5 D, 4 D और 10 D के तीन लेंस दूरदर्शक बनाने के लिए दिए गए हैं।
 - (i) इनमें से किन लेंसों का उपयोग अभिदृश्यक और नेत्रिका के लिए किया जाना चाहिए? अपने उत्तर की पुष्टि के लिए कारण दीजिए।
 - (ii) अभिदृश्यक के लिए बड़े द्वारक को प्रायिकता क्यों दी जाती है?

- (i) Derive the mathematical relation between refractive indices n_1 and n_2 of two media and radius of curvature R for refraction at a convex spherical surface. Consider the object to be a point lying on the principal axis in the rarer medium of refractive index n_1 and a real image formed in the denser medium of refractive index n_2 . Hence, derive the lens maker's formula.
- (ii) Light from a point source in air falls on a convex spherical glass surface of refractive index 1.5 and radius of curvature 20 cm. The distance of the light source from the glass surface is 100 cm. At what position is the image formed?

OR

- (a) Draw a labelled ray diagram to obtain the real image formed by an astronomical telescope in normal adjustment position. Define its magnifying power.
- (b) You are given three lenses of power 0.5 D, 4 D and 10 D to design a telescope.
 - (i) Which lenses should be used as objective and eyepiece? Justify your answer.
 - (ii) Why is the aperture of the objective preferred to be large?

Q. No.	Expected Answer / Value Points	Marks	Total Marks						
SECTION-A									
SET1,Q1 SET2,Q4 SET3,Q5	No work is done / $W = qV_{AB} = q \times 0 = 0$	1	1						
SET1,Q2 SET2,Q1 SET3,Q3	A diamagnetic specimen would move towards the weaker region of the field while a paramagnetic specimen would move towards the stronger region./ A diamagnetic specimen is repelled by a magnet while a paramagnetic specimen moves towards the magnet./ The paramagnetic get aligned along B and the diagrammatic perpendicular to the field.	1	1						
SET1,Q3 SET2,Q5 SET3,Q2	Transmitter, Medium or Channel and Receiver.	1	1						
SET1,Q4 SET2,Q3 SET3,Q1 .	It is due to least scattering of red light as it has the longest wavelength/ As per Rayleigh's scattering, the amount of light scattered $\propto \frac{1}{\lambda^4}$	1	1						
SET1,Q5 SET2,Q2 SET3,Q4	$E = 2V$ $r = 2\Omega$	½ ½	1						
SECTION B									
SET1,Q6 SET2,Q9 SET3,Q8.	<table border="1" style="width: 100%; border-collapse: collapse;"> <tr> <td>Definition-</td> <td align="right">1</td> </tr> <tr> <td>Reason-</td> <td align="right">½</td> </tr> <tr> <td>Role of bandpass filter-</td> <td align="right">½</td> </tr> </table> <p>Modulation index is the ratio of the amplitude of modulating signal to that of carrier wave</p> <p>Alternatively $\mu = \frac{A_m}{A_c}$</p> <p>Reason- To avoid distortion.</p> <p>Role- A bandpass filter rejects low and high frequencies and allows a band of frequencies to pass through.</p>	Definition-	1	Reason-	½	Role of bandpass filter-	½	1 ½ ½	2
Definition-	1								
Reason-	½								
Role of bandpass filter-	½								

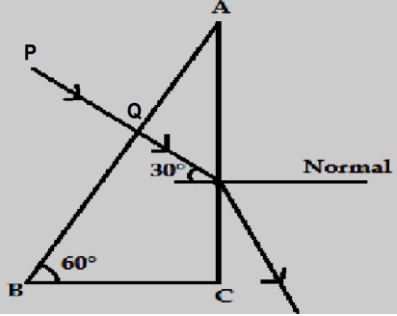
SET1,Q7 SET2,Q10 SET3,Q6	<div style="border: 1px solid black; padding: 5px; margin-bottom: 10px;"> <table style="width: 100%; border-collapse: collapse;"> <tr> <td style="padding: 2px;">Path of emergent ray</td> <td align="right" style="padding: 2px;">1</td> </tr> <tr> <td style="padding: 2px;">Naming the face</td> <td align="right" style="padding: 2px;">½</td> </tr> <tr> <td style="padding: 2px;">Justification</td> <td align="right" style="padding: 2px;">½</td> </tr> </table> </div> <div style="text-align: center; margin-bottom: 10px;">  </div> <p>Face-AC</p> <p>Here $i_c = \sin^{-1}(\frac{2}{3})$ $= \sin^{-1}(0.6)$</p> <p>$\angle i$ on face AC is 30° which is less than $\angle i_c$. Hence the ray get replaced here.</p>	Path of emergent ray	1	Naming the face	½	Justification	½	1	2
Path of emergent ray	1								
Naming the face	½								
Justification	½								
SET1,Q8 SET2,Q6 SET3,Q7	<div style="border: 1px solid black; padding: 5px; margin-bottom: 10px;"> <table style="width: 100%; border-collapse: collapse;"> <tr> <td style="padding: 2px;">Formulae of Kinetic energy and deBrogliea wavelength</td> <td align="right" style="padding: 2px;">½ +½</td> </tr> <tr> <td style="padding: 2px;">Calculation and Result</td> <td align="right" style="padding: 2px;">½+½</td> </tr> </table> </div> <p>Kinetic Energy for the second state-</p> $E_k = \frac{13.6eV}{n^2} = \frac{13.6eV}{4} = 3.4 \times 1.6 \times 10^{-19} J$ <p>De Broglies wavelength $\lambda = \frac{h}{\sqrt{2mE_k}}$</p> $= \frac{6.63 \times 10^{-34}}{\sqrt{2 \times 9.1 \times 10^{-31} \times 3.4 \times 1.6 \times 10^{-19}}}$ <p>$= 0.067 \text{ nm}$</p>	Formulae of Kinetic energy and deBrogliea wavelength	½ +½	Calculation and Result	½+½	½ ½ ½	2		
Formulae of Kinetic energy and deBrogliea wavelength	½ +½								
Calculation and Result	½+½								
SET1,Q9 SET2,Q8 SET3,Q10	<div style="border: 1px solid black; padding: 5px; margin-bottom: 10px;"> <table style="width: 100%; border-collapse: collapse;"> <tr> <td style="padding: 2px;">Definition</td> <td align="right" style="padding: 2px;">1</td> </tr> <tr> <td style="padding: 2px;">Formula</td> <td align="right" style="padding: 2px;">½</td> </tr> <tr> <td style="padding: 2px;">Calculation and Result</td> <td align="right" style="padding: 2px;">½</td> </tr> </table> </div> <p>The minimum energy, required to free the electron from the ground state of the hydrogen atom, is known as Ionization Energy.</p>	Definition	1	Formula	½	Calculation and Result	½	1	
Definition	1								
Formula	½								
Calculation and Result	½								

	$E_o = \frac{me^4}{8\epsilon_o^2 h^2} \text{ i.e., } E_o \propto m$ <p>Therefore, Ionization Energy will become 200 times</p> <p align="center">OR</p> <table border="1" style="margin-left: auto; margin-right: auto;"> <tr> <td>Formula</td> <td align="right">1</td> </tr> <tr> <td>Calculation and Result</td> <td align="right">1/2+1/2</td> </tr> </table> $\frac{1}{\lambda} = R \left(\frac{1}{2^2} - \frac{1}{\infty^2} \right)$ <p>For shortest wavelength, $n = \infty$</p> <p>Therefore, $\frac{1}{\lambda} = \frac{R}{4} \Rightarrow \lambda = \frac{4}{R} = 4 \times 10^{-7} \text{ m}$</p>	Formula	1	Calculation and Result	1/2+1/2	<p align="center">1/2</p> <p align="center">1/2</p> <p align="center">1</p> <p align="center">1/2</p> <p align="center">1/2</p>	<p align="center">2</p> <p align="center">2</p>				
Formula	1										
Calculation and Result	1/2+1/2										
<p>SET1,Q10 SET2,Q7 SET3,Q9</p>	<table border="1" style="margin-left: auto; margin-right: auto;"> <tr> <td>a) Relation for terminal potential</td> <td align="right">1/2</td> </tr> <tr> <td>b) Justification</td> <td align="right">1/2</td> </tr> <tr> <td>c) Explanation (parallel and series)</td> <td align="right">1/2 + 1/2</td> </tr> </table> <p>a) Effective resistance of the circuit $R_E = 6\Omega$ $\therefore I = \frac{12A}{6} = 2A$</p> <p>Terminal potential difference across the cell, $V = E - ir$</p> <p>Also p.d. across 4Ω resistor $= 4 \times 2V = 8V$ Hence the voltmeter gives the same reading in the two cases.</p> <p>b) In series -current same In parallel – potential same</p>	a) Relation for terminal potential	1/2	b) Justification	1/2	c) Explanation (parallel and series)	1/2 + 1/2	<p align="center">1/2</p> <p align="center">1/2</p> <p align="center">1/2</p> <p align="center">1/2</p>	<p align="center">2</p>		
a) Relation for terminal potential	1/2										
b) Justification	1/2										
c) Explanation (parallel and series)	1/2 + 1/2										
SECTION C											
<p>SET1,Q11 SET2,Q15 SET3,Q22</p>	<table border="1" style="margin-left: auto; margin-right: auto;"> <tr> <td>Definition-</td> <td align="right">1/2</td> </tr> <tr> <td>i. Diagram of Equipotential Surface</td> <td align="right">1/2</td> </tr> <tr> <td>ii. Diagram and reason</td> <td align="right">1/2 + 1/2</td> </tr> <tr> <td>iii. Answer and Reason</td> <td align="right">1/2 + 1/2</td> </tr> </table> <p>Surface with a constant value of potential at all points on the surface.</p>	Definition-	1/2	i. Diagram of Equipotential Surface	1/2	ii. Diagram and reason	1/2 + 1/2	iii. Answer and Reason	1/2 + 1/2	<p align="center">1/2</p>	
Definition-	1/2										
i. Diagram of Equipotential Surface	1/2										
ii. Diagram and reason	1/2 + 1/2										
iii. Answer and Reason	1/2 + 1/2										

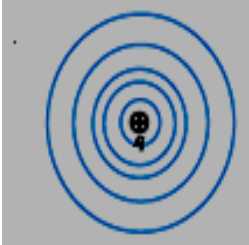
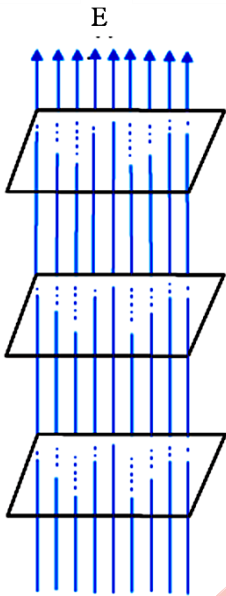
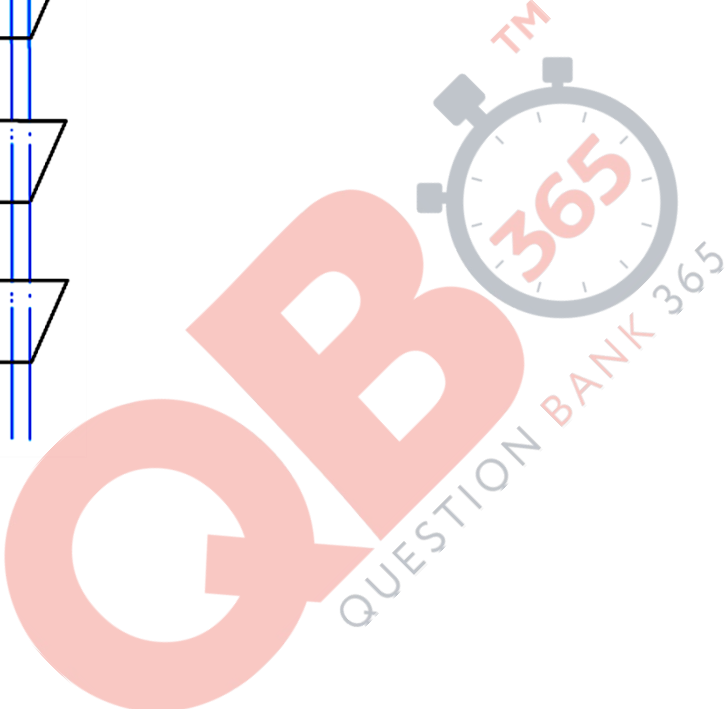
<p>i.</p>   <p>ii.</p> <p>$V \propto \frac{1}{r}$</p> <p>iii.No</p> <p>If the field lines are tangential, work will be done in moving a charge on the surface which goes against the definition of equipotential surface.</p>	<p align="center">  </p>	<p align="center">1/2</p> <p align="center">1/2</p> <p align="center">1/2</p> <p align="center">1/2</p>	<p align="center">3</p>						
<p>SET1,Q12 SET2,Q14 SET3,Q12</p>	<table border="1" data-bbox="235 1516 1133 1654"> <tr> <td>Statement</td> <td align="right">1</td> </tr> <tr> <td>Plotting the graph</td> <td align="right">1</td> </tr> <tr> <td>Calculating value of (μ)refractive index</td> <td align="right">1</td> </tr> </table> <p>i. When the pass axis of a polaroid makes an angle θ with the plane of polarisation of polarised light of intensity I_0 incident on it, then the intensity of the transmitted emergent light is given by $I = I_0 \cos^2 \theta$</p> <p>Note: If the student writes the formula $I = I_0 \cos^2 \theta$ and draws the</p>	Statement	1	Plotting the graph	1	Calculating value of (μ)refractive index	1	<p align="center">1</p>	
Statement	1								
Plotting the graph	1								
Calculating value of (μ)refractive index	1								

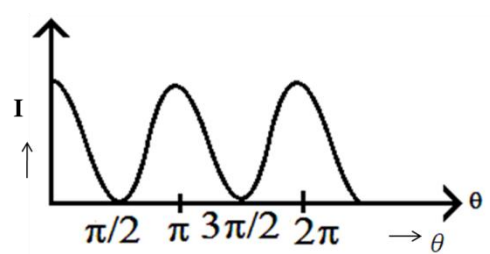
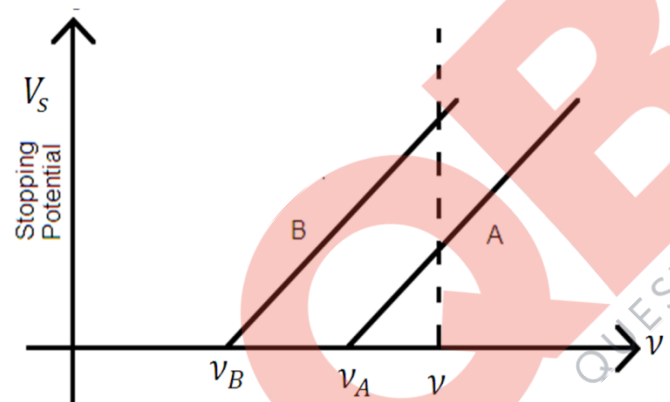
	<p>diagram give 1mark.</p> <p>i.</p>  <p>iii. $\mu = \tan i_B$ $= \tan 60^\circ = \sqrt{3} = 1.7$</p>	<p>1</p> <p>1/2 1/2</p>	<p>3</p>
<p>SET1,Q13 SET2,Q13 SET3,Q14</p>	<div style="border: 1px solid black; padding: 5px; margin-bottom: 10px;"> <p align="right">1</p> <p>Sketch of the Graph</p> <p>(i) Stopping Potential and Reason 1/2+ 1/2</p> <p>(ii) Dependence of Slope and Explanation 1/2+ 1/2</p> </div>  <p>(i) For material B From the graph for the same value of ' ν ', stopping potential is more for material 'B' $[V_0 = \frac{h}{e}(\nu - \nu_0)]$ \therefore, V_0 is higher for lower value of ν_0</p> <p>(ii) No As slope is given by $\frac{h}{e}$ which is constant.</p>	<p>1</p> <p>1/2 1/2 1/2</p>	<p>3</p>

	<p>i) $P_{av} = I_{av} \times e_{av} \cos \phi$</p> <p>For an ideal inductor, $\phi = \frac{\pi}{2}$</p> <p>$\therefore P_{av} = I_{av} \times e_{av} \cos \frac{\pi}{2}$</p> <p>$P_{av} = 0$</p> <p>ii) Brightness decreases</p> <p>Because as iron rod is inserted inductance increases. Thus, current decreases and brightness decreases.</p>	<p>1/2</p> <p>1/2</p> <p>1/2</p> <p>1/2</p> <p>1/2</p> <p>1/2</p>	<p>3</p>
<p>SET1,Q17 SET2,Q21 SET3,Q16</p>	<div data-bbox="298 657 1138 898" style="border: 1px solid black; padding: 5px;"> <p>i. Diagram of Formation 1/2</p> <p>Explanation of formation of Depletion region 1/2</p> <p>Barrier potential 1/2</p> <p>ii. Circuit diagram of Half wave rectifier 1/2</p> <p>Explanation 1</p> </div> <div data-bbox="298 978 751 1457" style="text-align: center;"> <p>The diagram (a) shows a cross-section of a PN junction. The p-region is on the left and the n-region is on the right. A depletion region is formed at the junction, containing positive ions on the p-side and negative ions on the n-side. An electric field E points from the n-region to the p-region. A width 'w' is indicated for the depletion region. Below the diagram is a graph of the potential barrier V_s, showing a step-like increase across the junction.</p> </div> <p>i.</p> <p>ii.</p> <p>i. Due to diffusion and drift, the electrons and holes move across the junctions, creating a final stage in which a region is created across the junction wall, which gets devoid of the mobile charge carriers. This region is called depletion region; the potential difference across the region is called Barrier potential</p>	<p>1/2</p> <p>1/2+1/2</p>	

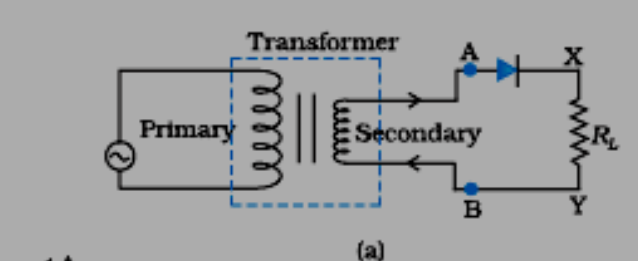
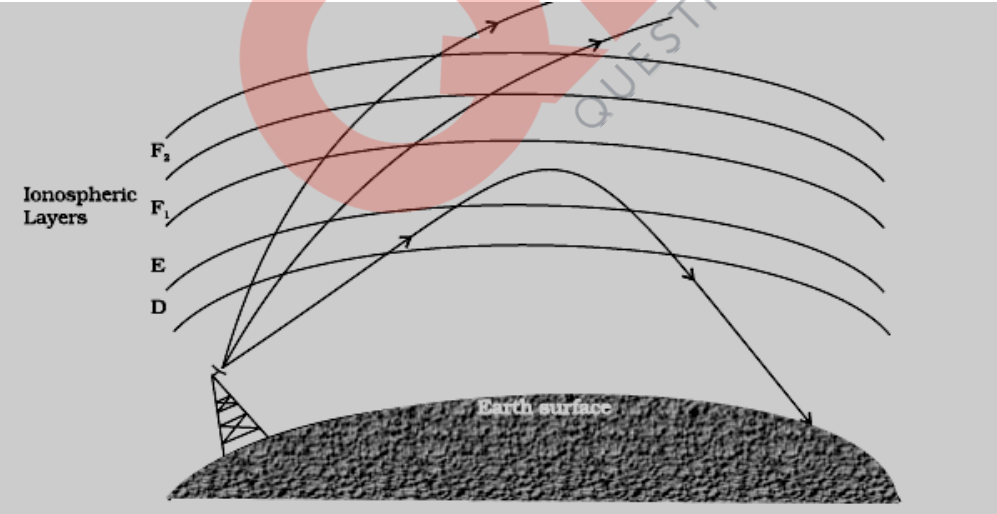
	 <p>Working- If an alternating voltage is applied across a diode in series with a load, a pulsating voltage will appear across the load only during that half cycle of the ac input during which the diode is forward biased.</p> <p>Therefore, in the positive half – cycle of ac input there is a current through the load resistor R_L and we get an output voltage whereas half – cycle. There is no output during the negative half cycle. Thus, the output voltage is restricted to only one direction and is said to be rectified.</p> <p>[Note-If the student draws only the input and output wave form, then award $\frac{1}{2}$ marks only]</p>	<p>$\frac{1}{2}$</p> <p>$\frac{1}{2}$</p> <p>$\frac{1}{2}$</p>	<p>3</p>								
<p>SET1,Q18 SET2,Q20 SET3,Q13</p>	<table border="1" data-bbox="240 898 1154 1066"> <tr> <td>a) Mode of propagation</td> <td>$\frac{1}{2}$</td> </tr> <tr> <td>Labeled diagram</td> <td>1</td> </tr> <tr> <td>Explanation</td> <td>$\frac{1}{2}$</td> </tr> <tr> <td>b) Reason</td> <td>1</td> </tr> </table> <p>a) Sky wave propagation</p>  <p>Long distance communication can be achieved by reflection of radio waves by the ionosphere, back towards the Earth. This ionosphere layer acts as a reflector only for a certain range of frequencies.(fewMHz to 30MHz)</p> <p>b) Electromagnetic waves of frequencies higher than 30MHz, penetrate the ionosphere and escape whereas the waves less than 30MHz are</p>	a) Mode of propagation	$\frac{1}{2}$	Labeled diagram	1	Explanation	$\frac{1}{2}$	b) Reason	1	<p>$\frac{1}{2}$</p> <p>1</p> <p>$\frac{1}{2}$</p> <p>1</p>	<p>3</p>
a) Mode of propagation	$\frac{1}{2}$										
Labeled diagram	1										
Explanation	$\frac{1}{2}$										
b) Reason	1										

	reflected back to the earth by the ionosphere.										
SET1,Q19 SET2,Q19 SET3,Q17	<table border="1"> <tr> <td>i. Identification</td> <td>1+1</td> </tr> <tr> <td>ii. Momentary deflection of galvanometer</td> <td></td> </tr> <tr> <td>Reason</td> <td>½</td> </tr> <tr> <td>Expressions</td> <td>½</td> </tr> </table> <p>i. a. Microwaves b. X-rays</p> <p>ii Due to conduction current in the connecting wires and a displacement current between the plates</p> $I_d = \epsilon_0 \frac{d\phi_E}{dt}$	i. Identification	1+1	ii. Momentary deflection of galvanometer		Reason	½	Expressions	½	1 1 ½ ½	3
i. Identification	1+1										
ii. Momentary deflection of galvanometer											
Reason	½										
Expressions	½										
SET1,Q20 SET2,Q18 SET3,Q11	<table border="1"> <tr> <td>i. Collection current</td> <td>½ +½</td> </tr> <tr> <td>ii. Base Current</td> <td>½ +½</td> </tr> <tr> <td>iii. Base voltage</td> <td>½ +½</td> </tr> </table> <p>i. Input signal Voltage</p> <p>AC Collector Current- $i_c = \frac{V_{ce}}{R_c} = 1.0mA$</p> <p>Base Current- $i_b = \frac{i_c}{\beta} = \frac{1.0mA}{100} = 0.01mA$</p> <p>Base signal Voltage= $i_b R = 0.01mA \times 1k\Omega = 10mv$</p>	i. Collection current	½ +½	ii. Base Current	½ +½	iii. Base voltage	½ +½	½ +½ ½ +½ ½ +½	3		
i. Collection current	½ +½										
ii. Base Current	½ +½										
iii. Base voltage	½ +½										

SET1,Q21
SET2,Q17
SET3,Q18

Definition- wave front	1
Statement- Huygen's Principle	1
Labelled diagram	1

Definition- Locus of all points which oscillate in phase.

1

i. Huygen's Principle- Each point of the wave front is the source of a secondary disturbance and the wavelets emanating from these points spread out in all directions. These travel with the same velocity as that of the original wave front.

1/2

ii. The shape and position of the wave front, after time 't', is given by the tangential envelope to the secondary wavelets.

1/2

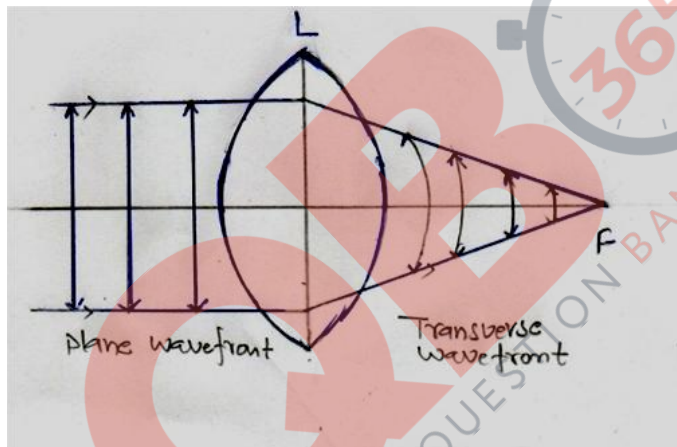

1/2 + 1/2 3

OR

i. Reason for no change in frequency after reflection and the refraction of light-	1/2+1/2
ii. Reduction in Energy	1
iii. Factors determining the intensity of light	1

i. Reflection and refraction arise through interaction of incident light with atomic constituents of matter which vibrate with the same frequency as that of the incident light. Hence frequency remains unchanged.

ii.No. [Energy carried by a wave depends on the amplitude of the wave, not on the speed of wave propagation].

iii.For a given frequency, intensity of light in the photon picture is

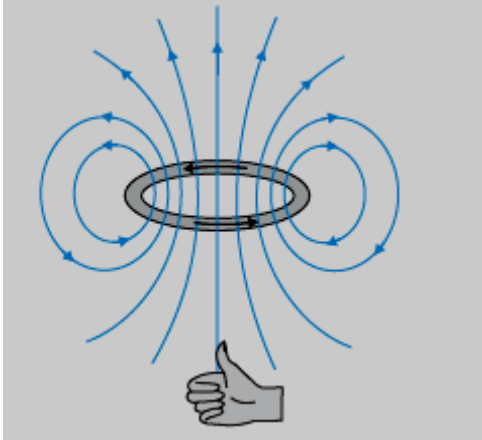
		1	3		
SECTION D					
SET1,Q23 SET2,Q23 SET3,Q23	<table border="1" style="width: 100%; border-collapse: collapse;"> <tr> <td style="width: 50%; padding: 5px;"> a. Principle and working b. Two values, each, displayed by i. Ram ii. School teacher </td> <td style="width: 50%; padding: 5px; text-align: right;"> 1+1 ½+½ ½+½ </td> </tr> </table> <p style="margin-top: 10px;">a. Principle: Whenever a coil is rotated in a magnetic field, an emf is induced in it due to the change in magnetic flux linked with it.</p> <p>Working- As the coil rotates, its inclination (θ) with respect to the field changes. Hence sinusoidal /varying emf(=$e_0 \sin \omega t$) is obtained./May also be explained graphically.</p> <p>[Note- Give full marks if the student obtains the expression for induced emf mathematically.]</p> <p>b. Values Ram- Scientific aptitude, curiosity, keenness to learn, positive approach, etc(any two)</p> <p>Teacher- Dedication, concern for students, depth of knowledge, generous, positive attitude towards queries, motivational approach.(any two)</p>	a. Principle and working b. Two values, each, displayed by i. Ram ii. School teacher	1+1 ½+½ ½+½	1	3
a. Principle and working b. Two values, each, displayed by i. Ram ii. School teacher	1+1 ½+½ ½+½				

	SECTION E																
SET1,Q24 SET2,Q26 SET3,Q25	<table border="1" style="width: 100%; border-collapse: collapse;"> <tr> <td style="width: 60%;">i. Labelled diagram</td> <td align="right">1</td> </tr> <tr> <td style="padding-left: 20px;">Principle</td> <td align="right">1</td> </tr> <tr> <td>ii. Expression for the turn ratio in terms of voltage</td> <td align="right">½</td> </tr> <tr> <td>iii. Ratio of primary and secondary currents in terms of turns</td> <td align="right">1</td> </tr> <tr> <td>iv. Current drawn by primary</td> <td></td> </tr> <tr> <td style="padding-left: 20px;">Formula-</td> <td align="right">½</td> </tr> <tr> <td style="padding-left: 20px;">Calculation and result</td> <td align="right">½ +½</td> </tr> </table> <p style="margin-top: 20px;">i. Labelled diagram</p> <p align="center" style="margin-top: 20px;">SOFT IRON CORE</p>	i. Labelled diagram	1	Principle	1	ii. Expression for the turn ratio in terms of voltage	½	iii. Ratio of primary and secondary currents in terms of turns	1	iv. Current drawn by primary		Formula-	½	Calculation and result	½ +½	1	
i. Labelled diagram	1																
Principle	1																
ii. Expression for the turn ratio in terms of voltage	½																
iii. Ratio of primary and secondary currents in terms of turns	1																
iv. Current drawn by primary																	
Formula-	½																
Calculation and result	½ +½																

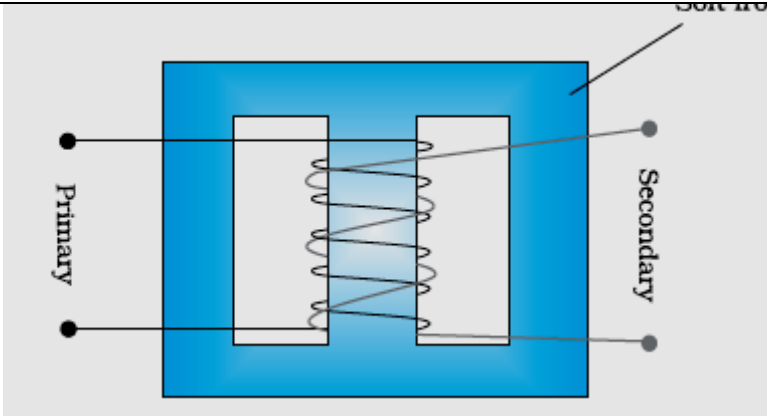

Principle-
When the current flowing through the primary coil changes, an emf is induced in the secondary coil due to the change in magnetic flux linked with it.

[Note- Give ½ mark to the student who writes only mutual induction only.]

ii. $\frac{V_s}{V_p} = \frac{N_s}{N_p}$

iii. For an ideal transformer,

$$i_p V_p = i_s V_s \therefore \frac{i_p}{i_s} = \frac{V_s}{V_p} = \frac{N_s}{N_p}$$

iv. We have

$$i_p V_p = i_s V_s = 550\text{w}$$

$$V_p = 220\text{V}$$

$$i_p = \frac{550}{220} = \frac{5}{2} = 2.5\text{A}$$

OR

a. Meaning of Mutual Inductance	1
Expression	1½
b. Proof	2
Diagram	½

a. Mutual Inductance is the property of a pair of coils due to which an emf induced in one of the coils due to the change in the current in the other coil.

1
1
1
½
½ + ½
½
½
5
1
½
½

Mathematically $e_2 = -\frac{M di_1}{dt}$

$\therefore M = -\frac{e_2}{di_1/dt}$

Let a current I_2 flow through the outer circular coil. Then

$B_2 = \mu I_2 / 2r_2$

$\therefore \Phi_1 = \pi r_1^2 B_2 = \frac{\mu \pi r_1^2}{2r_2} I_2 = M_{12} I_2$

Thus $M_{12} = \frac{\mu \pi r_1^2}{2r_2} = M_{21}$

b.

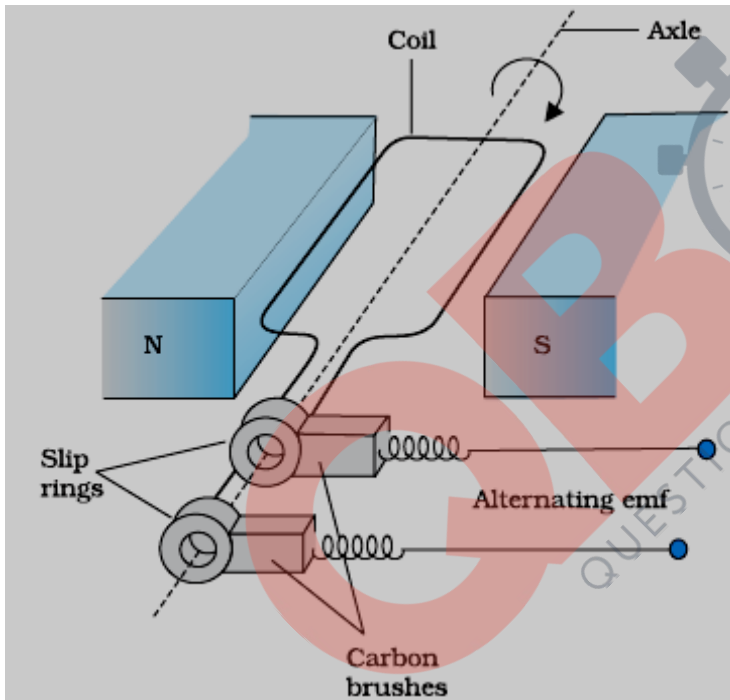

Flux at any time 't'.

$\Phi_B = BA \cos \theta = BA \cos \omega t$

From Faraday's Law, induced emf

$e = -N \frac{d\Phi_B}{dt} = NBA \frac{d}{dt} (\cos \omega t)$

Thus the instantaneous value of emf is

$E = NBA \omega \sin \omega t$

For maximum value of emf $\sin \omega t = \pm 1$

i.e, $e_0 = NBA \omega = 2\pi f NBA$

1/2

1/2

1/2

1/2

1/2

5

SET1,Q25
SET2,Q24
SET3,Q26
Q25.

i. Derivation of $\frac{n_2}{v} - \frac{n_1}{u} = \frac{(n_2 - n_1)}{R}$	1½
$\frac{1}{f} = \left(\frac{n_2 - n_1}{n_1}\right) \left(\frac{1}{R_1} - \frac{1}{R_2}\right)$	1½
ii. Formula	½
Calculation and result	1½

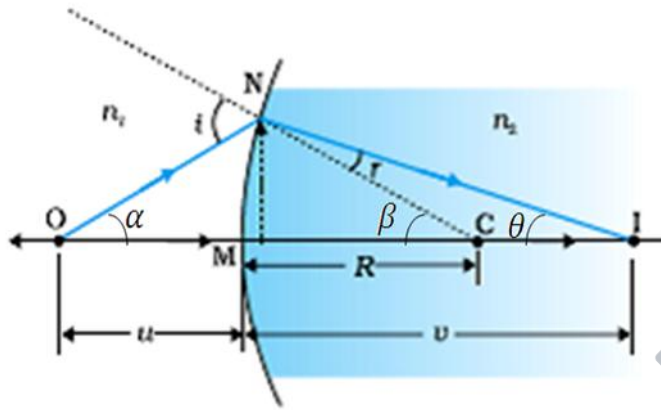

½

Ray diagram showing real image formation as per prescription

$$\theta_1 = \alpha + \beta$$

$$\theta_2 = \beta - \gamma \quad \therefore \gamma = \beta - \theta$$

½

For paraxial rays θ_1 and θ_2 are small

Therefore, $n_2 \sin \theta_2 = n_1 \sin \theta_1$ (Snells law)

Reduces to

$$\text{At N } \frac{\sin i}{\sin r} = \frac{n_2}{n_1}$$

$$\therefore n_1 = r \times n_2$$

$$(\alpha + \beta)n_1 = (\beta - \theta)n_2$$

$$n_1 \left(\frac{NM}{OM} + \frac{NM}{MC} \right) = \left(\frac{NM}{MC} - \frac{NM}{MI} \right) n_2$$

$$n_1 \left(\frac{1}{-u} + \frac{1}{+R} \right) = \left(\frac{1}{+R} - \frac{1}{u} \right) n_2$$

½

$$\frac{n_2}{v} - \frac{n_1}{u} = \frac{(n_2 - n_1)}{R_1}$$

1

Applying above relations to refraction through a lens

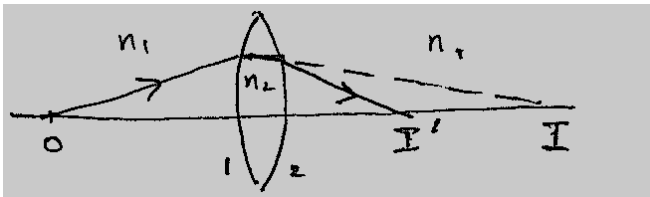

For surface 1

$$\frac{n_2 - n_1}{R_1} = \frac{n_2}{v'} - \frac{n_1}{u} \quad \dots(i)$$

For surface 2

$$\frac{n_1 - n_2}{R_2} = \frac{n_1}{v} - \frac{n_2}{v'} \quad \dots(ii)$$

Adding eqn. (i) and (ii)

$$(n_2 - n_1) \left(\frac{1}{R_1} - \frac{1}{R_2} \right) = n_1 \left(\frac{1}{v} - \frac{1}{u} \right)$$

For $u = \infty$ $v = f$

$$\therefore \frac{n_1}{f} = (n_2 - n_1) \left(\frac{1}{R_1} - \frac{1}{R_2} \right)$$

$$\Rightarrow \frac{1}{f} = \left(\frac{n_2}{n_1} - 1 \right) \left(\frac{1}{R_1} - \frac{1}{R_2} \right)$$

(iii) $R = 20 \text{ cm}$ $n_2 = 1.5$ $n_1 = 1$ $u = -100 \text{ cm}$

$$\frac{n_2}{v} = \frac{(n_2 - n_1)}{R} + \frac{n_1}{u}$$

$$= \frac{0.5}{20 \text{ cm}} - \frac{1}{100 \text{ cm}}$$

$$= \frac{1.5}{100} \text{ cm}$$

$\Rightarrow V = 100 \text{ cm}$ a real image on the other side, 100 cm away from the surface.

OR

a.	i. Labelled ray diagram of Astronomical Telescope	1½
	Definition of magnifying Prism	1
	ii. Identification of lenses	½+½
	Justification	½+½
	Reason	½

½

½

½

½

½

5

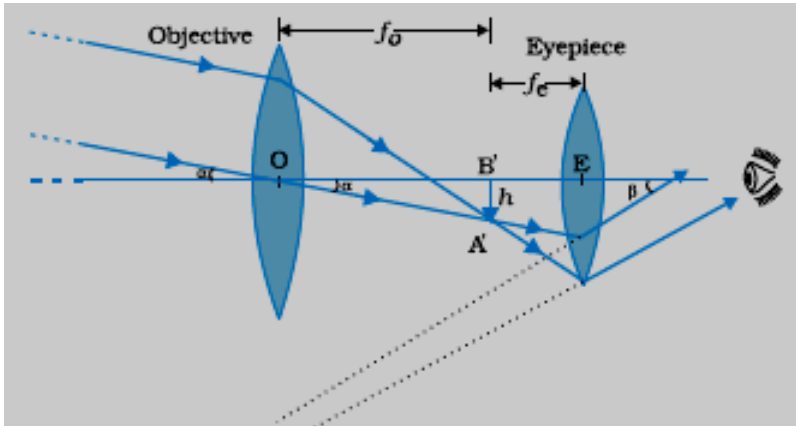

Definition-It is the ratio of the angle subtended at the eye, by the final image, to the angle which the object subtends at the lens, or the eye.

b.

i. Objective = 5D

Eye lens = 10D

This choice would give higher magnification as

$$M = \frac{f_o}{f_e} = \frac{P_e}{P_o}$$

ii. High resolving power/ Brighter image / lower limit of resolution (**any one**)

1½

1

½

½

½ + ½

½

5

SET1,Q26
SET2,Q25
SET3,Q24

i. Derivation for electric field due to infinite plane	
Sheet of charge	2
Directions of field	1/2+1/2
ii. Formula	1/2
Calculation and result	1 1/2

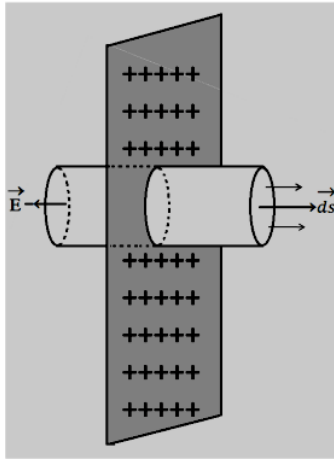

1/2

Symmetry of situation suggests that \vec{E} is perpendicular to the plane \Rightarrow Gaussian surface through P like a cylinder of flat caps parallel to the plane and one cap passing through P. the plane being the plane of symmetry for the Gaussian surface.

$$\oint \vec{E} \cdot d\vec{s} = \int_{\text{through caps}} \vec{E} \cdot d\vec{s}$$

1/2

$\vec{E} \perp d\vec{s}$ for all over curved surface and hence $\vec{E} \cdot d\vec{s} = 0$

$$\int_{\text{caps}} E ds = 2E\Delta s$$

Δs = area of each cap
By Gauss' law

$$\oint \vec{E} \cdot d\vec{s} = \frac{q}{\epsilon_0} = \frac{\sigma \Delta s}{\epsilon_0}$$

1/2

$$\therefore 2E\Delta s = \frac{\sigma \Delta s}{\epsilon_0}$$

$$E = \frac{\sigma}{2\epsilon_0}$$

1/2

If σ is positive \vec{E} points normally outwards/away from the sheet

1/2

If σ is (-)ve \vec{E} points normally inwards/towards the sheet

1/2

$$U_s = \frac{1}{2} C_s V_s^2$$

$$U_p = \frac{1}{2} C_p V_p^2$$

$$\Rightarrow \frac{V_{series}}{V_{parallel}} = \sqrt{\frac{C_{equivalent\ parallel}}{C_{equivalent\ series}}}$$

$$= \sqrt{\frac{\frac{C_1+C_2}{C_1 C_2}}{C_1+C_2}}$$

$$= \frac{C_1+C_2}{\sqrt{C_1 C_2}} = \frac{3}{\sqrt{2}}$$

1/2

1/2

1/2

1/2

OR

i. Deriving the expression for Field between the plate & outside	1/2 + 1/2
Direction of electric field inside and outside	1/2 + 1/2
Potential difference between the plates	1
Capacitance	1
ii. Direction of flow of charge	1/2 + 1/2

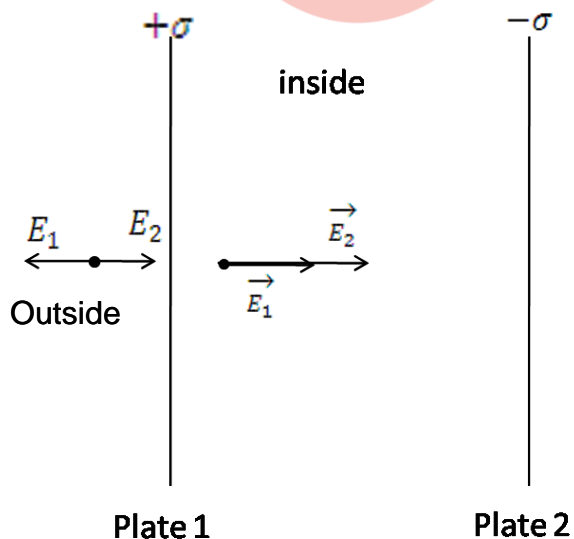

1/2 + 1/2

	<p>Inside $\rightarrow \rightarrow + \rightarrow$ $E = E_1 + E_2$</p> $\frac{\sigma + \sigma}{2\epsilon_0} = \frac{\sigma}{\epsilon_0}$ <p>Outside $\rightarrow \rightarrow \rightarrow$ $E = E_2 - E_1$</p> $= \frac{\sigma - \sigma}{2\epsilon_0} = 0$ <p>b. Potential difference between plates</p> $V = Ed = \frac{1}{\epsilon_0} \frac{Qd}{A}$ <p>c. Capacitance</p> $C = \frac{Q}{V} = \frac{\epsilon_0 A}{d}$ <p>ii. As potential on and inside a charged sphere is given</p> $V = \frac{1}{4\pi\epsilon_0} \frac{q}{r} = \frac{1}{4\pi\epsilon_0} \cdot \frac{4\pi r^2 \sigma}{r}$ <p>$\therefore, V \propto r$</p> <p>Hence, the bigger sphere will be at higher potential, so charge will flow from bigger sphere to smaller sphere.</p>	<p>$\frac{1}{2}$</p> <p>$\frac{1}{2} + \frac{1}{2}$</p> <p>$\frac{1}{2} + \frac{1}{2}$</p> <p>$\frac{1}{2}$</p> <p>$\frac{1}{2}$</p>	<p>5</p>
--	-------------------------------------------------------------------------------------------------------------------------------------------------------------------------------------------------------------------------------------------------------------------------------------------------------------------------------------------------------------------------------------------------------------------------------------------------------------------------------------------------------------------------------------------------------------------------------------------------------------------------------------------------------------------------------------------------------------------------------------------------------------------------------------------------------------------------------	---------------------------------------------------------------------------------------------------------------------------------------------------------------------------------------------	----------