

Very Short Answer Questions (PYQ)

Q. 1. Name the physical quantity whose SI unit is JC^{-1} . Is it a scalar or a vector quantity? [CBSE Delhi 2010]

Ans. Electric potential. It is a scalar quantity.

Q. 2. Figure shows the field lines on a positive charge. Is the work done by the field in moving a small positive charge from Q to P positive or negative? Give reason.

[CBSE (F) 2014]

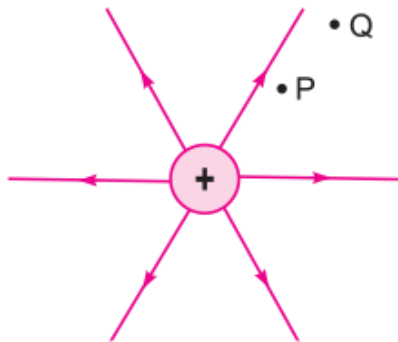

Ans. The work done by the field is negative. This is because the charge is moved against the force exerted by the field.

Q. 3. The field lines of a negative point charge are as shown in the figure. Does the kinetic energy of a small negative charge increase or decrease in going from B to A?

[CBSE Patna 2015]

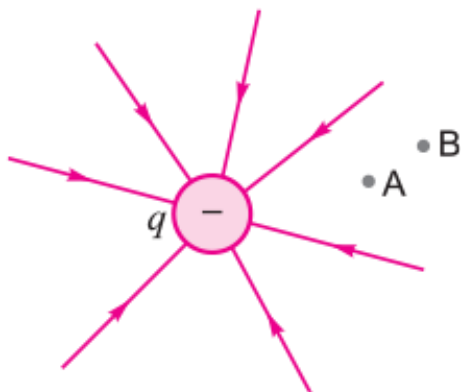

Ans. The kinetic energy of a negative charge decreases while going from point B to point A, against the movement of force of repulsion.

Q. 4. A point charge +Q is placed at point O as shown in the figure. Is the potential difference $V_A - V_B$ positive, negative or zero? [CBSE Delhi 2016]

Ans.



Ans. The potential due to a point charge decreases with increase of distance. So, $V_A - V_B$ is positive. Explanation: Let the distance of point A and B from charge Q be r_A and r_B respectively.

$$V_A = \frac{+Q}{4\pi\epsilon_0 r_A} \text{ and } V_B = \frac{+Q}{4\pi\epsilon_0 r_B}$$

$$V_A - V_B = \frac{+Q}{4\pi\epsilon_0} \left(\frac{1}{r_A} - \frac{1}{r_B} \right)$$

Also $r_A < r_B$

$$\Rightarrow \frac{1}{r_A} > \frac{1}{r_B} \Rightarrow \frac{1}{r_A} - \frac{1}{r_B} > 0 \Rightarrow \frac{1}{r_A} - \frac{1}{r_B} \text{ has positive value}$$

Also Q is positive.

Hence $V_A - V_B$ is positive.

Q. 5. A point charge Q is placed at point 'O' as shown in figure. Is the potential at point A, i.e., V_A , greater, smaller or equal to potential, V_B , at point B, when Q is (i) positive, and (ii) negative charge? [CBSE (F) 2017]

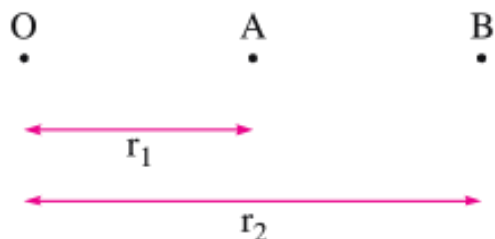

Ans.

i. If Q is positive,

$$V_A = \frac{kQ}{r_1} \quad \text{and} \quad V_B = \frac{kQ}{r_2}$$

Clearly, $V_A > V_B$

ii. If is negative,

$$V_A = \frac{kQ}{r_1} \quad \text{and} \quad V_B = \frac{kQ}{r_2}$$

Clearly, $V_A < V_B$

Q. 7. A $500 \mu\text{C}$ charge is at the centre of a square of side 10 cm. Find the work done in moving a charge of $10 \mu\text{C}$ between two diagonally opposite points on the square.

[CBSE Delhi 2008]

Ans.

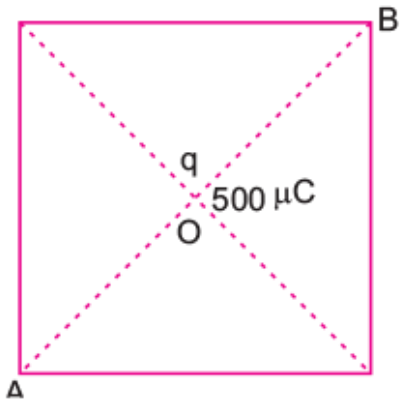

The points A and B are equidistant from the centre of square where charge $q = 500 \mu\text{C}$ is located; therefore, points A and B are at the same potential i.e., $V_A = V_B$.

\therefore Work done in moving charge $q_0 = 10 \mu\text{C}$ from A to B is

$$W = q_0 (V_B - V_A) = 0$$

Q. 7. Draw an equipotential surface in a uniform electric field. [CBSE (AI) 2008]

Ans.

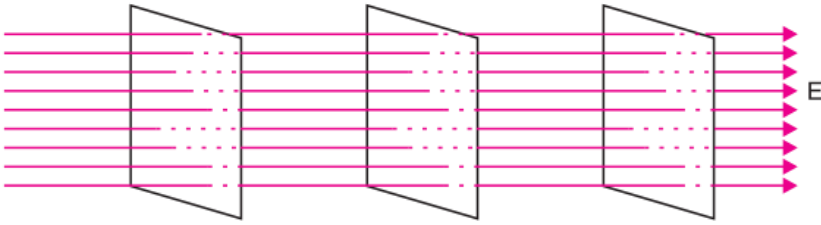

**Q. 8. A point charge Q is placed at point O as shown in the figure. The potential difference $V_A - V_B$ is positive. Is the charge Q negative or positive?
[CBSE (F) 2016]**



Ans.

We know that, $V = \frac{1}{4\pi\epsilon_0} \frac{Q}{r}$

$\Rightarrow V \propto \frac{1}{r}$

The potential due to a point charge decreases with increase of distance.

$V_A - V_B > 0 \quad \Rightarrow \quad V_A > V_B$

Hence, the charge Q is positive.

Q. 9. Depict the equipotential surfaces for a system of two identical positive point charges placed a distance 'd' apart. [CBSE Delhi 2010]

Ans. Equipotential surfaces due to two identical charges is shown in figure.

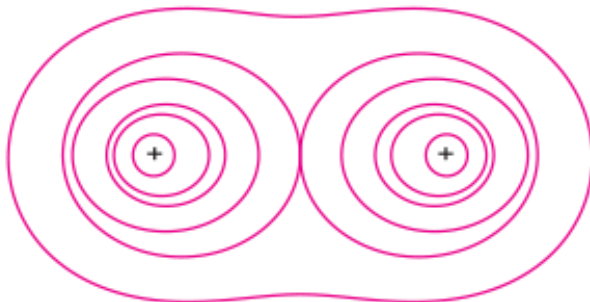

Q. 10. Draw an equipotential surface for a system consisting of two charges Q, -Q separated by a distance r in air. Locate the points where the potential due to the dipole is zero. [CBSE Delhi 2017, (AI) 2008, 2013]

Ans. The equipotential surface for the system is as shown. Electric potential is zero at all points in the plane passing through the dipole equator AB.

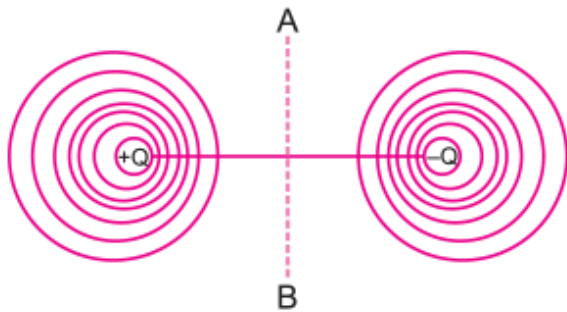

Q. 11. Why do the equipotential surfaces due to a uniform electric field not intersect each other? [CBSE (F) 2012]

Ans. This is because, at the point of intersection there will be two values of electric potential, which is not possible.

Q. 12. “For any charge configuration, equipotential surface through a point is normal to the electric field.” Justify. [CBSE Delhi 2014]

Ans. The work done in moving a charge from one point to another on an equipotential surface is zero. If electric field is not normal to the equipotential surface, it would have non-zero component along the surface. In that case work would be done in moving a charge on an equipotential surface.

Q. 13. Why is the potential inside a hollow spherical charged conductor constant and has the same value as on its surface? [CBSE (F) 2012]

Ans. Electric field intensity is zero inside the hollow spherical charged conductor. So, no work is done in moving a test charge inside the conductor and on its surface. Therefore, there is no potential difference between any two points inside or on the surface of the conductor.

$$V_A - V_B = - \int \vec{E} \cdot d\vec{l} = 0 \quad \Rightarrow V_A = V_B = \text{Constant}$$

Q. 14. A hollow metal sphere of radius 5 cm is charged such that the potential on its surface is 10 V. What is the potential at the centre of the sphere? [CBSE (AI) 2011]

Ans. Potential at centre of sphere = 10 V. Potential at all points inside the hollow metal sphere (or any surface) is always equal to the potential at its surface.

Q. 15. A charge ‘q’ is moved from a point A above a dipole of dipole moment ‘p’ to a point B below the dipole in equatorial plane without acceleration. Find the work done in the process. [CBSE Central 2016]

Ans. Work done in the process is zero. Because, equatorial plane of a dipole is equipotential surface and work done in moving charge on equipotential surface is zero.

$$W = qV_{AB} = q \times 0 = 0$$

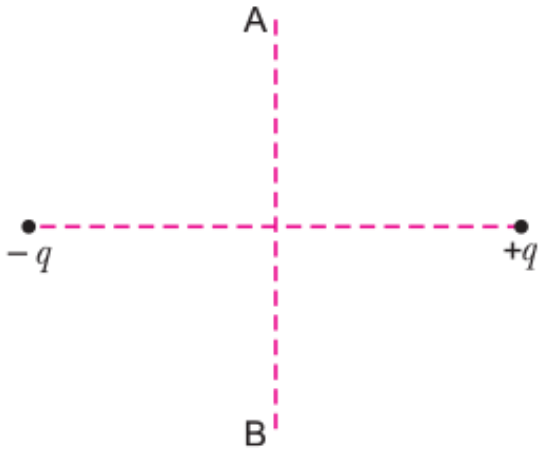

Q. 16. Why is there no work done in moving a charge from one point to another on an equipotential surface? [CBSE (F) 2012]

Ans. The potential difference between any two points of equipotential surface is zero. We have

$$V_1 - V_2 = \frac{W}{q} = 0 \quad \Rightarrow \quad W = 0$$

Therefore, the work done in moving a charge on an equipotential surface is zero.

Q. 17. What is the work done in moving a test charge q through a distance of 1 cm along the equatorial axis of an electric dipole? [CBSE (AI) 2009]

Ans. At every point on equatorial axis, the potential is zero, so work done

$$W = q \Delta V = 0 \text{ (zero).}$$

Q. 18. Figure shows the field lines due to a negative point charge. Give the sign of the potential energy difference of a small negative charge between the points A and B.

[CBSE (F) 2014]

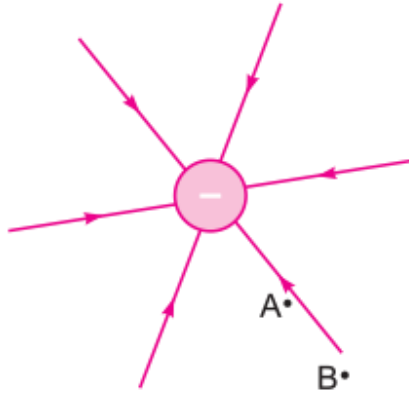

Ans.

$$U = \frac{1}{4\pi\epsilon_0} \cdot \frac{q_1 q_2}{r}$$

Since $r_A < r_B$

$$\therefore \frac{kq_1 q_2}{r_A} > \frac{kq_1 q_2}{r_B}$$

$$\therefore U_A > U_B$$

Therefore, $U_A - U_B$ is positive.

Q. 19. What is the amount of work done in moving a point charge Q around a circular arc of radius 'r' at the centre of which another point charge 'q' is located? [CBSE North 2016]

Ans. The potential of points A and B are same being equal to

$$V_A = V_B = \frac{1}{4\pi\epsilon_0} \frac{q}{R}$$

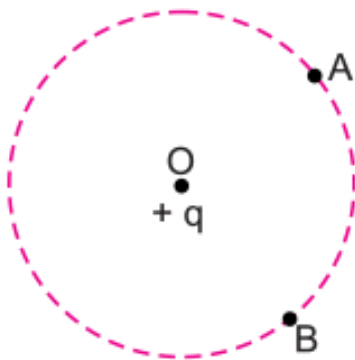

Where R is the radius of the circle.

Work done $W = q(V_B - V_A) = q(V_A - V_A) = 0$.

Q. 20. A metal plate is introduced between the plates of a charged parallel plate capacitor. What is its effect on the capacitance of the capacitor? [CBSE (F) 2009]

Ans. By introducing the metal plate between the plates of charged capacitor, the capacitance of capacitor increases

Reason: If t is thickness of metal plate, then

$$C = \frac{\epsilon_0 A}{d - t\left(1 - \frac{1}{K}\right)}$$

For metal plate $K = \infty$, $C = \frac{\epsilon_0 A}{(d - t)}$

Q. 21. The figure shows the field lines of a positive point charge. What will be the sign of the potential energy difference of a small negative charge between the points Q and P? Justify your answer. [CBSE Guwahati 2015]

Ans.

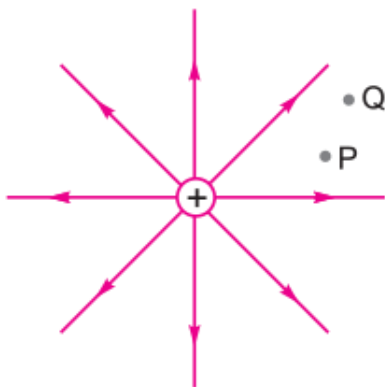

The sign of the potential energy difference of a small negative charge will be positive. This is because negative charge moves a point at a lower potential energy to a point at a higher potential energy.

Very Short Answer Questions (OIQ)

Q. 21. Show diagrammatically the arrangement of four point electric charges of

equal magnitude placed at four corners of a square such that the electric field as well as the electric potential at the centre of the square is non-zero.

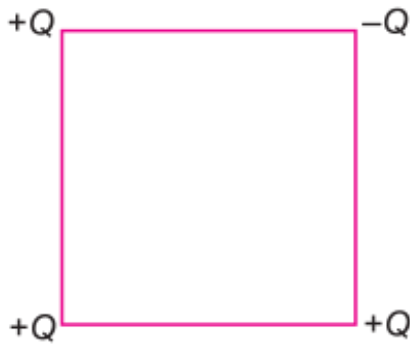

Ans. For the following arrangement of four point electric charges of equal magnitude, the electric field as well as electric potential at the centre of the square will be non-zero.

Q. 2. Can electric potential at a point be zero, while the electric field is not zero?

Ans. Yes, electric potential is zero at all points on equatorial line of electric dipole, while electric field strength is not zero.

Q. 3. Can electric field at a point be zero, while electric potential is not zero?

Ans. Yes, inside a hollow charged metallic conductor, the electric field is zero, but electric potential is finite.

Q. 4. Do free electrons travel to region of higher potential or lower potential?
[NCERT Exemplar]

Ans. Free electrons would travel to regions of higher potentials as they are negatively charged.

Q. 5. Can there be a potential difference between two adjacent conductors carrying the same charge? [NCERT Exemplar]

Ans. Yes.

Q. 6. Two protons are brought nearer; what will be the effect on potential energy of system?

Ans. A repulsive force acts between protons, if they are brought nearer, work must be done by external force; hence the potential energy of system increases.

Q. 7. An electron and a proton are brought nearer; how does the potential energy of system change?

Ans. There is attractive force between an electron and a proton, therefore when they come nearer, the work is done by the system itself and so the potential energy of system decreases.

Q. 8. Show that the equipotential surfaces are closed together in the regions of strong field and far apart in the regions of weak field. Draw equipotential surfaces for an electric dipole. [CBSE Sample Paper 2016]

Ans. Equipotential surfaces are closer together in the regions of strong field and farther apart in the regions of weak field.

$$E = -\frac{dV}{dr}$$

E = negative potential gradient

$$E = -\frac{dV}{dr}$$

For same change in dV,

where 'dr' represents the distance between equipotential surfaces.

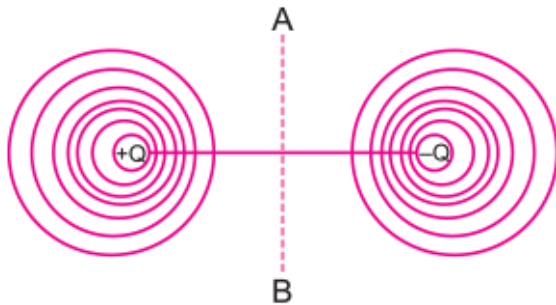

Q. 9. Concentric equipotential surfaces due to a charged body placed at the centre are shown. Identify the polarity of the charge and draw the electric field lines due to it.

[HOTS][CBSE Sample Paper 2016]

Ans.

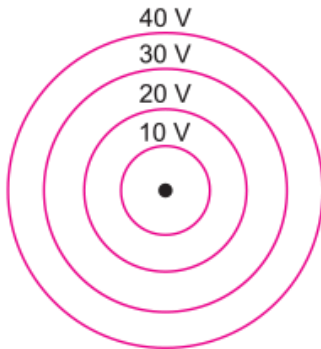

$$V = \frac{1}{4\pi\epsilon_0} \frac{q}{r}$$

For a single charge the potential is given by

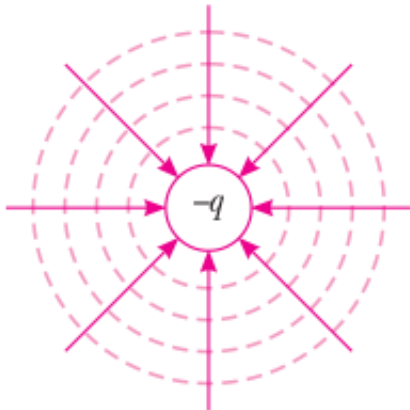

This shows that V is constant if r is constant. Greater the radius smaller will be the potential. In the given figure, potential is increasing. This shows that the polarity of charge is negative ($-q$). The direction of electric field will be radially inward. The field lines are directed from higher to lower potential.

Q. 10. A uniform electric field exists between two charged plates as shown in the fig. What should be the work done in moving a charge q along the closed rectangular path ABCDA? [HOTS]

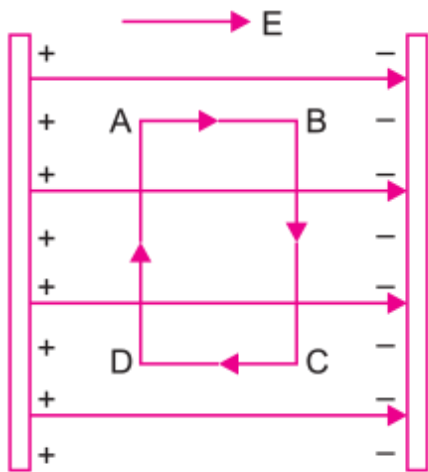

Ans. Work done in an electric field is independent of the path and depends only on the initial and final positions.

Here initial and final points are coincident.

$$\text{Work} = q \times (V_{\text{final}} - V_{\text{initial}})$$

$$= q (V_A - V_A)$$

So, net work done is zero.

Q. 11. The capacitance of a charged capacitor is C and the energy stored in it is U. What is the value of charge on the capacitor?

Ans.

Energy stored $U = \frac{Q^2}{2C}$ where Q is charge on capacitor.

$$\Rightarrow Q^2 = 2CU \quad \Rightarrow \text{Charge, } Q = \sqrt{2CU}$$

Q. 12. Sketch graph to show how charge Q given to a capacitor of capacitance C varies with the potential difference.

Ans. The graph of charge (Q) versus potential difference (V) is a straight line whose slope is equal to capacitance 'C'.

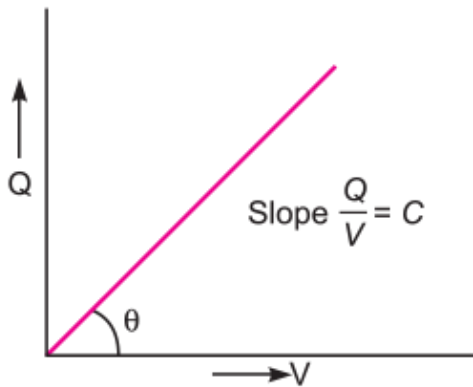

Q. 13. Name the dielectric whose molecules have

(i) Non-zero and

(ii) Zero dipole moment.

Ans. (i) The dielectric having non-zero dipole moment is water or HCl.

(ii) The dielectric having zero dipole moment is CH₄ or H₂.

Q. 14. Define dielectric constant of a medium. What is the value of dielectric constant for a metal?

Ans. The dielectric constant of a medium is defined on the ratio of permittivity of medium to the permittivity of free space. The dielectric constant is also called the relative permittivity of medium

$$\epsilon_r = K = \frac{\epsilon}{\epsilon_0}$$

The value of dielectric constant for a metal is infinity i.e., $K_{\text{metal}} = \infty$

Q. 15. Express dielectric constant of a medium in terms of capacitance. What is its SI unit?

Ans. The dielectric constant of a medium is defined as the ratio of capacitance of capacitor when filled with a medium to capacitance of same capacitor when medium is removed.

i.e.,
$$K = \frac{C_{\text{medium}}}{C_0}$$

It has no unit.

Q. 16. What is the function of a dielectric in a capacitor?

Ans. Dielectric reduces the effective potential on plates and hence increases the capacitance.

Q. 17. How does the electric field inside a dielectric decrease when it is placed in an external electric field?

Ans. When a dielectric is placed in an external electric field, the charges are induced on the faces of dielectric which produce opposite electric field in the dielectric. Thus net electric field inside the dielectric is reduced.

Q. 18. The graph shows the variation of voltage 'V' across the plates of two capacitors A and B versus increase of charge 'Q' stored on them. Which of the two capacitors has higher capacitance? Give reason for your answer.

[HOTS]

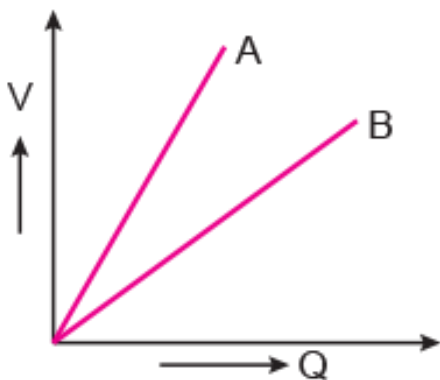

Ans.

$$C = \frac{Q}{V} = \frac{1}{\text{Slope of line}}$$

As slope of A is smaller, capacitance of A is higher.

Q. 19. The graph shown here shows the variation of total energy (E) stored in a capacitor against the value of the capacitance (C) itself. Which of the two: the charge on capacitor or the potential used to charge it, is kept constant for this graph?

[HOTS]

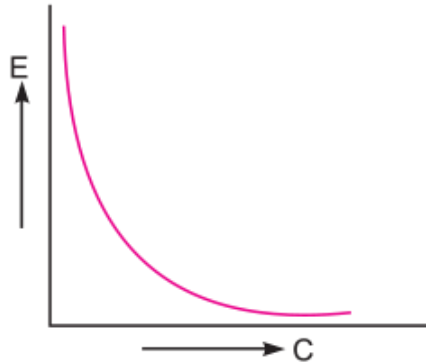

Ans. The given graph represents, $E \propto \frac{1}{C}$

This is satisfied by the expression, $E = \frac{q^2}{2C} \propto \frac{1}{C}$ for constant q.

That is, the charge (q) is kept constant.

Q. 20. If a point charge is rotated in an arc of radius r around a charge q, what will be the work done? Explain. [HOTS]

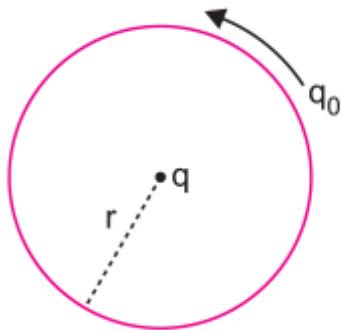

Ans. All points of circle of radius r are at same potential, hence work done is zero.

Q. 21. “Gauss’s law in electrostatics is true for any closed surface, no matter what its shape or size is.” Justify this statement with the help of a suitable example.

[HOTS]

Ans. According to Gauss theorem, the electric flux through a closed surface depends only on the net charge enclosed by the surface and not upon the shape or size of the surface.

For any closed arbitrary shape of the surface enclosing a charge the outward flux is the same as that due to a spherical Gaussian surface enclosing the same charge.

Justification: This is due to the fact that

(i) Electric field is radial and

$$E \propto \frac{1}{R^2}$$

(ii) The electric field

Short Answer Questions – I (PYQ)

Q. 1. Three points A, B and C lie in a uniform electric field (E) of $5 \times 10^3 \text{ NC}^{-1}$ as shown in the figure. Find the potential difference between A and C. [CBSE (F) 2009]

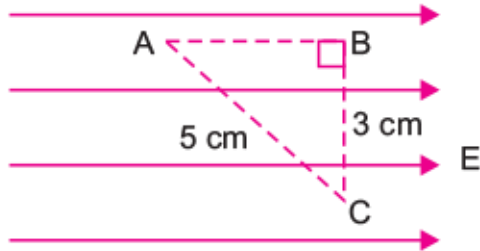

Ans. The line joining B to C is perpendicular to electric field, so potential of B = potential of C i.e., $V_B = V_C$

Distance AB = 4 cm

Potential difference between A and C = $E \times (AB)$

$$= 5 \times 10^3 \times (4 \times 10^{-2})$$

= 200 volt

Q. 2. Two uniformly large parallel thin plates having charge densities $+\sigma$ and $-\sigma$ are kept in the X-Z plane at a distance 'd' apart. Sketch an equipotential surface due to electric field between the plates. If a particle of mass m and charge ' $-q$ ' remains stationary between the plates, what is the magnitude and direction of this field?

[CBSE Delhi 2011]

Ans. The equipotential surface is at a distance $d/2$ from either plate in X-Z plane. For a particle of charge ($-q$) at rest between the plates, then

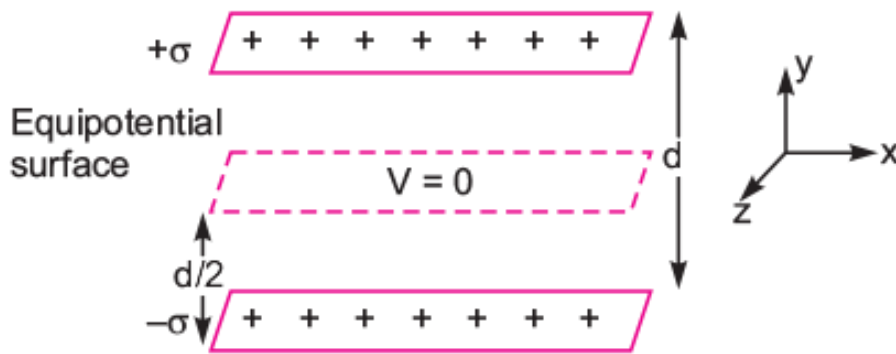

- (i) Weight mg acts vertically downward
- (ii) Electric force qE acts vertically upward.

so $mg = qE$

$$E = \frac{mg}{q}, \text{ Vertically downward, i.e., along } (-)Y\text{-axis.}$$

Q. 3. Plot a graph comparing the variation of potential 'V' and electric field 'E' due to a point charge 'Q' as a function of distance 'R' from the point charge. [CBSE Delhi 2012]

Ans. The graph of variation of potential and electric field due to a point charge Q with distance R from the point charge is shown in figure.

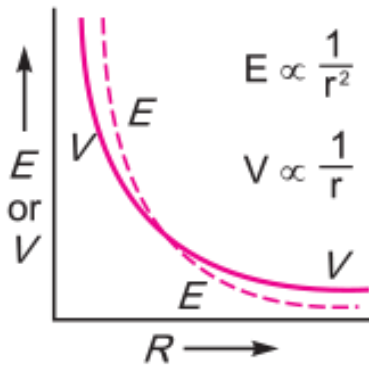

Q. 4. What is electrostatic shielding? How is this property used in actual practice? Is the potential in the cavity of a charged conductor zero? [CBSE South 2016]

Ans. Whatever be the charge and field configuration outside, any cavity in a conductor remains shielded from outside electric influence. The field inside a conductor is zero. This is known as electrostatic shielding.

Sensitive instruments are shielded from outside electrical influences by enclosing them in a hollow conductor.

During lightning it is safest to sit inside a car, rather than near a tree. The metallic body of a car becomes an electrostatic shielding from lightning.

Potential inside the cavity is not zero. Potential is constant.

Q. 5. Draw 3 equipotential surfaces corresponding to a field that uniformly increases in magnitude but remains constant along Z-direction. How are these surfaces different from that of a constant electric field along Z-direction? [CBSE (AI) 2009]

Ans. For constant electric field \vec{E} For increasing electric field

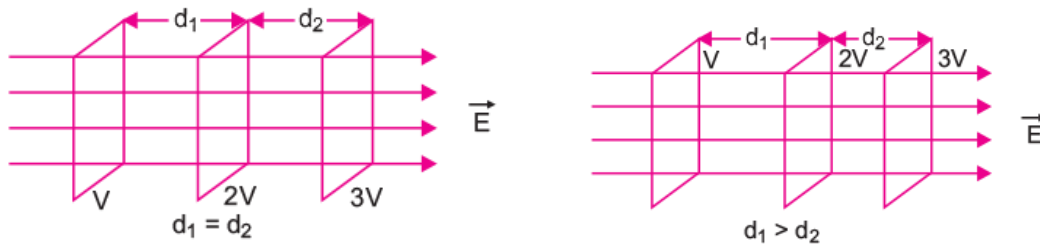

Difference: For constant electric field, the equipotential surfaces are equidistant for same potential difference between these surfaces; while for increasing electric field, the separation between these surfaces decreases, in the direction of increasing field, for the same potential difference between them.

Q. 6. Why does current in a steady state not flow in a capacitor connected across a battery? However momentary current does flow during charging or discharging of the capacitor. Explain. [CBSE (AI) 2017]

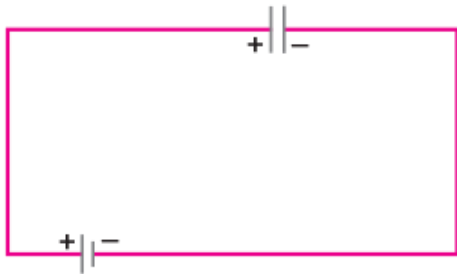

Ans. (i) In the steady state no current flows through capacitor because, we have two sources (battery and fully charged capacitor) of equal potential connected in opposition.

(ii) During charging or discharging there is a momentary flow of current as the potentials of the two sources are not equal to each other.

Q. 7. A test charge 'q' is moved without acceleration from A to C along the path from A to B and then from B to C in electric field E as shown in the figure.

(i) Calculate the potential difference between A and C.

(ii) At which point (of the two) is the electric potential more and why?

[CBSE (AI) 2012]

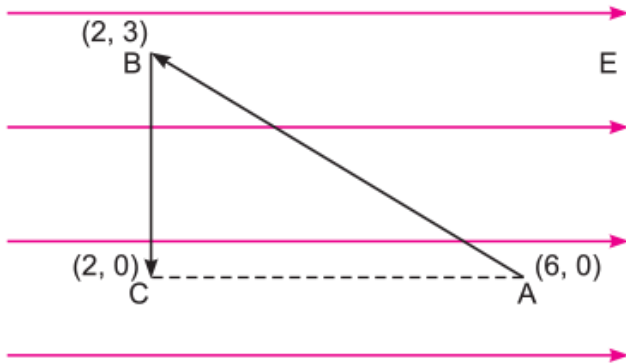

Ans. (i) Since electric field is conservative in nature, the amount of work done will depend upon initial and final positions only.

$$\therefore \text{Work done } W = \vec{F} \cdot \vec{d} = q \vec{E} \cdot \vec{d} = qE \cdot 4 \cos 180^\circ$$

$$= -4 qE$$

Hence $V_C - V_A = \frac{W}{q} = -4E$

(ii) $V_C > V_A$, because direction of electric field is in decreasing potential.

Q. 8. Figure shows a sheet of aluminium foil of negligible thickness placed between the plates of a capacitor. How will its capacitance be affected if:
[CBSE (F) 2009]

- (i)** The foil is electrically insulated?
- (ii)** The foil is connected to the upper plate with a conducting wire?

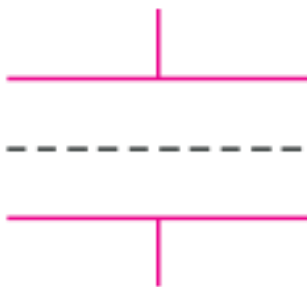

Ans. (i) No effect on capacitance if foil is electrically neutral.

(ii) If foil is connected to upper plate with a conducting wire, the effective separation between plates becomes half, so capacitance is doubled.

Q. 9. Find the charge on the capacitor as shown in the circuit. [CBSE (F) 2014]

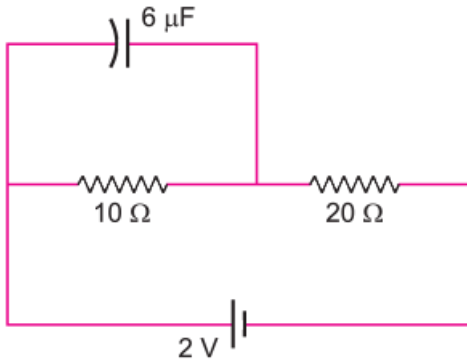

Ans.

Total resistance, $R = 10\Omega + 20\Omega = 30\Omega$

$$\text{The current, } I = \frac{V}{R} = \frac{2V}{30\Omega} = \frac{1}{15} A$$

$$\text{Potential difference, } V = IR = \frac{1}{15} \times 10 = \frac{2}{3} V$$

$$\text{Charge, } q = CV = 6 \times \frac{2}{3} = 4\mu C$$

Q. 10. Figure shows two identical capacitors, C_1 and C_2 , each of $1 \mu F$ capacitance connected to a battery of $6 V$. Initially switch 'S' is closed. After sometimes 'S' is left open and dielectric slabs of dielectric constant $K = 3$ are inserted to fill completely the space between the plates of the two capacitors. How will the (i) charge and (ii) potential difference between the plates of the capacitors be affected after the slabs are inserted? [CBSE Delhi 2011]

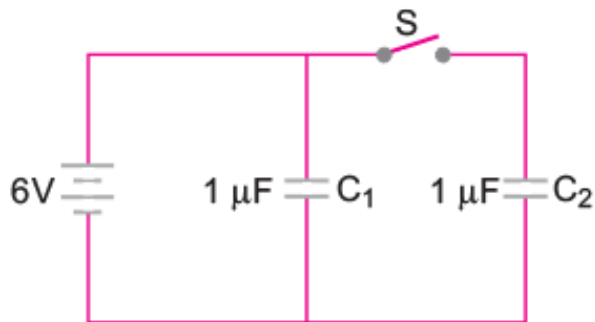

Ans. When switch S is closed, p.d. across each capacitor is $6V$

$$V_1 = V_2 = 6 V$$

$$C_1 = C_2 = 1 \mu C$$

∴ Charge on each capacitor

$$q_1 = q_2 (= CV) = (1 \mu\text{F}) \times (6 \text{ V}) = 6 \mu\text{C}$$

When switch S is opened, the p.d. across C_1 remains 6 V, while the charge on capacitor C_2 remains 6 μC . After insertion of dielectric between the plates of each capacitor, the new capacitance of each capacitor becomes

$$C'_1 = C'_2 = 3 \times 1 \mu\text{F} = 3 \mu\text{F}$$

Charge on capacitor C_1 , $q'_1 = C'_1 V_1 = (3 \mu\text{F}) \times 6 \text{ V} = 18 \mu\text{C}$ Charge on capacitor C_2 remains 6 μC

Potential difference across C_1 remains 6 V. Potential difference across C_2 becomes

$$V'_2 = \frac{q_2}{C'_2} = \frac{6 \mu\text{C}}{3 \mu\text{F}} = 2 \text{ V}$$

Q. 11. Answer the following questions

(i) A parallel plate capacitor (C_1) having charge Q is connected, to an identical uncharged capacitor C_2 in series. What would be the charge accumulated on the capacitor C_2 ? [CBSE South 2016]

(ii) Three identical capacitors each of capacitance 3 μF are connected, in turn, in series and in parallel combination to the common source of V volt. Find out the ratio of the energies stored in two configurations. [CBSE South 2016]

Ans. (i) Zero

(ii)

$$\text{We have } C_{\text{series}} = \frac{3 \mu\text{F}}{3} = 1 \mu\text{F}$$

$$\text{Also, } C_{\text{parallel}} = (3 + 3 + 3) = 9 \mu\text{F}$$

$$\text{Energy stored} = \frac{1}{2} CV^2$$

$$\therefore \text{Energy in series combination} = \frac{1}{2} \times 1 \times 10^{-6} \times V^2 \Rightarrow U_{\text{series}} = \frac{10^{-6}}{2} V^2$$

$$\therefore \text{Energy in parallel combination} = \frac{1}{2} \times 9 \times 10^{-6} \times V^2 \Rightarrow U_{\text{parallel}} = \frac{10^{-6} \times 9}{2} V^2$$

$$\therefore U_{\text{series}} : U_{\text{parallel}} = 1 : 9$$

Q. 12. Net capacitance of three identical capacitors in series is $1 \mu\text{F}$. What will be their net capacitance if connected in parallel?

Find the ratio of energy stored in the two configurations if they are both connected to the same source. [CBSE (AI) 2011]

Ans. Let C be the capacitance of each capacitor, then in series

$$\frac{1}{C_s} = \frac{1}{C} + \frac{1}{C} + \frac{1}{C} = \frac{3}{C}$$

Or $C = 3C_s = 3 \times 1 \mu\text{F} = 3 \mu\text{F}$

When these capacitors are connected in parallel, net capacitance, $C_p = 3C = 3 \times 3 = 9 \mu\text{F}$

When these two combinations are connected to same source the potential difference across each combination is same.

Ratio of energy stored,

$$\frac{U_s}{U_p} = \frac{\frac{1}{2} C_s V^2}{\frac{1}{2} C_p V^2} = \frac{C_s}{C_p} = \frac{1 \mu\text{F}}{9 \mu\text{F}} = \frac{1}{9}$$

$$U_s : U_p = 1 : 9$$

Q. 13. Find the equivalent capacitance of the network shown in the figure, when each capacitor is of $1 \mu\text{F}$. When the ends X and Y are connected to a 6 V battery, find out

(i) The charge and

(ii) The energy stored in the network. [CBSE Patna 2015]

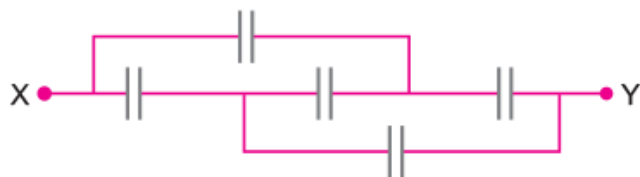

Ans. The given circuit can be rearranged as

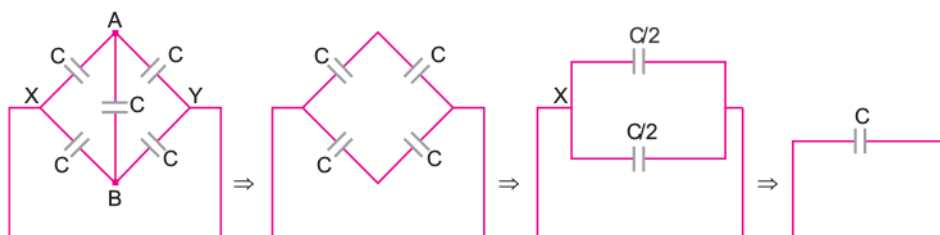

It is known as wheat stone bridge of the capacitor. Since $V_A = V_B$, so the bridge capacitor between points A and B can be removed.

(i) The equivalent capacitor of the network

$$C_{eq} = \frac{C \times C}{C+C} + \frac{C \times C}{C+C}$$

$$= \frac{C}{2} + \frac{C}{2}$$

$$= C = 1\mu F$$

Charge in the network, $Q = C_{eq} V$

$$= C \times V = 1 \mu F \times 6 V = 6 \mu C$$

(ii) Energy stored in the capacitor,

$$U = \frac{1}{2} C_{eq} V^2$$

$$= \frac{1}{2} \times 1 \mu F \times (6)^2$$

$$= 18 \mu J$$

Q. 14. A network of four capacitors each of $15 \mu F$ capacitance is connected to a $500 V$ supply as shown in the figure. Determine

- (a) Equivalent capacitance of the network and
 (b) Charge on each capacitor. [CBSE (AI) 2010]

Ans. (a) C_1, C_2 and C_3 are in series, their equivalent capacitance C' is given by

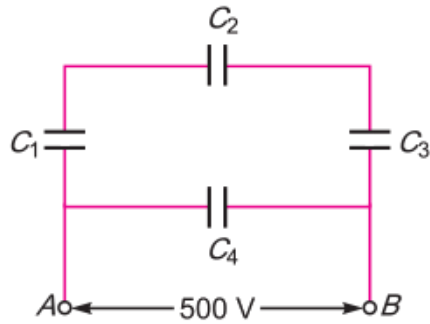

$$\frac{1}{C'} = \frac{1}{C_1} + \frac{1}{C_2} + \frac{1}{C_3} = \frac{1}{15} + \frac{1}{15} + \frac{1}{15}$$

$$\Rightarrow C' = 5 \mu\text{F}$$

C_4 is in parallel with C , so equivalent capacitance of network

$$C_{eq} = C + C_4 = 5 + 15 = 20 \mu\text{F}$$

b. Charge on capacitor C_4 is

$$q_4 = C_4 V = (15 \mu\text{F}) \times 500 \text{ V} = 7500 \mu\text{C} = 7.5 \text{ mC}$$

Charge on C_1 , C_2 and C_3 is

$$\begin{aligned} q_1 = q_2 = q_3 &= C V \\ &= 5 \mu\text{F} \times 500 \text{ V} = 2500 \mu\text{C} = 2.5 \text{ mC} \end{aligned}$$

Q. 15. Four charges $+q$, $-q$, $+q$ and $-q$ are to be arranged respectively at the four corners of a square ABCD of side 'a'.

(i) Find the work required to put together this arrangement. [Hots][CBSE (F) 2015]

(ii) A charge q_0 is brought to the centre of the square, the four charges being held fixed. How much extra work is needed to do this? [Hots][CBSE (F) 2015]

Ans. (i) Work done in bringing charge $+q$ at point A

$$W_A = 0$$

Work done in bringing charge $-q$ to the point B

$$W_B = W_{AB} = -q \times \frac{1}{4\pi\epsilon_0} \frac{q}{a} = -\frac{1}{4\pi\epsilon_0} \frac{q^2}{a}$$

Work done in bring the charge +q to the point C

$$W_C = W_{AC} + W_{BC}$$

$$= q \times \frac{1}{4\pi\epsilon_0} \cdot \frac{q}{a\sqrt{2}} + q \times \left(-\frac{1}{4\pi\epsilon_0} \frac{q}{a} \right) = \frac{1}{4\pi\epsilon_0} \cdot \frac{q^2}{a\sqrt{2}} - \frac{1}{4\pi\epsilon_0} \cdot \frac{q^2}{a}$$

Work done in bringing a charge – q to the point D

$$W_D = W_{AD} + W_{BD} + W_{CD}$$

$$= -q \times \frac{1}{4\pi\epsilon_0} \frac{q}{a} + (-q) \left(\frac{1}{4\pi\epsilon_0} \frac{-q}{a\sqrt{2}} \right) + (-q) \times \frac{1}{4\pi\epsilon_0} \cdot \frac{q}{a}$$

Total work done $W = W_A + W_B + W_C + W_D$

$$= 2 \times \frac{1}{4\pi\epsilon_0} \frac{q^2}{a\sqrt{2}} - 4 \times \frac{1}{4\pi\epsilon_0} \frac{q^2}{a} = \frac{1}{4\pi\epsilon_0} \frac{q^2}{a} (\sqrt{2} - 4)$$

Short Answer Questions – I (OIQ)

Q. 1. Establish the relation between electric field and potential gradient.

Ans. Let us consider two closely spaced equipotential surfaces A and B as shown in figure.

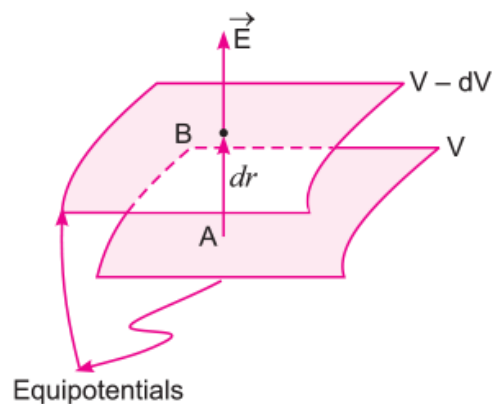

Let the potential of A be $V_A = V$ and potential of B be $V_B = V - dV$ where dV is decrease in potential in the direction of electric field \vec{E} normal to A and B.

Let dr be the perpendicular distance between the two equipotential surfaces. When a unit positive charge is moved along this perpendicular from the surface B to surface A against the electric field, the work done in this process is

$$W_{BA} = -\vec{E} \cdot (dr)$$

This work done equals the potential difference $V_A - V_B$.

$$\therefore W_{BA} = V_A - V_B = V - (V - dV) = dV$$

$$\therefore -\vec{E} \cdot dr = dV$$

$$\text{or, } \vec{E} = -\frac{dV}{dr} = \text{negative of potential gradient}$$

Q. 2. How does the energy stored in a capacitor change if after disconnecting the battery, the plates of a charged capacitor are moved farther?

Ans. Capacitance $C \propto \frac{1}{d}$, when plates of a capacitor are moved farther, the capacitance decreases. After disconnecting the battery, the charge on capacitor remains constant, therefore the energy stored by capacitor $U \left(= \frac{q^2}{2C} \right)$, increases.

Q. 3. How does the energy stored in a capacitor change if the plates of a charged capacitor are moved farther, the battery remaining connected?

Ans. The capacitance of capacitor decreases on moving its plates farther. As the battery remains connected, the potential difference remains constant. Hence, energy stored $U = \frac{1}{2}CV^2$, decreases.

Q. 4. When a capacitor is charged by a battery; is the energy stored in the capacitor same as energy supplied by the battery?

Ans. No, Energy stored in the capacitor $= \frac{1}{2}CV^2 = \frac{1}{2}qV$ while energy supplied by battery $= qV$.

The balance of energy is dissipated as heat during charging.

Q. 5. The given graph shows the variation of charge q versus potential difference V for two capacitors C_1 and C_2 . The two capacitors have same plate separation but the plate area of C_2 is double than that of C_1 . Which of the two graphs P and Q correspond to capacitors C_1 and C_2 and why?

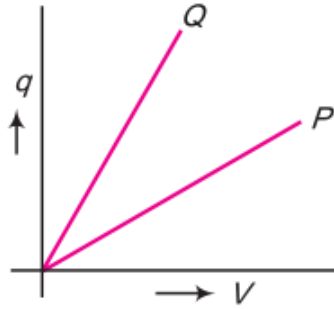

Ans. Q represents C_2 and P represents C_1

Reason: From the graph the slope $q/v = \text{Capacitance}$ is greater for Q.

Also according to given conditions the capacitance $\frac{\epsilon A}{d}$ is larger for the C_2 because the area of its plates is large and d for the two capacitors is same. Hence, Q represents C_2 .

Q. 6. Find the total energy stored in the capacitors in the given network.

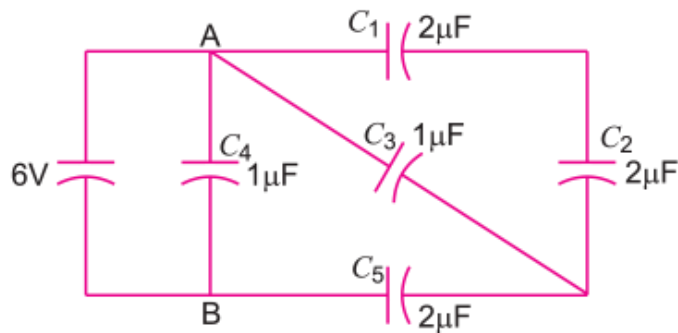

Ans. The equivalent capacitance of C_1 and C_2 in series

$$C' = \frac{C_1 C_2}{C_1 + C_2} = \frac{2 \times 2}{2 + 2} = 1 \mu F$$

C' is in parallel with C_3 , so equivalent capacitance of C_1 , C_2 and C_3 is

$$C'' = 1 + 1 = 2 \mu F$$

C'' is in series with C_4 ; their equivalent capacitance

$$C''' = \frac{C_4 C''}{C_4 + C''} = \frac{2 \times 2}{2 + 2} = 1 \mu F$$

This is in parallel with C_5 ; So equivalent capacitance across AB is $C_{AB} = 1 + 1 = 2 \mu F$

$$\text{Energy stored } V = \frac{1}{2} C_{AB} V^2 = \frac{1}{2} \times 2 \times 10^{-6} \times (6)^2 = 36 \times 10^{-6} J$$

Q. 7. Three point charges +Q, -2Q and -3Q are placed at the vertices of an equilateral triangle ABC of side l

If these charges are displaced to the mid points A₁, B₁ and C₁ respectively, calculate the amount of work done in shifting the charges to the new locations. [HOTS]

Ans. Work done to put the three charges at A, B and C

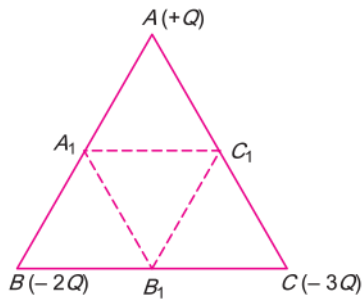

$$U_{\text{initial}} = \frac{1}{4\pi\epsilon_0} \left[\frac{Q(-2Q)}{l} + \frac{Q(-3Q)}{l} + \frac{2Q(3Q)}{l} \right]$$

$$= \frac{1}{4\pi\epsilon_0} \frac{1Q^2}{l}.$$

Work done to take the three charges to position A₁, B₁ and C₁

$$U_{\text{initial}} = \frac{1}{4\pi\epsilon_0} \left[\frac{Q(-2Q)}{l/2} + \frac{Q(-3Q)}{l/2} + \frac{2Q(3Q)}{l/2} \right]$$

$$= \frac{1}{4\pi\epsilon_0} \frac{2Q^2}{l}.$$

Work done to shift the charges to the new locations is

$$W = U_{\text{final}} - U_{\text{initial}} = - \frac{1}{4\pi\epsilon_0} \frac{2Q^2}{l}$$

Q. 8. Consider two conducting spheres of radii R₁ and R₂ with R₁ > R₂. If the two are at the same potential, the larger sphere has more charge than the smaller sphere. State whether the charge density of the smaller sphere is more or less than that of the larger one. [HOTS][NCERT Exemplar]

Ans. Since two spheres are at the same potential, therefore

$$V_1 = V_2$$

$$\frac{Q_1}{4\pi\epsilon_0 R_1} = \frac{Q_2}{4\pi\epsilon_0 R_2}$$

$$\Rightarrow \frac{Q_1}{Q_2} = \frac{R_1}{R_2}$$

$$\text{Given, } R_1 > R_2, \quad \therefore \quad Q_1 > Q_2$$

\Rightarrow Larger sphere has more charge

$$\text{Now,} \quad \sigma_1 = \frac{Q_1}{4\pi R_1^2} \quad \text{and} \quad \sigma_2 = \frac{Q_2}{4\pi R_2^2}$$

$$\frac{\sigma_2}{\sigma_1} = \frac{Q_2}{Q_1} \cdot \frac{R_1^2}{R_2^2}$$

$$\Rightarrow \frac{\sigma_2}{\sigma_1} = \frac{R_2}{R_1} \cdot \frac{R_1^2}{R_2^2} \quad [\text{From equation (i)}]$$

Since $R_1 > R_2$, therefore $\sigma_2 > \sigma_1$.

Charge density of smaller sphere is more than that of larger one.

Q. 9. The two graphs are drawn below, show the variations of electrostatic potential (V) $1/r$ (r being the distance of field point from the point charge) for two point charges q_1 and q_2 .

(i) What are the signs of the two charges?

(ii) Which of the two charges has the larger magnitude and why? [HOTS]

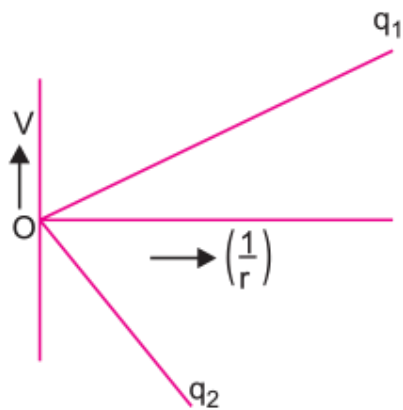

Ans. (i) The potential due to positive charge is positive and due to negative charge, it is negative, so, q_1 is positive and q_2 is negative.

(ii)
$$V = \frac{1}{4\pi\epsilon_0} \frac{q}{r}$$

The graph between V and $1/r$ is a straight line passing through the origin with slope $\frac{q}{4\pi\epsilon_0}$

As the magnitude of slope of the line due to charge q_2 is greater than that due to q_1 , q_2 has larger magnitude.

Q. 10. The potential V due to a charge distribution at a point (x, y) is given by $V = -x^2 + 3y$

Calculate the electric field, in magnitude and direction, due to this charge configuration at the point $(1, 1)$. [HOTS]

Ans.

$$V = -4x^2 + 3y$$

$$\therefore E_x = -\frac{\partial V}{\partial x} = +8x \quad \text{and} \quad E_y = -\frac{\partial V}{\partial y} = -3$$

$$\therefore \text{Total } \vec{E} = 8x\hat{i} - 3\hat{j}$$

$$\text{At point } (1, 1), \vec{E} = 8x\hat{i} - 3\hat{j}$$

$$\therefore |\vec{E}| = \sqrt{(8)^2 + (3)^2} = \sqrt{73} \text{ N/C}$$

Also angle θ , which \vec{E} makes with x-axis, is given by

$$\tan \theta = \frac{E_y}{E_x} = -\frac{3}{8} = -0.375$$

$$\theta = \tan^{-1}(-0.375)$$

Q. 11. Two charges 5 nC and -2 nC are placed at points (5 cm, 0, 0) and (23 cm, 0, 0) in a region of space where there is no other external field. Calculate the electrostatic potential energy of this charge system. [HOTS]

Ans. Given $q_1 = 5 \text{ nC} = 5 \times 10^{-9} \text{ C}$, $q_2 = -2 \text{ nC} = -2 \times 10^{-9} \text{ C}$

The charges are placed on X-axis. The distance between the charges

$$x = x_2 - x_1 = (23 - 5) \text{ cm} = 18 \text{ cm} = 0.18 \text{ m}$$

\therefore Electrostatic potential energy of charges

$$U = \frac{1}{4\pi\epsilon_0} \frac{q_1 q_2}{x}$$

$$\frac{9 \times 10^9 (5 \times 10^{-9})(-2 \times 10^{-9})}{0.18} = 5 \times 10^{-7} \text{ J}$$

Q. 12. A very thin plate of metal is placed exactly in the middle of the two plates of a parallel plate capacitor. What will be the effect on the capacitance of the system?

[HOTS]

Ans. For a metal $K=\infty$ and so when $t \ll d$, the capacitance

$$C = \frac{\epsilon_0 A}{d-t\left(1-\frac{1}{K}\right)} = \frac{\epsilon_0 A}{d-t\left(1-\frac{1}{\infty}\right)} = \frac{\epsilon_0 A}{d-t}$$

As $t \ll d$ $C = \frac{\epsilon_0 A}{d}$, i.e., capacitance will remain unchanged.

Short Answer Questions – II (PYQ)

Q. 1. Define an equipotential surface. Draw equipotential surfaces:

(i) In the case of a single point charge and

(ii) In a constant electric field in Z-direction.

Why the equipotential surfaces about a single charge are not equidistant?

(iii) Can electric field exist tangential to an equipotential surface? Give reason.

[CBSE Central 2016]

Ans. An equipotential surface is the surface with a constant value of potential at all points on the surface. Equipotential surface:

(i) In case of a single point charge

Here point charge is positive, if it is negative then electric field will be radially inward but equipotential surfaces are same and are concentric spheres with centres at the charge.

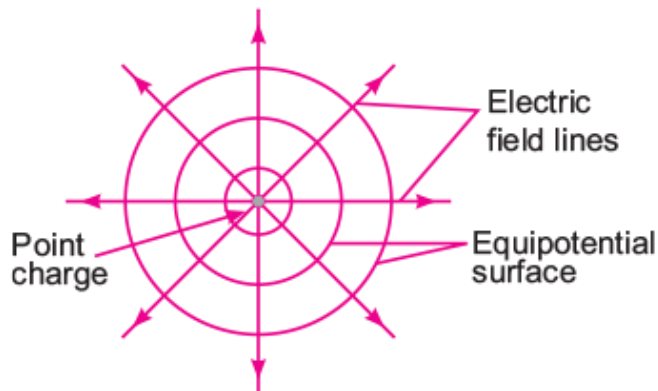

(ii) In case of electric field in Z-direction

Potential of a point charge at a distance $r = \frac{1}{4\pi\epsilon_0} \frac{q}{r}$

$$\therefore V \propto \frac{1}{r}$$

Hence equipotential surfaces about a single charge are not equidistant.

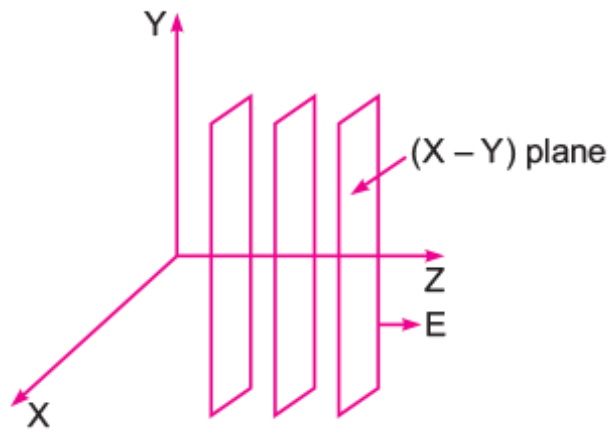

(iii) No if the field lines are tangential, work will be done in moving a charge on the surface which goes against the definition of equipotential surface.

Q. 2. Show that the potential energy of a dipole making angle θ with the direction of the field is given by $U(\theta) = - \vec{p} \cdot \vec{E}$. Hence find out the amount of work done in rotating it from the position of unstable equilibrium to the stable equilibrium.
[CBSE East 2016]

Ans. The potential energy of an electric dipole in an electric field is defined as the work done in bringing the dipole from infinity to its present position in the electric field.

Suppose the dipole is brought from infinity and placed at orientation θ with the direction of electric field. The work done in this process may be supposed to be done in two parts.

(i) The work done (W_1) in bringing the dipole perpendicular to electric field from infinity.

(ii) Work done (W_2) in rotating the dipole such that it finally makes an angle θ from the direction of electric field.

Let us suppose that the electric dipole is brought from infinity in the region of a uniform electric field such that its dipole moment \vec{p} always remains perpendicular to electric field. The electric forces on charges $+q$ and $-q$ are qE and qE , along the field direction and opposite to field direction respectively.

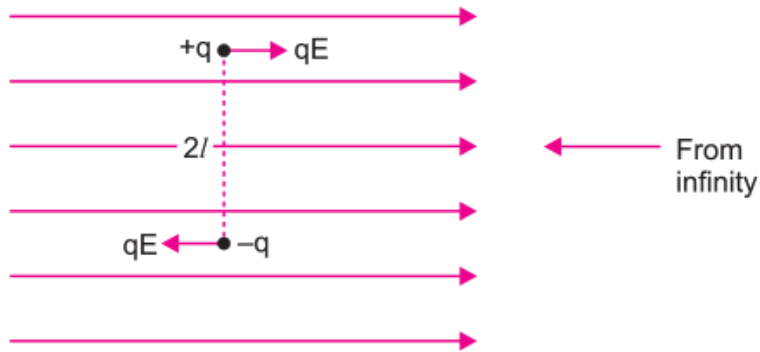

As charges $+q$ and $-q$ traverse equal distance under equal and opposite forces; therefore, net work done in bringing the dipole in the region of electric field perpendicular to field-direction will be zero, i.e., $W_1 = 0$.

Now the dipole is rotated and brought to orientation making an angle θ with the field direction (i.e., $\theta_0 = 90^\circ$ and $\theta_1 = \theta^\circ$), therefore, work done

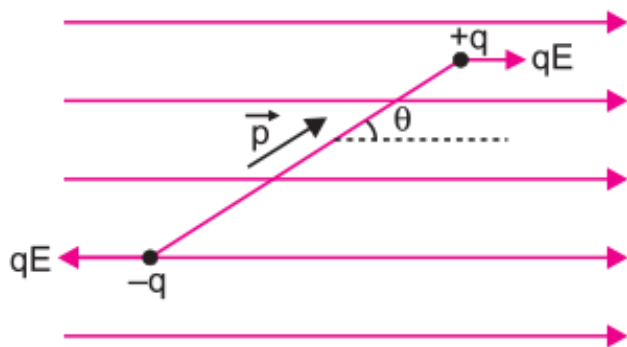

$$W_2 = pE (\cos \theta^\circ - \cos \theta_1)$$

$$= pE (\cos 90^\circ - \cos \theta) = - pE \cos \theta$$

∴ Total work done in bringing the electric dipole from infinity, i.e.,

Electric potential energy of electric dipole

$$U = W_1 + W_2 = 0 - pE \cos \theta^\circ = - pE \cos \theta$$

In vector form $U = - \vec{p} \cdot \vec{E}$

For rotating dipole from position of unstable equilibrium ($\theta_0 = 180^\circ$) to the stable equilibrium ($\theta = 0^\circ$)

$$\therefore W_{\text{req}} = pE (\cos 180^\circ - \cos 0^\circ)$$

$$pE(-1 - 1) = - 2pE$$

Q. 3. Three concentric metallic shells A, B and C of radii a, b and c ($a < b < c$) have surface charge densities $+\sigma$, $-\sigma$ and $+\sigma$ respectively as shown in the figure.

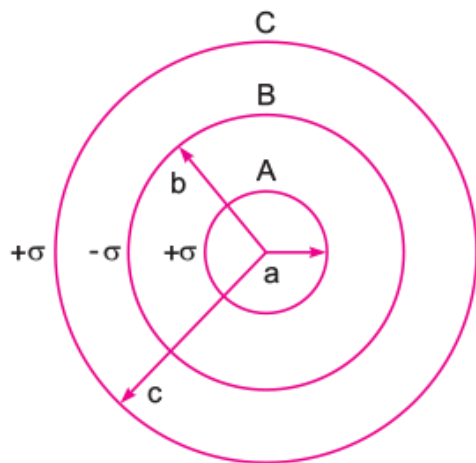

If shells A and C are at the same potential, then obtain the relation between the radii a, b and c. [CBSE (F) 2014]

Ans.

Charge on shell A , $q_A = 4\pi a^2 \sigma$

Charge on shell B , $q_B = -4\pi b^2 \sigma$

Charge of shell C , $q_C = 4\pi c^2 \sigma$

Potential of shell A : Any point on the shell A lies inside the shells B and C .

$$\begin{aligned} V_A &= \frac{1}{4\pi\epsilon_0} \left[\frac{q_A}{a} + \frac{q_B}{b} + \frac{q_C}{c} \right] \\ &= \frac{1}{4\pi\epsilon_0} \left[\frac{4\pi a^2 \sigma}{a} - \frac{4\pi b^2 \sigma}{b} + \frac{4\pi c^2 \sigma}{c} \right] \\ &= \frac{\sigma}{\epsilon_0} (a - b + c) \end{aligned}$$

Any point on B lies outside the shell A and inside the shell C . Potential of shell B ,

$$\begin{aligned} V_B &= \frac{1}{4\pi\epsilon_0} \left[\frac{q_A}{b} + \frac{q_B}{b} + \frac{q_C}{c} \right] \\ &= \frac{1}{4\pi\epsilon_0} \left[\frac{4\pi a^2 \sigma}{b} - \frac{4\pi b^2 \sigma}{b} + \frac{4\pi c^2 \sigma}{c} \right] = \frac{\sigma}{\epsilon_0} \left[\frac{a^2}{b} - b + c \right] \end{aligned}$$

Any point on shell C lies outside the shells A and B . Therefore, potential of shell C .

$$\begin{aligned}V_C &= \frac{1}{4\pi\epsilon_0} \left[\frac{q_A}{c} + \frac{q_B}{b} + \frac{q_C}{c} \right] \\&= \frac{1}{4\pi\epsilon_0} \left[\frac{4\pi a^2 \sigma}{c} - \frac{4\pi b^2 \sigma}{c} + \frac{4\pi c^2 \sigma}{c} \right] \\&= \frac{\sigma}{\epsilon_0} \left[\frac{a^2}{c} - \frac{b^2}{c} + c \right]\end{aligned}$$

Now, we have

$$V_A = V_C$$

$$\frac{\sigma}{\epsilon_0} (a - b + c) = \frac{\sigma}{\epsilon_0} \left(\frac{a^2}{c} - \frac{b^2}{c} + c \right)$$

$$a - b = \frac{(a - b)(a + b)}{c}$$

$$\text{or } a + b = c$$

Q. 4. A parallel plate capacitor each with plate area A and separation ' d ' is charged to a potential difference V . The battery used to charge it is then disconnected. A dielectric slab of thickness d and dielectric constant K is now placed between the plates. What change if any, will take place in [CBSE (F) 2010]

- (i) Charge on the plates
- (ii) Electric field intensity between the plates,
- (iii) Capacitance of the capacitor

Justify your answer in each case.

Ans.

Initial capacitance $C_0 = \frac{\epsilon_0 A}{d}$, Potential difference = V

i. Initial charge, $q_0 = C_0 V = \frac{\epsilon_0 A}{d} V$

∴ When battery is disconnected the charge on the capacitor remains unchanged and equal to

$$q = q_0 = \frac{\epsilon_0 A}{d} V.$$

ii. Initial electric field between the plates, $E_0 = \frac{\sigma}{\epsilon_0} = \frac{q/A}{\epsilon_0} = \frac{q}{A \epsilon_0}$

After introduction of dielectric; the permittivity of medium becomes $K\epsilon_0$;

so final electric field between the plates, $E = \frac{q}{AK \epsilon_0} = \frac{E_0}{K}$ i.e., electric field reduces to $\frac{1}{K}$ times.

(iii) After introduction of dielectric, the capacitance becomes KC_0 .

Q. 5. A parallel plate capacitor is charged by a battery, which is then disconnected. A dielectric slab is then inserted in the space between the plates. Explain what changes, if any, occur in the values of: [CBSE Delhi 2010, (AI) 2009, 2012]

(i) Capacitance

(ii) Potential difference between the plates

(iii) Electric field between the plates, and

(iv) The energy stored in the capacitor.

Ans. (i) The capacitance of capacitor increases to K times (since $C = \frac{K\epsilon_0 A}{d} \propto K$)

(ii) The potential difference between the plates becomes $1/K$ times.

Reason: $V = \frac{Q}{C}$; Q same, C increases to K times; $V' = \frac{V}{K}$

(iii) As $E = \frac{V}{d}$ and V is decreased; therefore, electric field decreases to $\frac{1}{K}$ times.

(iv)

Energy stored will be decreased. The energy becomes, $U = \frac{Q_0^2}{2} = \frac{Q_0^2}{2K_0} = \frac{U_0}{K}$

Thus, energy is reduced to $\frac{1}{K}$ times the initial energy.

Q. 6. A parallel plate is charged by a battery. When the battery remains connected, a dielectric slab is inserted in the space between the plates. Explain what changes if any, occur in the values of [CBSE Delhi 2010]

(i) Potential difference between the plates

(ii) Capacitance

(iii) Charge on the plates

(iv) Energy stored in the capacitor?

(v) Electric field strength between the plates

Ans. (i) When battery remains connected, the potential difference remains the same.

(ii) The capacitance of capacitor increases as $K > 1$.

(iii) The charge $Q = CV$, $V =$ same, $C =$ increases; there, charge on plates increases.

Energy stored by capacitor $U = \frac{1}{2}CV^2$, also increases.

(iv)

(v) As electric field $E = \frac{V}{d}$, $V =$ constant and $d =$ constant; therefore, electric field strength remains the same.

Q. 7. Answer the following questions

(i) Find equivalent capacitance between A and B in the combination given below. Each capacitor is of $2\mu\text{F}$ capacitance. [CBSE Delhi 2017]



(ii) If a dc source of 7V is connected across AB, how much charge is drawn from the source and what is the energy stored in the network? [CBSE Delhi 2017]

Ans.

Capacitors C_2 , C_3 and C_4 are in parallel

$$C_{234} = C_2 + C_3 + C_4 = 2\mu\text{F} + 2\mu\text{F} + 2\mu\text{F}$$

$$\therefore C_{234} = 6\mu\text{F}$$

Capacitors C_1 , C_{234} and C_5 are in series,

$$\frac{1}{C_{\text{eq}}} = \frac{1}{C_1} + \frac{1}{C_{234}} + \frac{1}{C_5} = \frac{1}{2} + \frac{1}{6} + \frac{1}{2}$$

$$= \frac{7}{6}\mu\text{F}$$

$$C_{\text{eq}} = \frac{6}{7}\mu\text{F}$$

(ii)

Charge drawn from the source

$$Q = C_{\text{eq}} V$$

$$\frac{6}{7} \times 7\mu\text{C} = 6\mu\text{C}$$

Energy stored in the network, $U = \frac{Q^2}{2C}$

$$\frac{6 \times 6 \times 10^{-12} \times 7}{2 \times 6 \times 10^{-6}} J = 21 \times 10^{-6} J$$

$$= 21 \mu\text{J}$$

Q. 8. Two parallel plate capacitors X and Y have the same area of plates and same separation between them. X has air between the plates while Y contains a dielectric medium $\epsilon_r = 4$. [CBSE Delhi 2016]

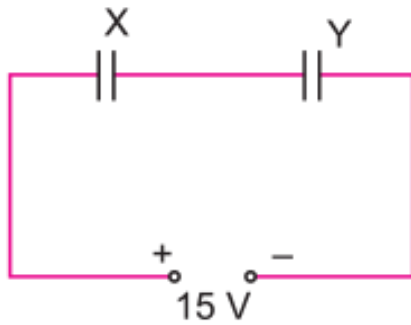

(i) Calculate the capacitance of each capacitor if equivalent capacitance of the combination is $4 \mu\text{F}$.

(ii) Calculate the potential difference between the plates of X and Y.

(iii) Estimate the ratio of electrostatic energy stored in X and Y.

Ans. (i)

$$\text{Capacitance of } X, C_X = \frac{\epsilon_0 A}{d}$$

$$\text{Capacitance of } Y, C_Y = \frac{\epsilon_r \epsilon_0 A}{d} = 4 \frac{\epsilon_0 A}{d}$$

$$\therefore \frac{C_Y}{C_X} = 4 \Rightarrow C_Y = 4C_X \quad \dots(i)$$

As X and Y are in series, so

$$C_{\text{eq}} = \frac{C_X C_Y}{C_X + C_Y} \Rightarrow 4\mu\text{F} = \frac{C_X \cdot 4C_X}{C_X + 4C_X}$$

$$\Rightarrow C_X = 5\mu\text{F} \text{ and } C_Y = 4C_X = 20\mu\text{F}$$

(ii)

In series charge on each capacitor is same, so

$$\text{P.d. } V = \frac{Q}{C} \Rightarrow V \propto \frac{1}{C}$$

$$\therefore \frac{V_x}{V_y} = \frac{C_y}{C_x} = 4 \Rightarrow V_x = 4V_y \quad \dots(ii)$$

$$\text{Also } V_X + V_Y = 15$$

(iii)

From (i) and (ii),

$$4V_Y + V_Y = 15 \Rightarrow V_Y = 3$$

$$V_X = 15 - 3 = 12 \text{ V}$$

Thus potential difference across X, $V_X = 12 \text{ V}$, P.d. across Y, $V_Y = 3 \text{ V}$

$$(iii) \frac{\text{Energy stored in X}}{\text{Energy stored in Y}} = \frac{Q^2/2C_x}{Q^2/2C_y} = \frac{C_y}{C_x} = \frac{4}{1} \Rightarrow \frac{U_x}{U_y} = \frac{4}{1}$$

Q. 9. In a parallel plate capacitor with air between the plates, each plate has an area of $5 \times 10^{-3} \text{ m}^2$ and the separation between the plates is 2.5 mm.[CBSE (F) 2014]

(i) Calculate the capacitance of the capacitor.

(ii) If this capacitor is connected to 100 V supply, what would be the charge on each plate?

(iii) How would charge on the plates be affected, if a 2.5 mm thick mica sheet of $K = 8$ is inserted between the plates while the voltage supply remains connected?

Ans. (i)

$$\begin{aligned} \text{Capacitance, } C &= \frac{\epsilon_0 A}{d} \\ &= \frac{8.85 \times 10^{-12} \times 5 \times 10^{-3}}{25 \times 10^{-3}} \\ &= 17.7 \times 10^{-12} \text{ F} \end{aligned}$$

(ii) Charge $Q = CV$

$$= 17.7 \times 10^{-12} \times 100$$

$$= 17.7 \times 10^{-10} \text{ C}$$

(iii) New charge, $Q = KQ$

$$= 8 \times 17.7 \times 10^{-10}$$

$$= 1.416 \times 10^{-8} \text{ C}$$

Q. 10. A capacitor of unknown capacitance is connected across a battery of V volts. The charge stored in it is $360 \mu\text{C}$. When potential across the capacitor is reduced by 120 V , the charge stored in it becomes $120 \mu\text{C}$.

Calculate:

(i) The potential V and the unknown capacitance C .

(ii) What will be the charge stored in the capacitor, if the voltage applied had increased by 120 V ? [CBSE Delhi 2013]

Ans.



If unknown capacitor of capacitance ' C ' is connected to a battery of ' V ' volts,

$$Q = CV$$

$$\Rightarrow CV = 360 \mu\text{C} \quad \dots\text{(i)}$$

On reducing the potential/voltage by 120 V

$$\text{So, } Q' = C(V - 120)$$

$$\Rightarrow C(V - 120) = 120 \mu\text{C} \quad \dots\text{(ii)}$$

On solving equation (i) and (ii)

$$\frac{360 \mu C}{V} = \frac{120 \mu C}{V - 120}$$

$$\Rightarrow V = 180 V$$

Unknown capacitance from equation (i)

$$Q = CV$$

$$360 \mu C = C \times 180 V$$

$$\Rightarrow C = \frac{360 \mu C}{180 V} = 2$$

$$\Rightarrow C = 2 \mu F$$

ii. Charge on the capacitor, if voltage is increased by 120V

$$Q = C (V + 120) = 2 (180 + 120) = 600 \mu C$$

Q. 11. A parallel plate capacitor of capacitance C is charged to a potential V . It is then connected to another uncharged capacitor having the same capacitance. Find out the ratio of the energy stored in the combined system to that stored initially in the single capacitor.

[CBSE (AI) 2014]

Ans.

$$\text{Energy stored in the capacitor} = \frac{1}{2} CV^2 = \frac{q^2}{2C}$$

Net capacitance of the parallel combination (when capacitors are connected together)

$$= C + C = 2C$$

Since the total charge Q remains same initial energy = $\frac{q^2}{2C}$

$$\text{Final energy} = \frac{q^2}{2(2C)}$$

$$\frac{U_f}{U_i} = 1 : 2$$

Q. 12. Calculate the equivalent capacitance between points A and B in the circuit below. If a battery of 10 V is connected across A and B, calculate the charge drawn from the battery by the circuit. [CBSE East 2016]

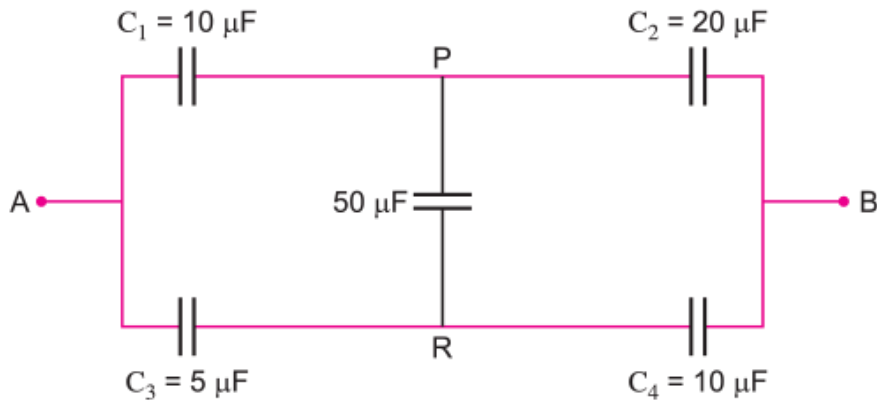

Ans. $\therefore \frac{C_1}{C_3} = \frac{C_2}{C_4}$

This is the condition of balance so there will be no current across PR (50 μF capacitor)

Now C_1 and C_2 are in series

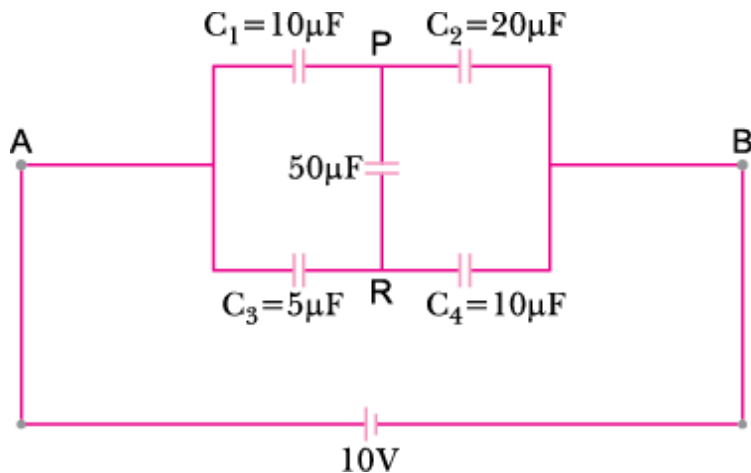

$$C_{12} = \frac{C_1 C_2}{C_1 + C_2} = \frac{10 \times 20}{10 + 20} = \frac{200}{30} = \frac{20}{3} \mu F$$

∴ C_3 and C_4 are in series

$$C_{34} = \frac{C_3 C_4}{C_3 + C_4} = \frac{5 \times 10}{5 + 10} = \frac{50}{15} = \frac{10}{3} \mu F$$

Equivalent capacitance between A and B is

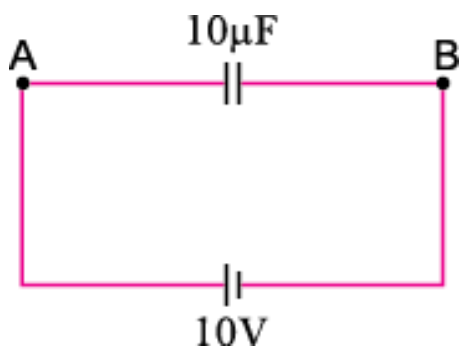

$$C_{AB} = C_{12} + C_{34} = \frac{20}{3} + \frac{10}{3} = 10 \mu F$$

Hence, charge drawn from battery (Q) = CV

$$= 10 \times 10 \mu C = 100 \mu C = 10^{-4} C$$

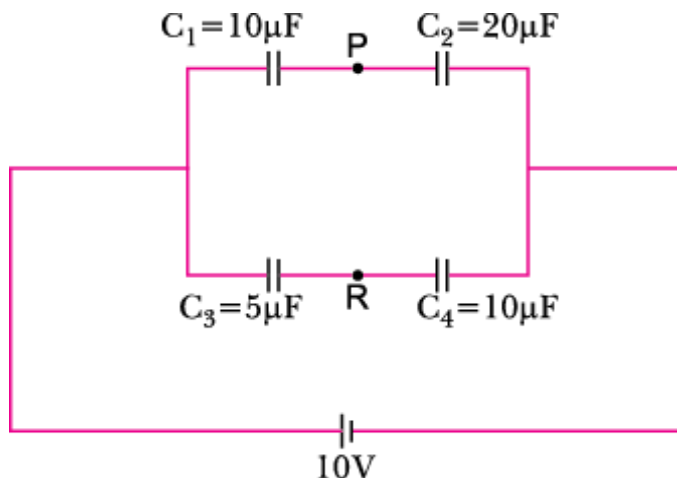

Q. 13. Two capacitors of unknown capacitances C_1 and C_2 are connected first in series and then in parallel across a battery of $100 V$. If the energy stored in the two combinations is $0.045 J$ and $0.25 J$ respectively, determine the value of C_1 and C_2 . Also calculate the charge

on each capacitor in parallel combination.
[CBSE Delhi 2015]

Ans.

Energy stored in a capacitor, $E = \frac{1}{2} CV^2$

In parallel, $0.25 = \frac{1}{2} (C_1 + C_2) (100)^2 \quad \dots(i)$

In series, $0.045 = \frac{1}{2} \left(\frac{C_1 C_2}{C_1 + C_2} \right) (100)^2 \quad \dots(ii)$

From (i) $C_1 + C_2 = 0.25 \times 2 \times 10^{-4}$

$$C_1 + C_2 = 5 \times 10^{-5} \quad \dots(iii)$$

From (ii) $\frac{C_1 C_2}{C_1 + C_2} = 0.045 \times 2 \times 10^{-4}$

$$\frac{C_1 C_2}{C_1 + C_2} = 0.09 \times 10^{-4} = 9 \times 10^{-6}$$

From (iii) $C_1 C_2 = \frac{2 \times 0.045 \times 5 \times 10^{-5}}{10^4} = 4.5 \times 10^{-10}$

$$C_1 - C_2 = \sqrt{(C_1 + C_2)^2 - 4C_1 C_2}$$

$$C_1 - C_2 = 2.64 \times 10^{-5} \quad \dots(iv)$$

Solving (iii) and (iv) $C_1 = 38.2 \mu\text{F}$

$C_2 = 11.8 \mu\text{F}$

In parallel $Q_1 = C_1 V$

$$= 38.2 \times 10^{-6} \times 100 = 38.2 \times 10^{-4} \text{ C}$$

$Q_2 = C_2 V$

$$= 11.8 \times 10^{-6} \times 100 = 11.8 \times 10^{-4} \text{ C}$$

Q. 14. Two capacitors of capacitance $10 \mu\text{F}$ and $20 \mu\text{F}$ are connected in series with a 6 V battery. After the capacitors are fully charged, a slab of dielectric constant (K) is inserted between the plates of the two capacitors. How will the following be affected after the slab is introduced:

- The electric field energy stored in the capacitors?
- The charges on the two capacitors?
- The potential difference between the plates of the capacitors?

Justify your answer. [CBSE Bhubaneswar 2015]

Ans.

Let Q be the charge on each capacitor. So, $Q = \frac{C_1 C_2}{C_1 + C_2} V$

Initial electric field energy in each capacitor becomes

$$U_1 = \frac{1}{2} \frac{Q^2}{C_1} \text{ and } U_2 = \frac{1}{2} \frac{Q^2}{C_2}$$

Initial charge on each capacitor

$$Q = C_1 V_1, Q = C_2 V_2 \text{ and } Q = \frac{C_1 C_2}{C_1 + C_2} \cdot V$$

where V_1 and V_2 are p.d across the capacitors

On inserting the dielectric slab the capacitance of each capacitor becomes

$$C_1 = KC_1 \text{ and } C_2 = KC_2$$

and equivalent capacitance becomes

$$C'_{\text{eq}} = \frac{KC_1 \times KC_2}{KC_1 + KC_2} = K \frac{C_1 C_2}{C_1 + C_2}$$

New charge on the capacitor becomes

$$Q' = C'_{\text{eq}} V' = K \left(\frac{C_1 C_2}{C_1 + C_2} \right) \times V$$

$$Q' = \frac{C_1 C_2}{C_1 + C_2} \cdot V \times K$$

$$Q' = Q \times K$$

$$Q' = KQ$$

a. New electric field energy becomes

$$U'_1 = \frac{Q'^2}{2KC_1} = \frac{KQ^2}{2C_1}$$

$$U'_2 = \frac{1}{2} \frac{Q'^2}{KC_2} = \frac{KQ^2}{2C_2}$$

i.e., electric field energy increases in each capacitor.

b. $Q' = KQ$ (as stated above)

$$c. \quad V'_1 = \frac{Q'}{C'_1} = \frac{KQ}{KC} = \frac{Q}{C_1}$$

$$\text{and } V'_2 = \frac{Q'}{C'_2} = \frac{KQ}{KC_2} = \frac{Q}{C_2} \quad (\text{Remains same})$$

i.e., $p.d$ across each capacitor decreases.

Q. 15. A 12 pF capacitor is connected to a 50 V battery. How much electrostatic energy is stored in the capacitor? If another capacitor of 6 pF is connected in series with it with the same battery connected across the combination, find the charge stored and potential difference across each capacitor. [CBSE Delhi 2017]

Ans.

Electrostatic energy stored, $U = \frac{1}{2}CV^2$

$$\frac{1}{2} \times 12 \times 10^{-12} \times 50 \times 50 J = 1.5 \times 10^{-8} J$$

C = Equivalent capacitance of 12 pF and 6 pF, in series

$$\therefore \frac{1}{C} = \frac{1}{12} + \frac{1}{6} = \frac{1+2}{12}$$

$$\Rightarrow C = 4 \text{ pF}$$

Charge stored across each capacitor

$$Q = CV = 4 \times 10^{-12} \times 50 \text{ V}$$
$$= 2 \times 10^{-10} \text{ C}$$

In series combination, charge on each capacitor is same.

Charge on each capacitor, 12 pF as well as 6 pF is same.

\therefore Potential difference across capacitor C_1 (12 pF capacitor)

$$V_1 = \frac{2 \times 10^{-10}}{12 \times 10^{-12}} V = \frac{50}{3} V \quad \left(V = \frac{Q}{C} \right)$$

Potential difference across capacitor C_2 (6 pF capacitor)

$$V_2 = \frac{2 \times 10^{-10}}{6 \times 10^{-12}} V = \frac{100}{3} V$$

Q. 16. Two identical capacitors of 12 pF each are connected in series across a battery of 50 V. How much electrostatic energy is stored in the combination? If these were connected in parallel across the same battery, how much energy will be stored in the combination now?

Also find the charge drawn from the battery in each case. [CBSE Delhi 2017]

Ans.

In series combination: $\frac{1}{C_s} = \left(\frac{1}{12} + \frac{1}{12}\right) \Rightarrow \frac{1}{C_s} = \frac{1}{6}$

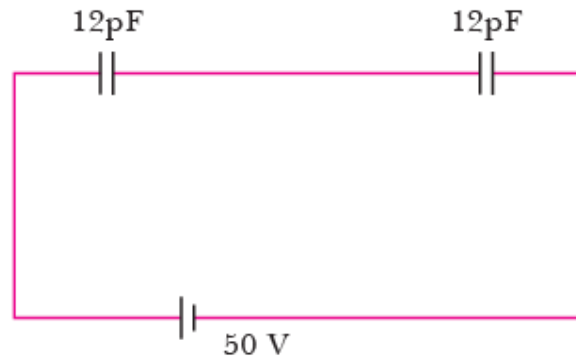

$$\therefore C_s = 6 \times 10^{-12} \text{ F}$$

$$U_s = 6 \times 10^{-12} \text{ F}$$

$$U_s = \frac{1}{2} CV^2$$

$$\therefore U_s = 75 \times 10^{-10} \text{ J}$$

$$Q_s = C_s V = 6 \times 10^{-12} \times 50$$

$$= 300 \times 10^{-12} \text{ C} = 3 \times 10^{-10} \text{ C}$$

In parallel combination: $C_p = (12 + 12) \text{ pF}$

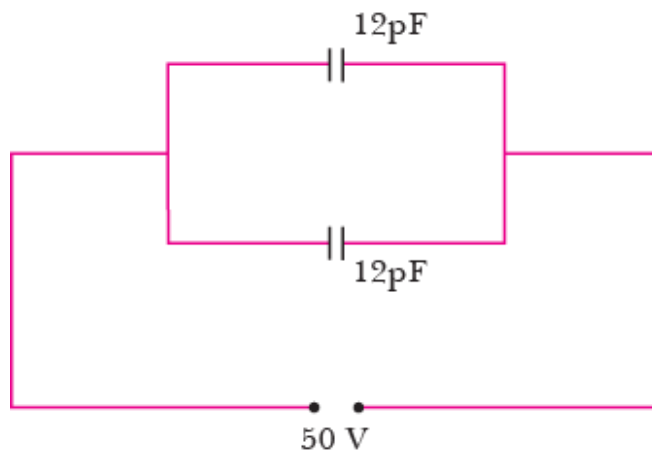

$$\therefore C_p = 24 \times 10^{-12} \text{ F}$$

$$U_s = \frac{1}{2} \times 24 \times 10^{-12} \times 2500 \text{ J}$$

$$= 3 \times 10^{-8} \text{ J}$$

$$Q_p = C_p V$$

$$Q_p = 24 \times 10^{-12} \times 50 \text{ C}$$

$$Q_p = 1.2 \times 10^{-9} \text{ C}$$

Q. 17. In the given circuit in the steady state, obtain the expression for (a) the potential drop (b) the charge and (c) the energy stored in the capacitor, C. [CBSE (F) 2015]

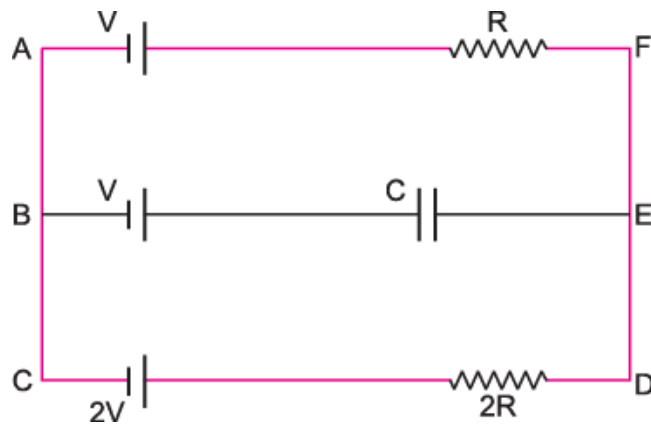

Ans. a. In steady state BE will behave as open circuit.

In steady state, current in the circuit ACDFA

$$I = \frac{2V - V}{2R + R} = \frac{V}{3R}$$

Potential at point E, assuming

$$\text{Potential difference across EB} = 2V - 2IR = 2V - 2R \times \frac{V}{3R} = \frac{4V}{3}$$

$$\text{Potential difference across capacitor} = \frac{4V}{3} - V = \frac{V}{3}$$

Hence, potential drop across the capacitor is $\frac{V}{3}$

b. Charge on the capacitor $q = C \left(\frac{V}{3} \right) = \frac{1}{3} CV$

c. Energy stored in the capacitor $U = \frac{1}{2} C \left(\frac{V}{3} \right)^2 = \frac{1}{18} CV^2$

Q. 18. Calculate the potential difference and the energy stored in the capacitor C_2 in the circuit shown in the figure. Given potential at A is 90 V, $C_1 = 20 \mu\text{F}$, $C_2 = 30 \mu\text{F}$, $C_3 = 15 \mu\text{F}$. [CBSE Allahabad 2015]

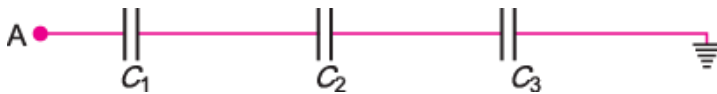

Ans. Capacitors C_1 , C_2 and C_3 are in series. So, its net capacitance is

$$\frac{1}{C_s} = \frac{1}{C_1} + \frac{1}{C_2} + \frac{1}{C_3} = \frac{1}{20} + \frac{1}{30} + \frac{1}{15}$$

$$C_s = \frac{20}{3} \mu\text{F}$$

Net charge on the capacitors, C_1 , C_2 and C_3 remain same.

$$q = C_s (V_A - V_E)$$

$$= \frac{20}{3} \mu F \times (90 - 0) = 600 \mu C$$

The *p.d* across C_2 due to charge $600 \mu C$ is

$$V_2 = \frac{q}{C_2} = \frac{600}{30} = 20 V$$

Energy stored in the capacitor C_2 ,

$$U_2 = \frac{1}{2} \frac{q^2}{C_2} \text{ (or } \frac{1}{2} C_2 V_2^2 \text{)}$$

$$= \frac{1}{2} \times 30 \mu F \times (20)^2 = 6000 \mu J = 6 \times 10^{-3} J$$

Q. 19. In the following arrangement of capacitors, the energy stored in the $6 \mu F$ capacitor is **E**. Find the value of the following:

(i) Energy stored in $12 \mu F$ capacitor.

(ii) Energy stored in $3 \mu F$ capacitor.

(ii) Total energy drawn from the battery [CBSE (F) 2016]

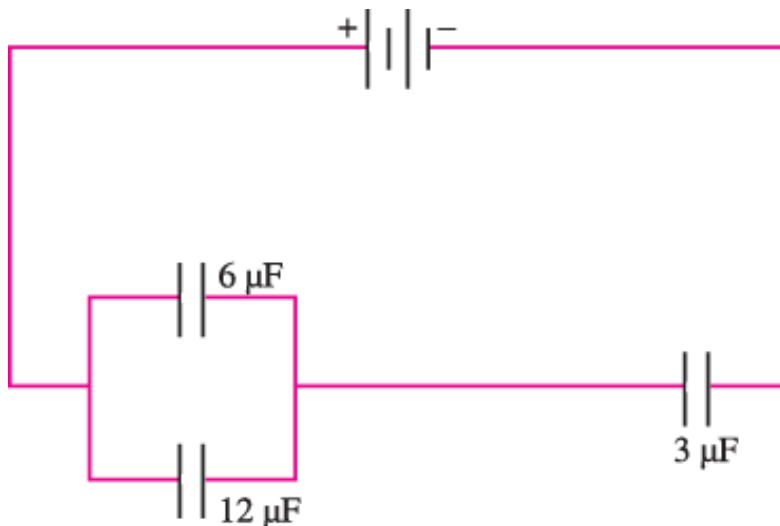

Ans. Given that energy stored in $6 \mu F$ is **E**.

Let V be the voltage across $6 \mu F$ capacitor

Also, $6 \mu F$ and $12 \mu F$ capacitors are in parallel.

Therefore, voltage across $12 \mu F =$ Voltage across $6 \mu F$ capacitor

$$E = \frac{1}{2} CV^2 = \frac{1}{2} \times 6 \times V^2 \Rightarrow V = \sqrt{\frac{E}{3}}$$

$$\text{Energy stored in } 12 \mu F = \frac{1}{2} \times 12 \times \left(\sqrt{\frac{E}{3}}\right)^2 = 2E$$

ii. Since charge remains constant in series. Sum of charge on 6 μF capacitor and 12 μF capacitor is equal to charge on 3 μF capacitor.

Using $Q = CV$,

$$\text{Charge on 3 } \mu F \text{ capacitor} = (6 + 12) \times V = 18 \times V$$

$$\text{Energy stored in 3 } \mu F \text{ capacitor} = \frac{Q^2}{2C} = \frac{(18V)^2}{2 \times 3} = \frac{18 \times 18}{6} \left(\frac{\sqrt{E}}{3}\right)^2 = 18E$$

iii. Total energy drawn from battery = $E + 2E + 18E = 21E$

Q. 20. Two identical parallel plate (air) capacitors C_1 and C_2 have capacitances C each. The space between their plates is now filled with dielectrics as shown. If the two capacitors still have equal capacitance, obtain the relation between dielectric constants K , K_1 and K_2 .

[Hots] [CBSE (F) 2011]

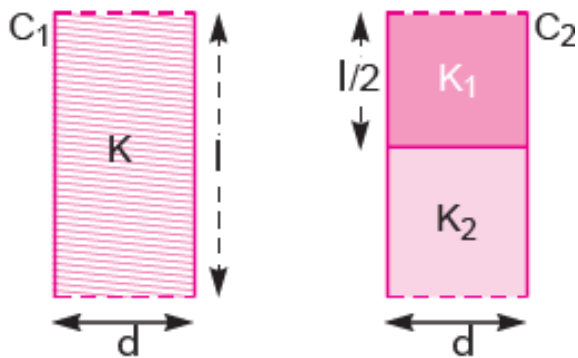

Ans.

Let $A \rightarrow$ area of each plate.

$$\text{Let initially } C_1 = C = \frac{\epsilon_0 A}{d} = C_2 \quad \dots(i)$$

After inserting respective dielectric slabs:

$$\text{and } C'_2 = K_1 \frac{\epsilon_0 (A/2)}{d} + \frac{K_2 \epsilon_0 (A/2)}{d} = \frac{\epsilon_0 A}{2d} (K_1 + K_2)$$

$$C'_2 = \frac{C}{2} (K_1 + K_2) \quad \dots(ii)$$

From (i) and (ii)

$$C'_1 = C'_2 \Rightarrow KC = \frac{C}{2} (K_1 + K_2) \Rightarrow K = \frac{1}{2} (K_1 + K_2)$$

Q. 21. You are given an air filled parallel plate capacitor C_1 . The space between its plates is now filled with slabs of dielectric constants K_1 and K_2 as shown in C_2 . Find the capacitances of the capacitor C_2 , if area of the plates is A and distance between the plates is d . [Hots] [CBSE (F) 2011]

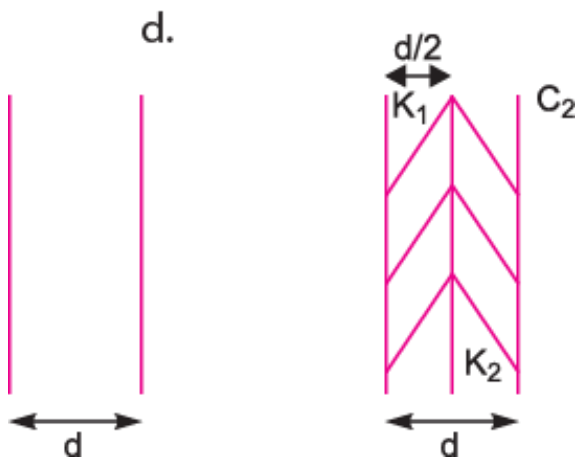

Ans. B

$$C_1 = \frac{\epsilon_0 A}{d}$$

$$\frac{1}{C_2} = \frac{1}{K_1 \frac{\epsilon_0 A}{d/2}} + \frac{1}{K_2 \frac{\epsilon_0 A}{d/2}}$$

$$= \frac{d}{2.K_1 \epsilon_0 A} + \frac{d}{2.K_2 \epsilon_0 A}$$

$$\frac{1}{C_2} = \frac{d}{2\epsilon_0 A} \left[\frac{1}{K_1} + \frac{1}{K_2} \right] \Rightarrow C_2 = \frac{2.\epsilon_0 A}{d} \left[\frac{K_1 K_2}{K_1 + K_2} \right]$$

$$C_2 = 2C_1 \left[\frac{K_1 K_2}{K_1 + K_2} \right] \Rightarrow C_2 = C_1 \left[\frac{2K_1 K_2}{K_1 + K_2} \right]$$

Q. 22. A slab of material of dielectric constant K has the same area as that of the plates of a parallel plate capacitor but has the thickness $d/2$, where d is the separation between the plates. Find out the expression for its capacitance when the slab is inserted between the plates of the capacitor. [Hots] [CBSE (AI) 2013]

Ans.

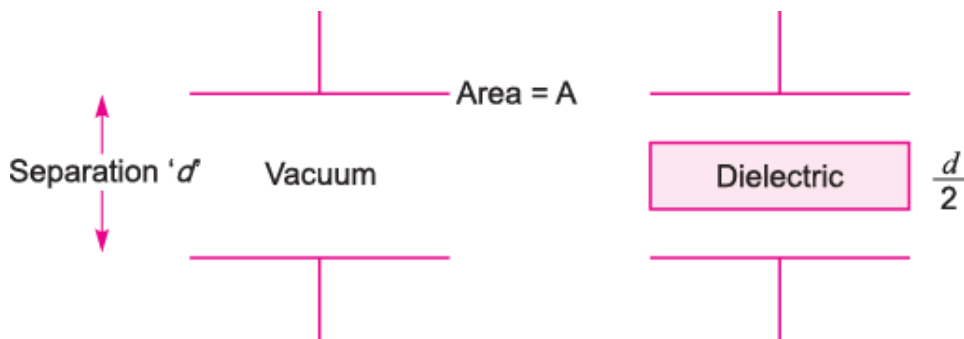

Capacitance with dielectric of thickness 't'

$$C = \frac{\epsilon_0 A}{d-t+\frac{t}{K}} \quad \text{Put } t = \frac{d}{2}$$

$$C = \frac{\epsilon_0 A}{d-\frac{d}{2}+\frac{d}{2K}} = \frac{\epsilon_0 A}{\frac{d}{2}+\frac{d}{2K}} \Rightarrow \frac{\epsilon_0 A}{\frac{d}{2}\left(1+\frac{1}{K}\right)} = \frac{2\epsilon_0 AK}{d(K+1)}$$

Q. 23. Two identical parallel plate capacitors A and B are connected to a battery of V volts with the switch S closed. The switch is now opened and the free space between the plates of the capacitors is filled with a dielectric of dielectric constant K . Find the ratio of the total electrostatic energy stored in both capacitors before and after the introduction of the dielectric. [CBSE (AI) 2017]

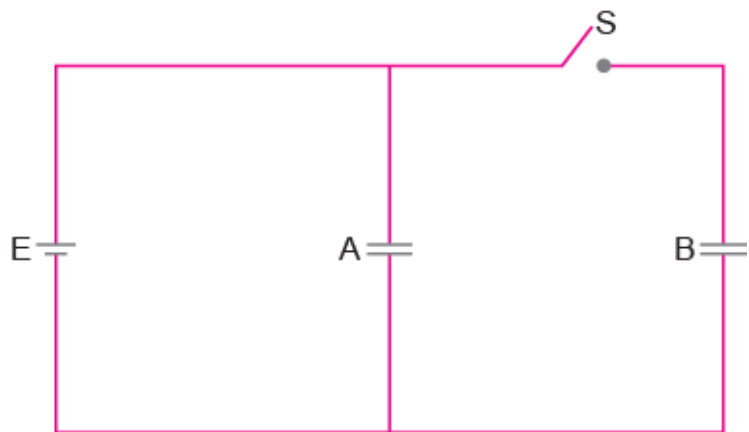

Ans. Two capacitors are connected in parallel. Hence, the potential on each of them remains the same. So, the charge on each capacitor is

$$Q_A = Q_B = CV$$

$$\text{Formula for energy stored} = \frac{1}{2} CV^2 = \frac{1}{2} \frac{Q^2}{C}$$

$$\text{Net capacitance with switch S closed} = C + C = 2C$$

$$\therefore \text{Energy stored} = \frac{1}{2} \times 2C \times V^2 = CV^2$$

After the switch S is opened, capacitance of each capacitor = $\frac{C}{2}$

In this case, voltage only across A remains the same.

The voltage across B changes to $V' = \frac{Q}{C'} = \frac{Q}{KC}$

\therefore Energy stored in capacitor A = $\frac{1}{2}KCV^2$

Energy stored in capacitor B = $\frac{1}{2} \frac{Q^2}{KC} = \frac{1}{2} \frac{C^2V^2}{KC} = \frac{1}{2} \frac{CV^2}{K}$

\therefore Total energy stored = $\frac{1}{2}KCV^2 + \frac{1}{2} \frac{CV^2}{K}$

$$\frac{1}{2}CV^2 \left(K + \frac{1}{K}\right)$$

$$\frac{1}{2}CV^2 \left(\frac{K^2+1}{K}\right)$$

Required ratio = $\frac{2CV^2 \cdot K}{CV^2 (K^2+1)} = \frac{2K}{(K^2+1)}$

Long Answer Questions

Q. 1. Briefly explain the principle of a capacitor. Derive an expression for the capacitance of a parallel plate capacitor, whose plates are separated by a dielectric medium.

Ans. Principle of a Capacitor: A capacitor works on the principle that the capacitance of a conductor increases appreciably when an earthed conductor is brought near it.

Parallel Plate Capacitor: Consider a parallel plate capacitor having two plane metallic plates A and B, placed parallel to each other (see fig.). The plates carry equal and opposite charges $+Q$ and $-Q$ respectively.

In general, the electric field between the plates due to charges $+Q$ and $-Q$ remains uniform, but at the edges, the electric field lines deviate outward. If the separation between the plates is much smaller than the size of plates, the electric field strength between the plates may be assumed uniform.

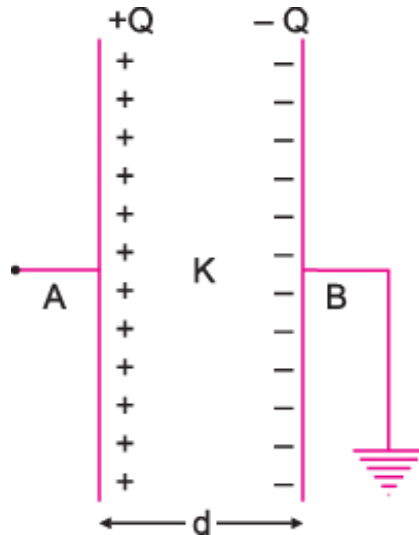

Let A be the area of each plate, ' d ' the separation between the plates, K the dielectric constant of medium between the plates. If σ is the magnitude of charge density of plates, then

$$\sigma = \frac{Q}{A}$$

The electric field strength between the plates

$$E = \frac{\sigma}{K\epsilon_0} \text{ where } \epsilon_0 \text{ permittivity of free space.} \quad \dots(i)$$

$$\text{The potential difference between the plates, } V_{AB} = Ed = \frac{\sigma d}{K\epsilon_0} \quad \dots(ii)$$

Putting the value of σ , we get

$$V_{AB} = \frac{(Q/A)d}{K\epsilon_0} = \frac{\sigma d}{K\epsilon_0 A}$$

\therefore Capacitance of capacitor,

$$C = \frac{Q}{V_{AB}} = \frac{Q}{(Qd/K\epsilon_0 A)} \text{ OR } C = \frac{K\epsilon_0 A}{d} \quad \dots(iii)$$

This is a general expression for capacitance of parallel plate capacitor. Obviously, the capacitance is directly proportional to the dielectric constant of medium between the plates.

$$C = \frac{\epsilon_0 A}{d}$$

For air capacitor ($K=1$); capacitance. This is expression for the capacitance of a parallel plate air capacitor. It can be seen that the capacitance of parallel plate (air) capacitor is:

- (a) Directly proportional to the area of each plate.
- (b) Inversely proportional to the distance between the plates.
- (c) Independent of the material of the plates.

Q. 2. Derive an expression for the capacitance of a parallel plate capacitor when a dielectric slab of dielectric constant K and thickness $t = \frac{d}{2}$ but of same area as that of the plates is inserted between the capacitor plates. (d = separation between the plates). [CBSE (F) 2010]

Ans. Consider a parallel plate capacitor, area of each plate being – A , the separation between the plates being d . Let a dielectric slab of dielectric constant K and thickness $t < d$ be placed between the plates. The thickness of air between the plates is $(d - t)$. If charges on plates are $+Q$ and $-Q$, then surface charge density

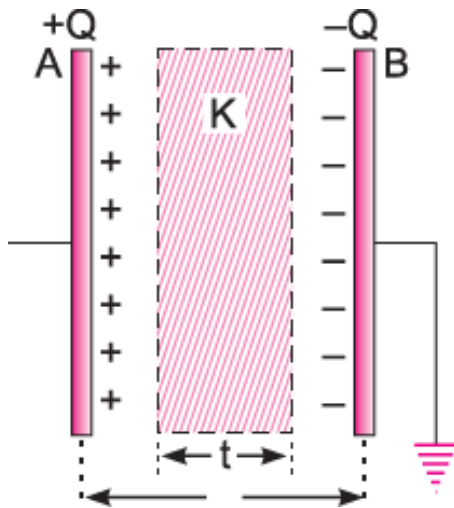

$$\sigma = \frac{Q}{A}$$

The electric field between the plates in air, $E_1 = \frac{\sigma}{\epsilon_0} = \frac{Q}{\epsilon_0 A}$

The electric field between the plates in slab, $E_2 = \frac{\sigma}{K\epsilon_0} = \frac{Q}{K\epsilon_0 A}$

\therefore The potential difference between the plates

V_{AB} = work done in carrying unit positive charge from one plate to another

= $\sum E dx$ (as field between the plates is not constant).

$$= E_1(d-t) + E_2 t = \frac{Q}{\epsilon_0 A} (d-t) + \frac{Q}{K\epsilon_0 A} t$$

$$\therefore \therefore V_{AB} = \frac{Q}{\epsilon_0 A} \left[d - t + \frac{t}{K} \right]$$

$$\therefore \text{Capacitance of capacitor, } C = \frac{Q}{V_{AB}} = \frac{Q}{\frac{Q}{\epsilon_0 A} \left(d - t + \frac{t}{K} \right)}$$

$$\text{or, } C = \frac{\epsilon_0 A}{d - t + \frac{t}{K}} = \frac{\epsilon_0 A}{d - t \left(1 - \frac{1}{K} \right)}$$

$$\text{Here, } t = \frac{d}{2} \quad \therefore C = \frac{\epsilon_0 A}{d - \frac{d}{2} \left(1 - \frac{1}{K} \right)} = \frac{\epsilon_0 A}{\frac{d}{2} \left(1 + \frac{1}{K} \right)}$$

Q. 3. Derive an expression for the energy stored in a parallel plate capacitor C, charged to a potential difference V. Hence derive an expression for the energy density of a capacitor. [CBSE (AI) 2012, (F) 2013, Allahabad 2015]

OR

Obtain an expression for the energy stored per unit volume in a charged parallel plate capacitor.

b. Find the ratio of the potential differences that must be applied across the parallel and series combination of two capacitors C_1 and C_2 with their capacitances in the ratio 1 : 2 so that the energy stored in the two cases becomes the same.

[CBSE Central 2016]

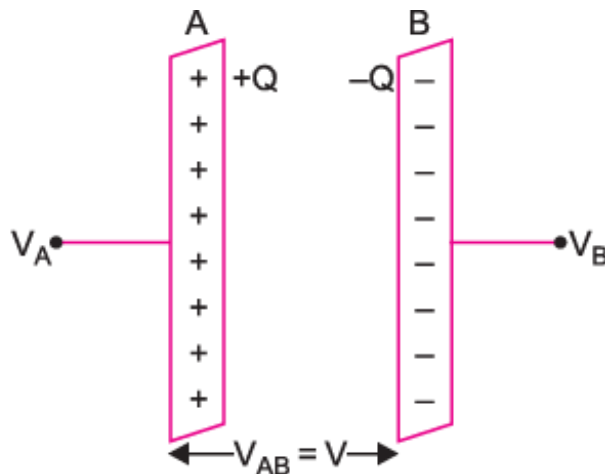

Ans. (a) When a capacitor is charged by a battery, work is done by the charging battery at the expense of its chemical energy. This work is stored in the capacitor in the form of electrostatic potential energy.

Consider a capacitor of capacitance C . Initial charge on capacitor is zero. Initial potential difference between capacitor plates is zero. Let a charge Q be given to it in small steps. When charge is given to capacitor, the potential difference between its plates increases. Let at any instant when charge on capacitor be q , the potential

difference between its plates $V = \frac{q}{C}$

Now work done in giving an additional infinitesimal charge dq to capacitor.

$$dW = V dq = \frac{q}{C} dq$$

The total work done in giving charge from 0 to Q will be equal to the sum of all such infinitesimal works, which may be obtained by integration. Therefore total work

$$W = \int_0^Q V dq = \int_0^Q \frac{q}{C} dq = \frac{1}{C} \left[\frac{q^2}{2} \right]_0^Q = \frac{1}{C} \left(\frac{Q^2}{2} - \frac{0}{2} \right) = \frac{Q^2}{2C}$$

If V is the final potential difference between capacitor plates, then $Q=CV$

$$\therefore W = \frac{(CV)^2}{2C} = \frac{1}{2} CV^2 = \frac{1}{2} QV$$

This work is stored as electrostatic potential energy of capacitor i.e.,

$$\text{Electrostatic potential energy, } U = \frac{Q^2}{2C} = \frac{1}{2} CV^2 = \frac{1}{2} QV$$

Energy density: Consider a parallel plate capacitor consisting of plates, each of area A, separated by a distance d. If space between the plates is filled with a medium of dielectric constant K, then

$$\text{Capacitance of capacitor, } C = \frac{K\epsilon_0 A}{d}$$

If σ is the surface charge density of plates, then electric field strength between the plates.

$$E = \frac{\sigma}{K\epsilon_0} \Rightarrow \sigma = K\epsilon_0 E$$

$$\text{Charge on each plate of capacitor, } Q = \sigma A = K\epsilon_0 EA$$

$$\text{Energy stored by capacitor, } U = \frac{Q^2}{2C} = \frac{(K\epsilon_0 EA)^2}{2(K\epsilon_0 A/d)} = \frac{1}{2} K\epsilon_0 E^2 Ad$$

But Ad = volume of space between capacitor plates

$$\therefore \text{Energy stored, } U = \frac{1}{2} K\epsilon_0 E^2 Ad$$

$$\text{Electrostatic Energy stored per unit volume, } u_e = \frac{U}{Ad} = \frac{1}{2} K\epsilon_0 E^2$$

This is expression for electrostatic energy density in medium of dielectric constant K.

In air or free space ($K=1$) therefore energy density, $u_e = \frac{1}{2} \epsilon_0 E^2$

$$\text{b. } U_S = \frac{1}{2} C_S V_S^2 \quad \Rightarrow \quad U_P = \frac{1}{2} C_P V_P^2$$

$$\text{Also, } \frac{C_1}{C_2} = \frac{1}{2} \text{ (given)} \Rightarrow C_2 = 2C_1$$

$$\Rightarrow \frac{V_{\text{series}}}{V_{\text{parallel}}} = \sqrt{\frac{C_{\text{equivalent parallel}}}{C_{\text{equivalent series}}}}$$

$$= \sqrt{\frac{\frac{C_1 + C_2}{C_1 C_2}}{C_1 + C_2}}$$

$$= \frac{C_1 + C_2}{\sqrt{C_1 C_2}} = \frac{3C_1}{\sqrt{2C_1^2}} = \frac{3}{\sqrt{2}}$$

Q. 4. Find the expression for the energy stored in the capacitor. Also find the energy lost when the charged capacitor is disconnected from the source and connected in parallel with the uncharged capacitor. Where does this loss of energy appear?

[CBSE Sample Paper 2017]

Ans.

$$Q = Q_1 + Q_2$$

$V_1 = V_2$ potential of both capacitors after they are connected with each other.

$$\therefore \frac{Q_1}{C_1} = \frac{Q_2}{C_2} \Rightarrow Q = \left(\frac{C_1}{C_2} + 1 \right) Q_2$$

$$Q_2 = \frac{QC_2}{C_1 + C_2} \quad Q_1 = \frac{QC_1}{C_1 + C_2}$$

$$V_2 = V_1 = \frac{Q}{C_1 + C_2} = \frac{Q_2}{C_2} = \frac{Q_1}{C_1}$$

$$U_f = \frac{1}{2} C_1 V_1^2 + \frac{1}{2} C_2 V_2^2 = \frac{1}{2} (C_1 + C_2) \frac{Q^2}{(C_1 + C_2)^2} = \frac{Q^2}{2(C_1 + C_2)}$$

$$U_i = \frac{Q^2}{2C_1}$$

$$U_i - U_f = \frac{Q^2}{2C_1} - \frac{Q^2}{2(C_1 + C_2)} = \frac{Q^2(C_2)}{(C_1)(C_1 + C_2)}$$

The lost energy appears in the form of heat.

Q. 5. Answer the following questions

(i) Distinguish, with the help of a suitable diagram, the difference in the behaviour of a conductor and a dielectric placed in an external electric field. How does polarised dielectric modify the original external field?

(ii) A capacitor of capacitance C is charged fully by connecting it to a battery of emf E . It is then disconnected from the battery. If the separation between the plates of the capacitor is now doubled, how will the following change?

- (a) Charge stored by the capacitor.
- (b) Field strength between the plates.
- (c) Energy stored by the capacitor.

Justify your answer in each case. [CBSE North 2016]

Ans. (i)

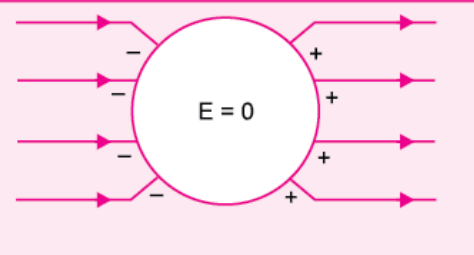
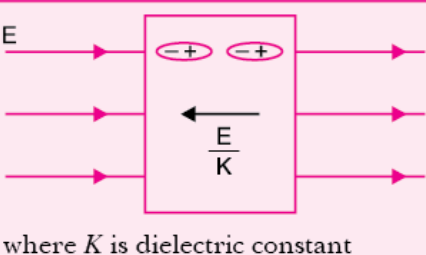
	Conductor	Dielectric
		 <p>where K is dielectric constant</p>
1.	No electric field lines travel inside conductor.	1. Alignment of atoms takes place due to electric field.
2.	Electric field inside a conductor is zero.	2. This results in a small electric field inside dielectric in opposite direction. Net field inside the dielectric is $\frac{E}{K}$.

Induced electric field, due to polarisation of dielectric, is in opposite direction to the applied field.

$$E_{\text{net}} = E_0 - E_p$$

(ii) (a) Charge remains same, as after disconnecting capacitor no transfer of charge take place.

(b) Electric field, $E = \frac{\sigma}{\epsilon_0} = \frac{q}{\epsilon_0 A}$ remain same, as there is no change in charge.

$$\text{Energy stored} = \frac{q^2}{2C} = \frac{q^2}{2\left(\frac{\epsilon_0 A}{d}\right)} = \frac{q^2 d}{2\epsilon_0 A}$$

(c)

Energy will be doubled as separation between the plates (d) is doubled.

Q. 6. Answer the following questions

(i) Explain why, for any charge configuration, the equipotential surface through a point is normal to the electric field at that point.

Draw a sketch of equipotential surfaces due to a single charge ($-q$), depicting the electric field lines due to the charge.

(ii) Obtain an expression for the work done to dissociate the system of three charges placed at the vertices of an equilateral triangle of side 'a' as shown alongside.

[CBSE North 2016]

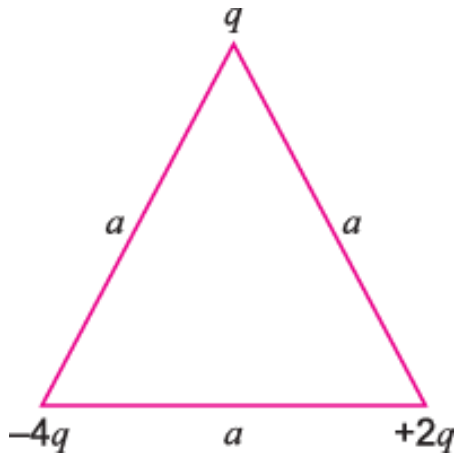

Ans. The work done in moving a charge from one point to another on an equipotential surface is zero. If the field is not normal to an equipotential surface, it would have a non-zero component along the surface. This would imply that work would have to be done to move a charge on the surface which is contradictory to the definition of equipotential surface.

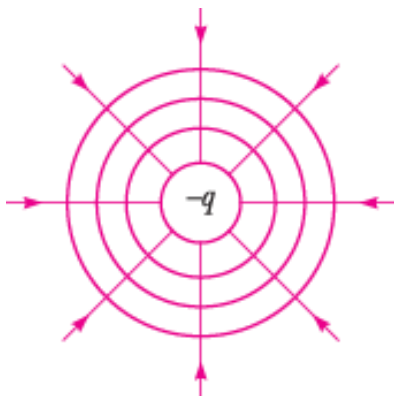

Mathematically

Work done to move a charge dq , on a surface, can be expressed as

$$dW = dq(\vec{E} \cdot \vec{dr})$$

But $dW = 0$ on an equipotential surface

$$\therefore \vec{E} \perp \vec{dr}$$

Equipotential surfaces for a charge $-q$ is shown alongside.

Q. 7. Answer the following questions.

(i) Derive an expression for equivalent capacitance of three capacitors when connected in series

(ii) Derive an expression for equivalent capacitance of three capacitors when connected in parallel.

Ans. In fig. (a) Three capacitors of capacitances C_1, C_2, C_3 are connected in series between points A and D.

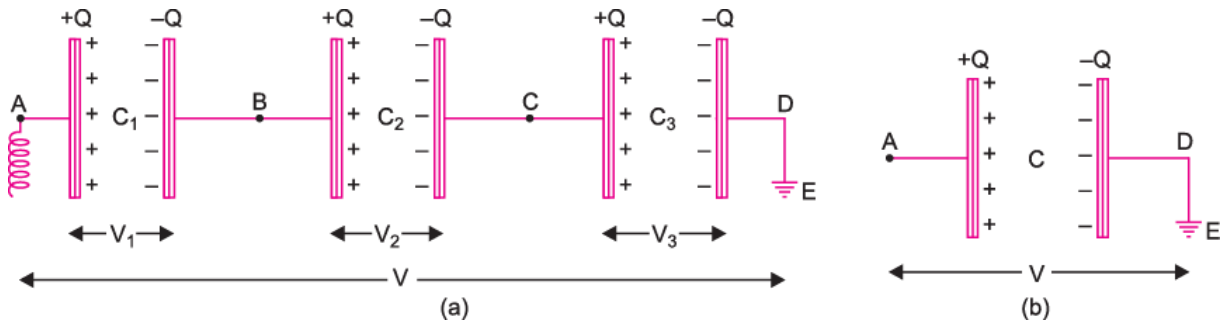

In series' first plate of each capacitor has charge $+Q$ and second plate of each capacitor has charge $-Q$ i.e., charge on each capacitor is Q .

Let the potential differences across the capacitors C_1, C_2, C_3 be V_1, V_2, V_3 respectively. As the second plate of first capacitor C_1 and first plate of second capacitor C_2 are connected together, their potentials are equal. Let this common potential be V_B . Similarly the common potential of second plate of C_2 and first plate of C_3 is V_C . The second plate of capacitor C_3 is connected to earth, therefore its potential $V_D=0$. As charge flows from higher potential to lower potential, therefore $V_A > V_B > V_C > V_D$.

$$\text{For the first capacitor, } V_1 = V_A - V_B = \frac{Q}{C_1} \quad \dots(i)$$

$$\text{For the second capacitor, } V_2 = V_B - V_C = \frac{Q}{C_2} \quad \dots(ii)$$

$$\text{For the third capacitor, } V_3 = V_C - V_D = \frac{Q}{C_3} \quad \dots(iii)$$

Adding (i), (ii) and (iii), we get

$$V_1 + V_2 + V_3 = V_A - V_D = Q \left[\frac{1}{C_1} + \frac{1}{C_2} + \frac{1}{C_3} \right] \quad \dots(iv)$$

If V be the potential difference between A and D , then

$$V_A - V_D = V$$

\therefore From (iv), we get

$$V = (V_1 + V_2 + V_3) = Q \left[\frac{1}{C_1} + \frac{1}{C_2} + \frac{1}{C_3} \right] \quad \dots(v)$$

If in place of all the three capacitors, only one capacitor is placed between A and D such that on giving it charge Q , the potential difference between its plates become V , then it will be called equivalent capacitor. If its capacitance is C , then

$$V = \frac{Q}{C} \quad \dots(vi)$$

Comparing (v) and (vi), we get

$$\frac{Q}{C} = Q \left[\frac{1}{C_1} + \frac{1}{C_2} + \frac{1}{C_3} \right] \quad \text{or} \quad \frac{1}{C} = \frac{1}{C_1} + \frac{1}{C_2} + \frac{1}{C_3} \quad \dots(viii)$$

Q. 8. Answer the following Questions

(i) If two similar large plates, each of area A having surface charge densities $+\sigma$ and $-\sigma$ are separated by a distance d in air, find the expressions for

(ii) Field at points between the two plates and on outer side of the plates. Specify the direction of the field in each case.

(iii) The potential difference between the plates.

(iv) The capacitance of the capacitor so formed. [CBSE Central 2016]

Ans. (i) Let the two large plates each of area A having surface charge densities $+\sigma$ and $-\sigma$ are separated by a distance d in air. We know that electric field due to plate having charge density σ is

$$E = \frac{\sigma}{2\epsilon_0}$$

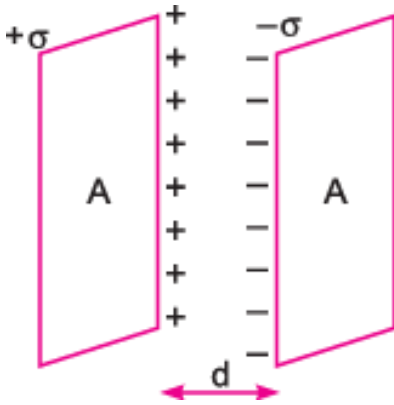

If σ is positive, then electric field will be outward and if σ is negative, then electric field will be inward.

Q. 9. Answer the following questions.

(i) Compare the individual dipole moment and the specimen dipole moment for H_2O molecule and O_2 molecule when placed in

(a) Absence of external electric field

(b) Presence of external electric field. Justify your answer.

(ii) Given two parallel conducting plates of area A and charge densities $+\sigma$ and $-\sigma$. A dielectric slab of constant K and a conducting slab of thickness d each are inserted in between them as shown.

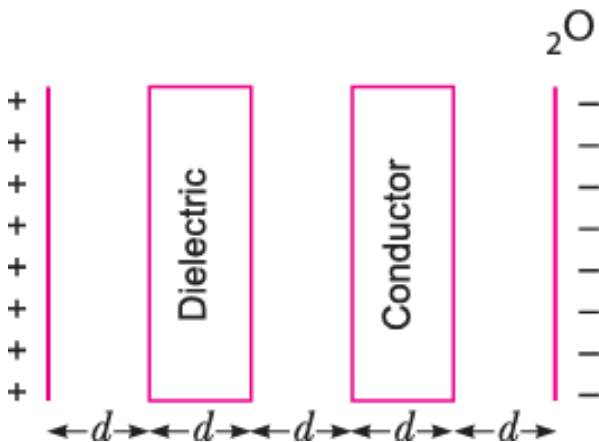

(a) Find the potential difference between the plates.

(b) Plot E versus x graph, taking x = 0 at positive plate and x = 5d at negative plate.

[CBSE Sample Paper 2016]

Ans. (i)

	Non-Polar (O_2)	Polar (H_2O)
(a) Absence of electric field		
Individual	No dipole moment exists	Dipole moment exists
Specimen	No dipole moment exists	Dipole are randomly oriented. Net $P = 0$
(b) Presence of electric field		
Individual	Dipole moment exists (molecules become polarised)	Torque acts on the molecules to align them parallel to \vec{E}
Specimen	Dipole moment exists	Net dipole moment exists parallel to dipole moment exists \vec{E}

(ii) (a) The potential difference between the plates is given by

(b) E versus x graph

